

HANSA FLEX



Hydraulic components



Hose Replacement Service – 24h hour rapid response

Our 280 service vans from the hydraulic emergency service are always just a call away. Whether on the construction site, during the harvest or in industrial applications: in case of a machine failure the job is carried out on site – and around the clock.

Tel. 24/7: 0800 77 12345 (Int. +49 421 9897 7690)



Industrial Service – maintain and optimise

Your machines must be running, around the clock. Preventative maintenance of the HANSA-FLEX Industrial Services helps you to save money and guarantees maximum machine uptime. We will advise you from the selection of the right hydraulic components to the optimisation of your plant and machinery.

www.hansa-flex.com/en/industrial_service



Power Unit Construction – engineering from the specialist

Units are the heart of any hydraulic system. In order to produce a state of the art power unit a high degree of engineering skill is required. The HANSA-FLEX power unit construction offers all services as a single source: from planning, design to installation and commissioning at the customer site.

www.hansa-flex.com/en/unit_manufacture



Online Shop – 24/7 convenient shopping

In our online shop you will find the same variety and quality of products that our customers have been used to for over 50 years: from hydraulic hoses and hose fittings to couplings, ball valves and cylinders – “everything from a single source.”

www.hansa-flex.com/en/shop



X-CODE – hose management

Our customer portal My.HANSA-FLEX offers the perfect solution for preventative maintenance. Users can see the technical data of a hose line at a glance: Manufacturing date, period of use, proposed replacement date, as well as machine and location. Thus, inspection and maintenance intervals can be planned well ahead.

www.hansa-flex.com/en/hose_line_management







HANSA-FLEX – always close to our customers

Through our tight-knit network of branches we are always close to our customers. At each of our 400 locations we offer the complete range of hydraulics: from the standard replacement of a hose line to powerful hydraulic cylinders – personal, fast and reliable.

www.hansa-flex.com/en/subsidiaries

Hydraulic components



























	Technical Information Page 6	T
	Hydraulic components Page 42	1
	Filtration Page 406	2
	Measuring equipment Page 456	3
	Subject Index / Index Page 468	I

We reserve the right to amend the information contained in this catalogue without notice. The information contained in this catalogue is based on many years of experience; however, the technical information shall not be binding on us. Because technical problems are always specific to the case in question, we are available to provide you with advice at any time.

The information and illustrations in this catalogue are provided solely for the purpose of describing the products. They shall not be interpreted as guaranteed characteristics in the legal sense. Despite the most careful checking, we cannot exclude the possibility of mistakes in the catalogue and we accept no liability for the information it contains.

All rights reserved by HANSA-FLEX AG. Reproduction is permitted only with our written permission. The publication of this catalogue supersedes the information in previous editions.

1. Hydraulic components

Pumps		 CETOP sandwich body valves NG10 Page 211	
 Hand pumps Page 44	 CETOP sandwich body valves NG16 Page 223	 CETOP sandwich body valves NG25 Page 226	
 Gear pumps Page 49	 Connector sub-bases for CETOP directional control valves Page 229	 Plate mounting valves Cetop Page 239	
 Axial piston pumps Page 71	 SAE flange connection valves Page 245	 Proportional valves CETOP Page 247	
 Vane pumps Page 74	 Rotary reversing valves Page 260	 Solenoid-operated directional control valves for fitting into pipes Page 264	
Flow divider		 Monobloc manual directional control valves Page 266	
 Gear flow divider Page 75	 Pressure gauge isolation valves Page 276	 Valve accessories Page 277	
Hydraulic motors		Pressure accumulators	
 Planetary motors Page 85	 Bladder accumulator Page 291	 Diaphragm accumulator Page 292	 Accessories Page 294
 Accessories Page 94			
Valves			
 Pipeline installation valve Page 98			
 Cartridge valves Page 131			
 Valve housing for cartridge-type screw-in valves Page 145			
 CETOP directional control valves Page 166			
 CETOP sandwich body valves NG6 Page 198			

1. Hydraulic components

Heat exchangers



Oil/air coolers
Page 300



Accessories
Page 302

Tanks



Aluminium hydraulic tanks
Page 303



Steel hydraulic tanks
Page 306



Hydraulic tank accessories
Page 309

Switches and sensors



Pressure switches and pressure sensors
Page 317



Level switch
Page 325



Temperature switches
Page 330

Unit components



Components for hydraulic power units
Page 334

Electric motors



Alternating current / three-phase current
Page 340



DC
Page 350

Cylinders and cylinder components



Standard cylinders with fastening
Page 353



Standard cylinders without fastening
Page 357



Mounting elements
Page 361



Cylinder bases
Page 370



Oil fittings
Page 375



Guide housing
Page 377



Pistons
Page 380



Piston rods
Page 386



Cylinder barrels
Page 388



Accessories
Page 389

High-pressure hydraulics 700 bar



Pumps
Page 390



Electrohydraulic pumps
Page 391



cylinders
Page 392



Presses
Page 397

1. Hydraulic components



Ball valves
Page 398



Valves
Page 398



Pressure gauge
Page 401



Accessories
Page 402

2. Filtration

Filter



Suction filter
Page 408



Return flow filters
Page 409



Spin-on filters
Page 415



Pressure filters
Page 420



Adsorber filters
Page 429



Accessories
Page 437

Oil sample



Fluid sampling sets
Page 439



Individual parts
Page 440

Oil analysis



Oil analysis equipment
Page 443

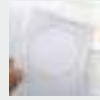

Accessories
Page 447

Filtration



Partial flow filter systems
Page 448



Oil service appliance
Page 450

Oils and bonding agents

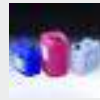

Hydraulic fluids
Page 452



Oil binding agents
Page 454

3. Measuring equipment

Volumetric flow meters



Analogue volume flow meters
Page 458

Digital measurement technology



5-channel gauge
Page 459



2-channel gauge
Page 463

Gear flow meter



Gear flow meter VCA, SD
Page 465

Flow switch



Flow switch BFS
Page 466

T

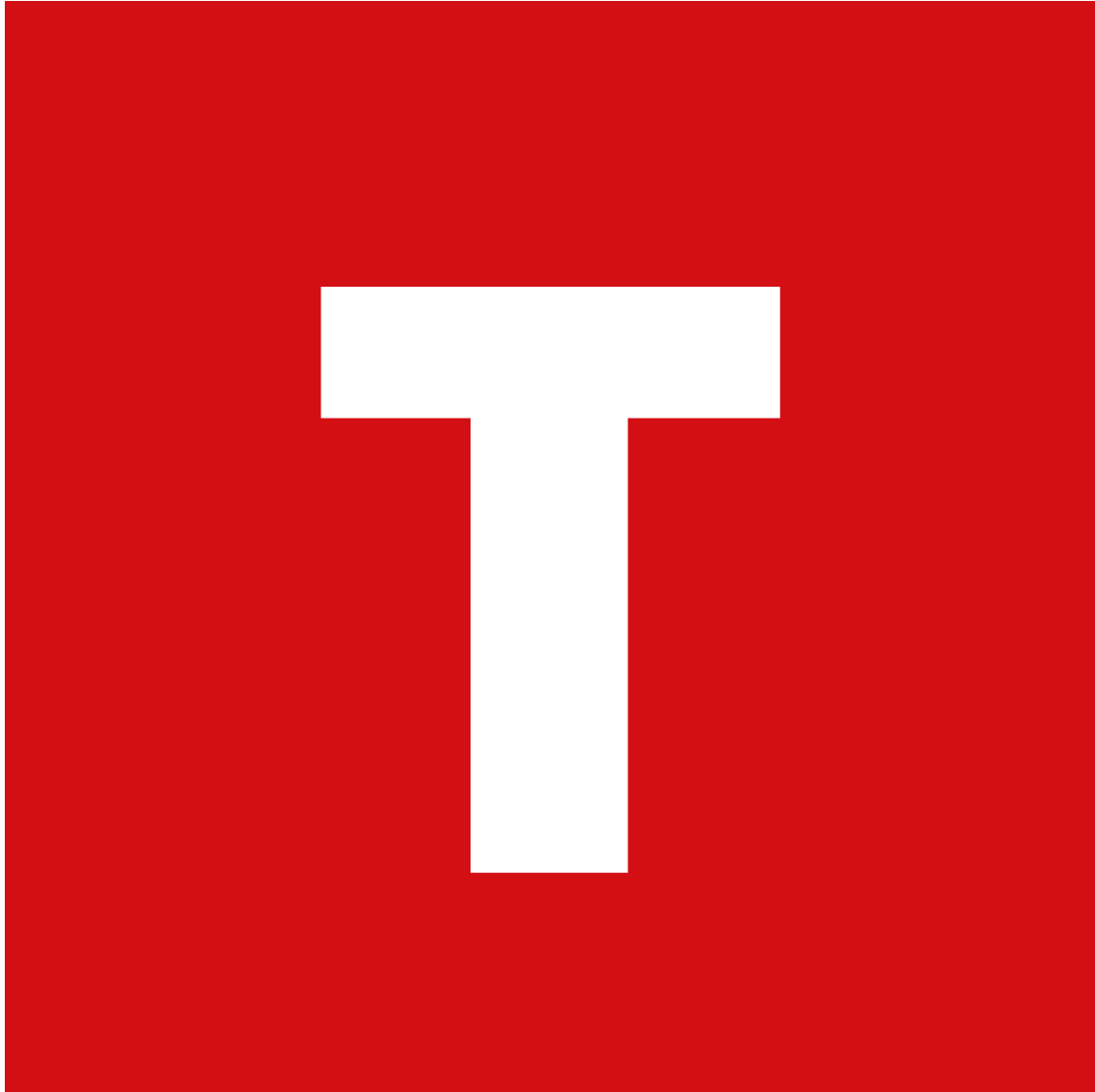

Technical Information

TECHNICAL INFORMATION – HYDRAULIC COMPONENTS

T

TABLE OF CONTENTS

1. GENERAL NOTES
2. COMMISSIONING OF HYDRAULIC SYSTEMS
3. FUNDAMENTAL CALCULATION FORMULAE
4. CIRCUIT SYMBOLS
5. HYDRAULIC VALVES – MOUNTING DIAGRAMS / BORE HOLES
 - 5.1 CETOP mounting diagrams
 - 5.2 Bore holes
6. TECHNICAL INFORMATION FOR HYDRAULIC CYLINDERS
 - 6.1 General
 - 6.2 Technical properties
 - 6.3 Installation
 - 6.4 Commissioning
 - 6.5 Notes on welding on fasteners and colour scheme
 - 6.6 Seals, maintenance, care
 - 6.7 Tables for cylinders
7. SAFETY PRECAUTIONS FOR WORKING WITH 700 BAR EQUIPMENT
8. FILTRATION
 - 8.1 Principles
 - 8.2 Causes of oil contamination
 - 8.2.1 Solid particles (hard or soft)
 - 8.2.2 Free water in the system
 - 8.2.3 Undissolved air in the hydraulic fluid
 - 8.2.4 Oil ageing
 - 8.3 Classification of oil purity
 - 8.4 Filter mesh size, β value and separation rate
 - 8.5 Adsorber filters
 - 8.5.1 Functional principle
 - 8.5.2 Colour saturation
 - 8.6 Demands on hydraulic fluids and their selection
9. SELECTION TABLE OF MOTOR/PUMP COMBINATIONS FOR GEAR PUMPS
10. INFORMATION ON MACHINERY DIRECTIVE 2006/42/EC REGARDING COMPONENTS AND ASSEMBLIES FROM HANSA-FLEX AG

1. GENERAL NOTES



The potential hazards to man and the environment posed by hydraulic systems is very often underestimated in practice. The wrong choice or improper use of components, hoses, fittings and accessories can compromise the product's functional reliability, causing it to fail and possibly posing a threat of personal injury or material damage. In extreme cases, violently spraying oil, shearing fittings and ruptured lines can even cause fatal injuries. Exceeding of the maximum permissible working pressure must be avoided.

We therefore expressly recommend that the applicable safety guidelines are strictly observed!



The owner of machines also bears a particular responsibility.

He is responsible for:

- Ensuring that all components and parts are used only for their intended purpose
- Scheduled monitoring and systematic inspection by qualified persons
- Identifying and eliminating defects
- Scheduled maintenance and replacement of hoses

This active assumption of responsibility is enshrined in the legal framework. Based on the principles of industrial safety, the equipment and product safety act, the machine and pressure device directive and the ordinance on industrial safety and health, tasks are specified further and set out in procedural regulations for those concerned.

2. COMMISSIONING OF HYDRAULIC SYSTEMS

The proper functioning of hydraulic systems presupposes compliance with the respective commissioning and maintenance instructions. All work on hydraulic systems and the components contained must be carried out in strict observance of the safety regulations. There must be no pressure inside the oil-dynamic circuit, i.e. loads must be lowered, pumps switched off and pressure accumulators relieved.

The maximum loads (pressures, forces, temperatures) given in the product documentation must not be exceeded. Furthermore, the hydraulic system must be protected by a pressure relief valve and soiling must be prevented by the use of appropriate filters.

Installation and commissioning of hydraulic systems or their components may only be carried out by suitably qualified personnel. This applies in particular to the connection and commissioning of all electrical assemblies, such as electric motors and electrically actuated components. Operating voltages and the direction of rotation of the electric motor (with DC motors also the polarity) must be strictly observed.

Hydraulic systems with electronic controllers are subject to special commissioning conditions. Pressures and speeds of the pump(s) must first be set to a low value in order to avoid damage caused by faults in the circuitry (electrical or hydraulic). Only when you have ensured that the switching sequences are correct, the consumers are correctly controlled and limits are properly monitored by limit switches, etc. can pressure and delivery rates be increased to the required values.

Hydraulic systems and components may only be employed for their respective intended use. With pipe and hose installations, all lines must be flushed and welded pipes must be inspected and pickled, if necessary. Only approved screws fittings and seal systems may be used for sealing.

The hydraulic systems must be filled with the hydraulic fluids intended for their operation. The components in this catalogue are designed for use with mineral oils to DIN 51524 Part 2 HLP (viscosity 32 – 68 mm²/s at 40°C). Use of other hydraulic fluids (e.g. rapidly biodegradable oils, water/glycol mixtures, etc.) is possible only after consultation with us.

3. FUNDAMENTAL CALCULATION FORMULAE

T

Formula lexicon → Hydraulic pump		
Displacement	$Q_{\text{eff}} = \frac{V \cdot n \cdot \eta_{\text{vol}}}{1000} \left[\frac{\text{l}}{\text{min}} \right]$	Q_{eff} = Effective displacement of hydraulic pump [l/min] V = Geometric displacement [cm ³] η_{vol} = Volumetric efficiency n = Drive speed of the pump [rpm] (Standard speeds of electric motors: 2800/1450/1000 rpm)
Delivery rate	$V = \frac{Q_{\text{eff}} \cdot 1000}{n \cdot \eta_{\text{vol}}} \left[\text{cm}^3 / \text{U} \right]$	V = Geometric displacement [cm ³] Q_{eff} = Effective displacement of hydraulic pump [l/min] η_{vol} = Volumetric efficiency n = Drive speed of the pump [rpm] (Standard speeds of electric motors: 2800/1450/1000 rpm)
Drive power	$P_{\text{An}} = \frac{p \cdot Q_{\text{eff}}}{600 \cdot \eta_{\text{ges}}} \left[\text{kW} \right]$	P_{An} = Required drive power of the pump [kW] P = Working pressure [bar]; [daN/cm ²] Q_{eff} = Effective displacement of a hydraulic pump [l/min] η_{tot} = Overall efficiency (0.8 – 0.85)
Overall efficiency	$\eta_{\text{ges}} = \eta_{\text{mech}} \cdot \eta_{\text{vol}}$	η_{tot} = Overall efficiency (0.8 – 0.85) η_{mech} = Mechanical efficiency (0.9 – 0.95) η_{vol} = Volumetric efficiency (0.9 – 0.95)
Drive torque	$M_{\text{in}} = \frac{\Delta p \cdot V \cdot 1,59}{100 \cdot \eta_{\text{mech}}} \left[\text{daNm} \right]$	M_{in} = Drive torque Δp = Pressure difference between inlet and outlet port of pump [bar] or [daN/cm ²] V = Geometric displacement [cm ³] η_{mech} = Mechanical efficiency (0.9 – 0.95) $1,59 = \frac{10}{\pi}$

Formula lexicon → Hydraulic motor		
Displacement	$Q = \frac{V \cdot n}{1000 \cdot \eta_{\text{vol}}} \left[\frac{\text{l}}{\text{min}} \right]$	Q = Displacement flow of hydraulic motor [l/min] V = Geometric displacement [cm ³] η_{vol} = Volumetric efficiency n = Output speed of the hydraulic motor [rpm]
Drive speed	$n = \frac{Q \cdot \eta_{\text{vol}} \cdot 1000}{V} \left[\text{min}^{-1} \right]$	n = Output speed of the hydraulic motor [rpm] Q = Displacement flow of hydraulic motor [l/min] V = Geometric displacement [cm ³] η_{vol} = Volumetric efficiency
Drive torque	$M_{\text{ab}} = \frac{\Delta p \cdot V \cdot \eta_{\text{mech}}}{2\pi \cdot 100} \left[\text{daNm} \right]$	M_{ab} = Output torque Δp = Pressure difference between inlet and outlet port of motor [bar] or [daN/cm ²] V = Geometric displacement [cm ³] η_{mech} = Mechanical efficiency (0.9 – 0.95)
	$M_{\text{ab}} = \frac{1,59 \cdot V \cdot \Delta p \cdot \eta_{\text{mech}}}{1000} \left[\text{daNm} \right]$	M_{ab} = Output torque Δp = Pressure difference between inlet and outlet port of motor [bar] or [daN/cm ²] V = Geometric displacement [cm ³] η_{mech} = Mechanical efficiency (0.9 – 0.95)
Drive power	$P_{\text{ab}} = \frac{\Delta p \cdot Q \cdot \eta_{\text{ges}}}{600} \left[\text{kW} \right]$	P_{ab} = Drive power of hydraulic motor [kW] Δp = Pressure difference between inlet and outlet port of motor [bar] or [daN/cm ²] Q = Displacement flow of hydraulic motor [l/min] η_{tot} = Overall efficiency (0.8 – 0.85)



Formula lexicon → Hydraulic cylinders – geometric dimensions

Piston area	$A_K = \frac{\pi \cdot d_K^2}{4 \cdot 100} \text{ [cm}^2\text{]}$	A_K = Piston area of the hydraulic cylinder [cm ²] d_K = Piston diameter of the hydraulic cylinder [mm] π = pi ~ 3,14
Piston rod area	$A_S = \frac{d_S^2 \cdot 0,785}{100} \text{ [cm}^2\text{]}$	A_S = Piston rod area of the hydraulic cylinder [cm ²] d_S = Piston rod diameter of the hydraulic cylinder [mm] $0.785 = \frac{\pi}{4}$
Piston ring area	$A_R = \frac{(d_K^2 - d_S^2) \cdot 0,785}{100} \text{ [cm}^2\text{]}$	A_R = Piston ring area of the hydraulic cylinder [cm ²] d_K = Piston diameter of the hydraulic cylinder [mm] d_S = Piston rod diameter of the hydraulic cylinder [mm]

Formula lexicon → Hydraulic cylinders – forces



Force (general)	$F = p \cdot A \text{ [daN]}$	F = Force [daN] p = Working pressure [bar] or [daN/cm ²] A = Effective area [cm ²]
Pressure (general)	$p_{th} = \frac{F}{A} \text{ [daN/cm}^2\text{]}$	p_{th} = Theoretical pressure without allowance for any frictional losses [daN/cm ²] F = Force [daN] A = Effective area [cm ²]
Effective compressive force FD	$F_{D,eff} = \frac{p \cdot d_K^2 \cdot 0,785 \cdot \eta}{10.000} \text{ [kN]}$	$F_{D,eff}$ = Effective compressive force of hydraulic cylinder [kN] p = Working pressure [bar] or [daN/cm ²] d_K = Piston diameter of the hydraulic cylinder [mm] η = Extending efficiency
Effective tensile force FZ	$F_{Z,eff} = \frac{p \cdot (d_K^2 - d_S^2) \cdot 0,785 \cdot \eta}{10.000} \text{ [kN]}$	$F_{Z,eff}$ = Effective tensile force of hydraulic cylinder [kN] p = Working pressure [bar] or [daN/cm ²] d_K = Piston diameter of the hydraulic cylinder [mm] d_S = Piston rod diameter of the hydraulic cylinder [mm] η = Retraction efficiency
Effective differential force FS	$F_{S,eff} = \frac{p \cdot d_S^2 \cdot 0,785 \cdot \eta}{10.000} \text{ [kN]}$	$F_{S,eff}$ = Effective differential force of hydraulic cylinder [kN] p = Working pressure [bar] or [daN/cm ²] d_S = Piston rod diameter of the hydraulic cylinder [mm] η = Extending efficiency

Efficiency η of hydraulic cylinders: Extend 95% (0.95), retract 92% (0.92)

Formula lexicon → Hydraulic cylinders – speeds and stroke times

Piston speed	$v = \frac{s}{t \cdot 1.000} \text{ [m/s]}$	v = Stroke speed [m/s] s = Cylinder stroke [mm] t = Extension or retraction time over complete stroke [s]
Piston speed	$v = \frac{Q}{A \cdot 6} \text{ [m/s]}$	v = Stroke speed [m/s] Q = Inlet volumetric flow at hydraulic cylinder [l/min] A = Effective area [cm ²]

Formula lexicon → Hydraulic cylinders – speeds and stroke times

<p>Required (theoretical) displacement</p>	$Q_{th} = A \cdot v \cdot 60 \left[\frac{l}{min} \right]$ $Q_{th} = \frac{V}{t} \cdot 60 \left[\frac{l}{min} \right]$	<p>Q_{th} = Required (theoretical) displacement of the hydraulic pump without leakage losses [l/min] A = Effective area [cm²] v = Stroke speed [m/s]</p> <p>Q_{th} = Required (theoretical) displacement of the hydraulic pump without leakage losses [l/min] V = Effective volume [l] or [dm³] t = Extension or retraction time over complete stroke [s]</p>
<p>Required volumetric flow for "Extend"</p>	$Q_{ex} = \frac{0,785 \cdot d_K^2 \cdot s \cdot 6}{t \cdot 100.000} \left[\frac{l}{min} \right]$	<p>Q_{th} = Required (theoretical) displacement of the hydraulic pump without leakage losses [l/min] d_K = Piston diameter of the hydraulic cylinder [mm] s = Cylinder stroke [mm] t = Extension or retraction time over complete stroke [s]</p>
<p>Required volumetric flow for "Retract"</p>	$Q_{re} = \frac{0,785 \cdot (d_K^2 - d_r^2) \cdot s \cdot 6}{t \cdot 100.000} \left[\frac{l}{min} \right]$	<p>Q_{th} = Required (theoretical) displacement of the hydraulic pump without leakage losses [l/min] d_K = Piston diameter of the hydraulic cylinder [mm] s = Cylinder stroke [mm] t = Extension or retraction time over complete stroke [s]</p>
<p>Required (effective) displacement</p>	$Q_{eff} = \frac{Q_{th}}{\eta_{vol}} \left[\frac{l}{min} \right]$	<p>Q_{eff} = Required (effective) displacement of the hydraulic pump [l/min] Q_{th} = Theoretical displacement of the hydraulic pump [l/min] η_{vol} = Volumetric efficiency</p>
<p>Extension or retraction volume</p>	$V = \frac{A \cdot s}{10.000} \left[l \right]$	<p>V = Effective volume [l] or [dm³] A = Effective area [cm²] s = Cylinder stroke [mm]</p>
<p>Stroke time</p>	$t = \frac{A \cdot s \cdot 6}{Q \cdot 1.000} \left[s \right]$	<p>t = Extension or retraction time over complete stroke [s] A = Effective area [cm²] s = Cylinder stroke [mm] Q = Inlet volumetric flow at hydraulic cylinder [l/min]</p>

Formula lexicon → Pressure losses in straight pipelines







<p>Pressure loss</p>	$\Delta p = \lambda \cdot \frac{l \cdot \rho \cdot \omega^2 \cdot 5}{d} \left[bar \right]$	<p>Δp = Pressure loss in straight pipelines (laminar or turbulent flow) [bar] λ = Pipe friction coefficient l = Line length in [m] ρ = Density (~0.89) [kg/dm³] ω = Flow velocity [m/s] d = Inside diameter of the line [mm]</p>
<p>Pipe coefficient of friction for laminar flow</p>	$\lambda_{lam} = \frac{64}{Re}$	<p>λ_{lam} = Pipe coefficient of friction for laminar flow Re = Reynolds number</p>
<p>Pipe coefficient of friction for turbulent flow</p>	$\lambda_{turb} = \frac{0,316}{\sqrt{Re}}$	<p>λ_{turb} = Pipe coefficient of friction for turbulent flow Re = Reynolds number</p>

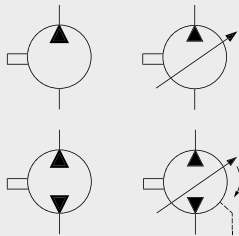
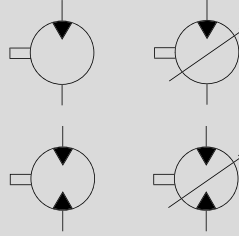
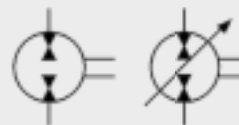
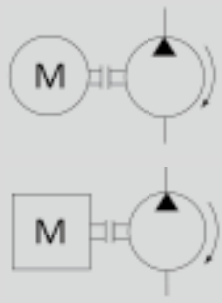

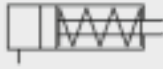

Formula lexicon → Flow velocities in pipelines		
Reynolds number	$Re = \frac{\omega \cdot d}{\nu} \cdot 1000$ $Re = 21232 \frac{Q_{eff}}{d \cdot \nu}$	Re = Reynolds number ω = Flow velocity [m/s] d = Inside diameter of the line [mm] ν = Kinematic viscosity of the liquid [cSt] or [mm ² /s]
Flow velocity	$\omega = \frac{Q_{eff}}{d^2} \cdot 21,232 \left[\frac{m}{s} \right]$	ω = Flow velocity [m/s] Q _{eff} = Fluid flow rate in the line [l/min] d = Inside diameter of the line [mm]
Determination of the pipe inside diameter in pressure lines	$d = \sqrt{\frac{Q_{eff}}{\omega} \cdot 21,232} \text{ [mm]}$	d = Inside diameter of the line [mm] Q _{eff} = Fluid flow rate in the line [l/min] ω = Flow velocity [m/s]

4. CIRCUIT SYMBOLS

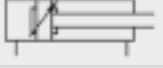
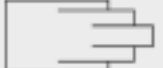
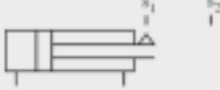
Standardised circuit symbols are required for the representation of hydraulic circuit diagrams. In Germany, these follow the recommendations of ISO 1219 (June 2012). A selection of the most important symbols is shown below:

Designation	Explanation	Symbol
Pumps <ul style="list-style-type: none"> • with one flow direction • with two flow directions (reversible) 	Conversion of mechanical into hydraulic energy	Displacement volume constant variable 
Hydraulic motors <ul style="list-style-type: none"> • with one flow direction • with two flow directions (reversible) 	Conversion of hydraulic energy into mechanical energy with rotational movement	constant variable 
Pump/motor	Units that function both as pumps and as hydraulic motors	constant variable 
Pump drive	with electric motor with internal combustion engine	

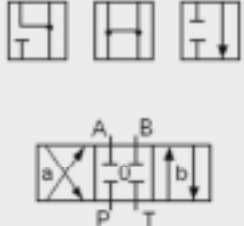
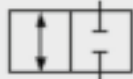
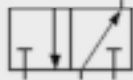
Designation	Explanation	Symbol
Hydrostatic gearboxes	Torque converter, consisting of variable displacement pump and hydraulic motor	
Swivel motor	Rotation angle < 360°	
Cylinders	Conversion of hydraulic energy into mechanical energy with linear movement	
• Single-acting		
• Single-acting with spring return		
• Double-acting differential cylinder		
• Double-acting cylinder with piston rod on both sides		
• Cylinder with end position cushioning		
• Cylinder with adjustable cushioning, on both sides		
• Telescopic cylinder		
• Cylinder with limit switches		

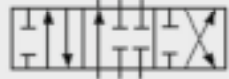





Designation	Explanation	Symbol
<p>Directional control valves</p> <p>Valves that serve to open and shut off different flow paths. Directional control valves are essentially characterised by</p> <ul style="list-style-type: none"> The number of switching positions; represented by a corresponding number of squares, identified by 0, a, b (*) 		
	<ul style="list-style-type: none"> The number of ports and connections within the switching positions; represented by lines and arrows 	
<p>Identification of the ports with letters (in the home position 0)*</p> <p>P... Pump, pressure T... Tank, return line A, B... Consumer X, Y, Z... Control ports L... Leak oil</p> <p>Designation, e.g.: 4/3-way valve 3 → Number of switching positions 4 → Number of ports</p>		
<ul style="list-style-type: none"> 2/2-way valve 		
<ul style="list-style-type: none"> 3/2-way valve 		
<ul style="list-style-type: none"> 4/3-way valve (pressureless circulation) 		
<ul style="list-style-type: none"> 6/3-way valve 		

Designation	Explanation	Symbol
Methods of actuation for directional control valves a) Direct acting	Installation in the respective switching position	Version ISO 1219-1
<ul style="list-style-type: none"> • Hand lever, with latching 		
<ul style="list-style-type: none"> • Pedal 		
<ul style="list-style-type: none"> • Tappet 		
<ul style="list-style-type: none"> • Roller 		
<ul style="list-style-type: none"> • Spring return 		
<ul style="list-style-type: none"> • Spring centering 		
<ul style="list-style-type: none"> • Electromagnetic actuation 	Example: On one side with spring return Example: On two sides with spring return	
<ul style="list-style-type: none"> • Hydraulic actuation 		
<ul style="list-style-type: none"> • Pneumatic actuation 		
b) Pilot-controlled	Larger directional control valves are actuated hydraulically via a pilot valve. This pilot valve is in turn controlled electrically or pneumatically.	
<ul style="list-style-type: none"> • Hydraulically actuated, electromagnetically controlled 		

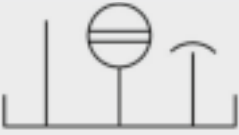
Designation	Explanation	Symbol
Throttling directional control valves Directional control valves with stepless transition between the individual switching positions with variable throttling effect. Represented by parallel lines over the length of the symbol.		
<ul style="list-style-type: none"> Sensor valve with roller tapped, acting against a return spring 		
<ul style="list-style-type: none"> Electrohydraulic proportional directional control valve 		
<ul style="list-style-type: none"> Electrohydraulic control valve with position control of the valve spool 		
Pressure valves Valves which influence the pressure. Represented by a single square with an arrow, the throttling cross-section is infinitely variable.		
<ul style="list-style-type: none"> Pressure-relief valve; directly controlled 	Normally closed; opens when the set inlet pressure is reached	
<ul style="list-style-type: none"> Pressure-relief valve; pilot-controlled 	Control oil discharge normally internal	
<ul style="list-style-type: none"> Pressure reduction valve (pressure control valve); directly controlled 	Normally open; closes when the set outlet pressure is reached; external leak oil port	
<ul style="list-style-type: none"> Pressure reduction valve; pilot-controlled 	Control oil discharge only external	
<ul style="list-style-type: none"> 3-way pressure reduction valve; directly controlled 	On relief of the consumer via the third port	
<ul style="list-style-type: none"> Externally controlled sequence valve; pilot-controlled 	Switches a hydraulic connection when the set pressure is reached	
<ul style="list-style-type: none"> Pressure switch 	Switches an electrical connection when a certain pressure is reached	

Designation	Explanation	Symbol
Flow control valves Valves which influence the volumetric flow. Represented by a constriction of the line cross-section.		
• Orifice	Short throttled length	
• Throttle (fixed or variable)	Volumetric flow dependent on the pressure difference	
• Throttle check valve		
• Flow control valve	Volumetric flow independently of the pressure difference or load	
	With bypass non-return valve	
• 3-way flow control valve	Excess flow is diverted via the third port (irrespective of viscosity, orifice)	
• Flow divider	Split in a fixed ratio	

Designation	Explanation	Symbol
Check valves Valves which seal off pressure and flow in one direction by means of a valve seat.		
• Check valve	With or without closing spring	
• Closed check valve	Opens the closed direction when pressure is applied to the control port	
• Magnetically actuated seat valve	Opens the closed direction when electricity is supplied to the solenoid	
• Shuttle valve	“OR” function	
Lines and connections		
• Lines	Main lines Control and leak oil lines Flexible hoses	
• Line connection		
• Crossed line without connection		
• Venting		
• Quick release coupling		
• Rotary connection		

Designation	Explanation	Symbol
Oil treatment, measuring instruments, miscellaneous		
• Tank with lines, oil level indicator and vent		
• Hydraulic accumulators		
• Filters		
• Coolers		
• Heater		
• Pressure gauge		
• Volume flowmeter		

5. HYDRAULIC VALVES – MOUNTING DIAGRAMS / BORE HOLES

5.1 CETOP MOUNTING DIAGRAMS

T

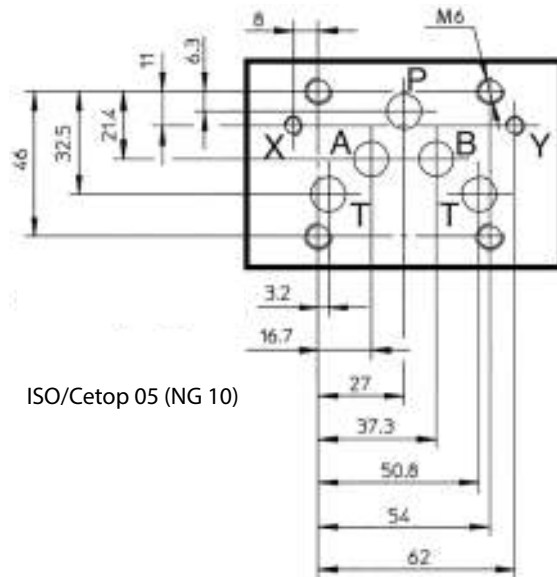
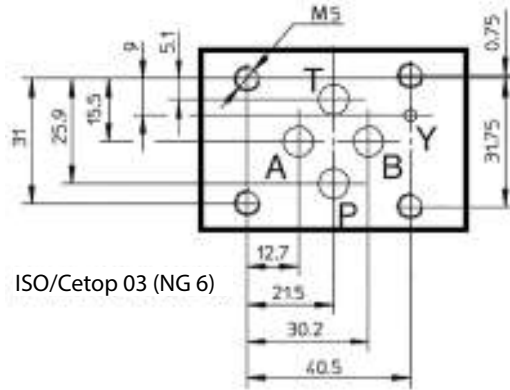

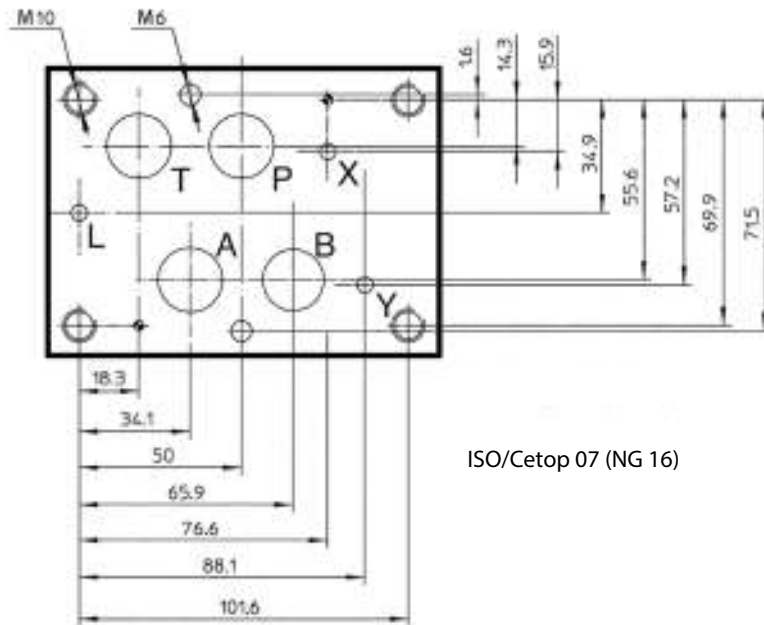

ISO/Cetop 07 (NG 16)

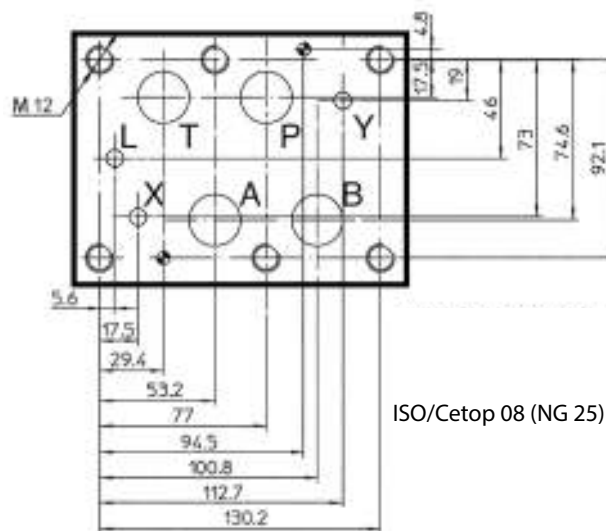

ISO/Cetop 08 (NG 25)



Cavity Type C1030

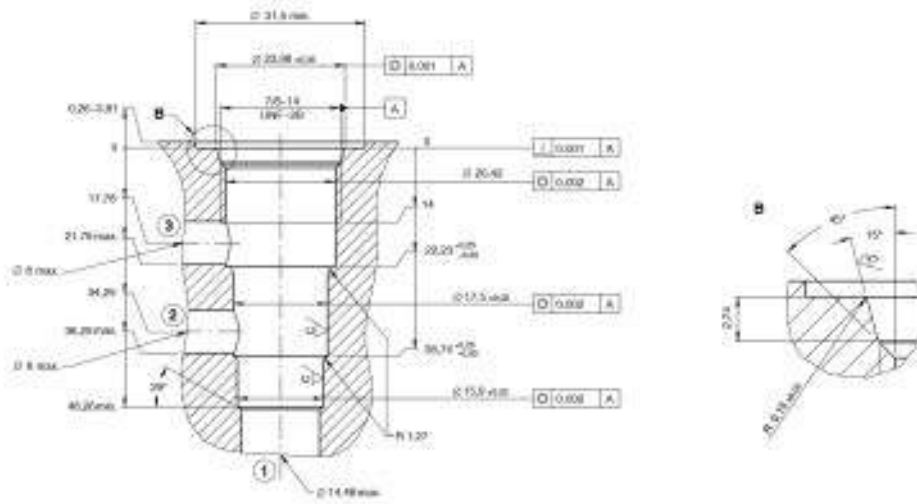

Cavity Type C1020

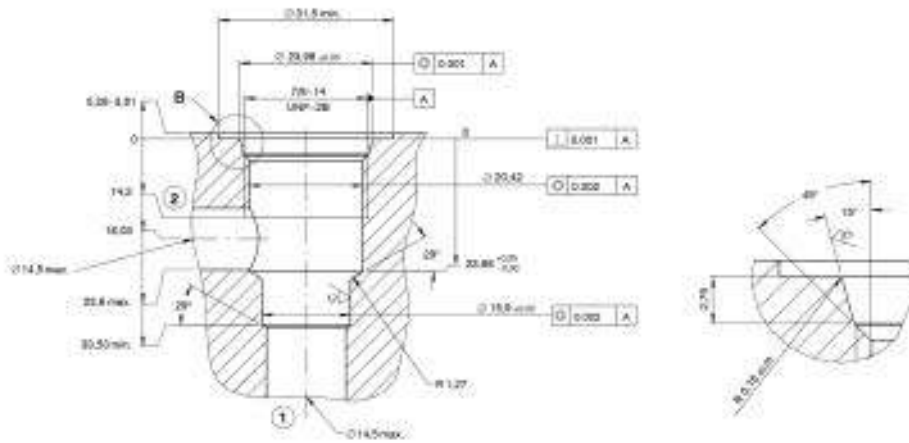

6. TECHNICAL INFORMATION FOR HYDRAULIC CYLINDERS

6.1 GENERAL

Please observe the provisions of EN ISO 4413 (2011) "Hydraulic fluid power - General rules and safety requirements for systems and their components" as well as specifications and safety requirements based on statutory regulations when selecting, installing and operating cylinders. The maximum loads (pressures, forces, temperatures) given in the product documentation must not be exceeded.

The pressure is boosted by throttling the oil draining from the piston rod side. Further pressure can be built up by a load pulling on the piston rod, and this combination can easily lead to failure of the cylinder.

Loosening of a consumer port on the cylinder can result in a free fall or uncontrolled lowering of loads. Unauthorised removal of the cylinders or their components can lead to a voiding of warranty claims.

The chrome coating of the piston rod and external components on the cylinder must be protected during transport.

Hydraulic cylinders must be stored dry and at the most constant possible ambient temperature in order to avoid the formation of condensation. The storage locations must be free of vapours and corrosive substances. The oil ports must be sealed with protective caps.

If hydraulic cylinders are not required for longer than 2 months, they must be stored upright with fully retracted piston rod. There is otherwise a risk of permanent deformation of the seals. The cylinders must be filled with a suitable hydraulic fluid in order to avoid corrosion.



T

6.2 TECHNICAL CHARACTERISTICS

Standard cylinders up to 200 bar

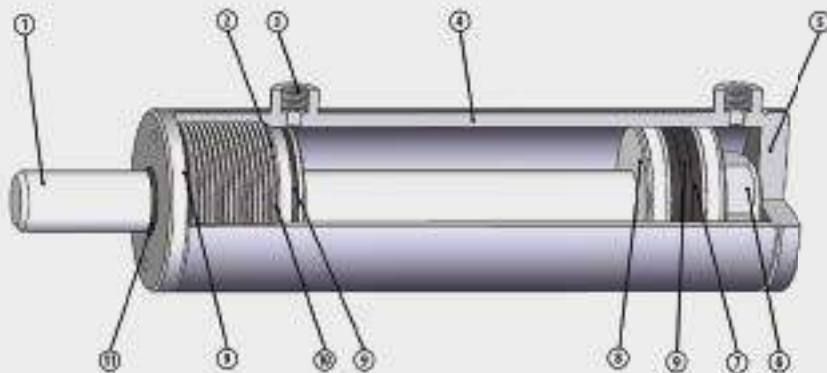

1 Piston rod	steel 20MnV6 Chrome 25 µm ± 5 (120 hour salt spray test to ISO 3768 - evaluation in accordance with ISO 4540 Class 9)
2 Piston rod guide	hydraulic casting UNI 5007 G25
3 Oil ports	steel 9SMn28
4 Polished cylinder barrel	St 52.3 DIN 2393-ISO H9
5 Cylinder base	FE 510-A105
6 Nut	steel 8UNI EN20898/2
7 Seal TPM	NBR
8 Piston	steel 9SMn28
9 Seal OR	NBR Fluorosil Viton
10 Seal TSE-TTS-TTI/L	NBR + fabric / polyurethane
11 Seal GHM-GHK	NBR / polyurethane
Piston speed referred to standard seals	max. 25 m/min - 0.42 m/sec
Piston speed in the end positions	max. 6 m/min - 0.10 m/sec
Temperature range	-25°C to +80°C
Max. working pressure (to DIN EN 982)	200 bar
Test pressure (to DIN EN 982)	240 bar
Medium	HLP fluids

6.3 INSTALLATION

Hydraulic cylinders must be installed such that lateral loads are avoided during operation. The installation position can be freely selected as long as the buckling safety is observed. The stroke end of the hydraulic cylinders must not be used as an end stop.

With bored piston rods (double-acting cylinders), attention must be paid to the pivot pin (shear forces).

Where driving loads are involved, external end stops and load-holding or counterbalancing valves must be installed.

When connecting to the pressure supply, pay attention to the correct identification of the connecting lines (see marks, if necessary). Furthermore, the admissible pressure values for screw fittings, pipes and hose lines must be observed.

When using double-acting cylinders as single-acting cylinders, the second oil port must be connected to the hydraulic oil tank so that oil can be drawn in.

The piston rod should be protected against foreseeable damage and corrosion. Pipes, screw fittings, etc. must be cleaned of dirt, chips, scale, etc. before installation and then securely fitted.

Before connecting the hydraulic cylinder to the drive unit, flush the aggregate and the supply lines. The consumer lines must be connected together in order to do this. The flushing process is intended to remove dirt and air from the consumer lines.

Hydraulic cylinders must be vented before commissioning. To do this, slightly loosen the oil ports or the vent plugs on the cylinders and place a suitable vessel underneath to collect the oil. Then move the cylinder pressure-free between the two end positions until the oil runs out bubble-free and without foaming. Turn the oil ports to the highest possible position for quicker venting.

6.4 COMMISSIONING

- Check of the complete and proper installation (incl. electrical components such as stroke measuring system, end position switches, etc.)
- Switch on the system in jog mode and check that no hazardous movement occurs, then switch the system to continuous mode
- Allow the system to run for approx. 2–3 minutes pressure-free and check the lines and devices for leaks
- Set operating values (pressure, speed) according to the system documentation

Valves already set by HANSA-FLEX are sealed with lacquer or a lead seal and must not be adjusted without consultation. The correct setting of these valves is safety-relevant.

6.5 NOTES ON WELDING ON FASTENERS AND PAINTING

- The piston rod must be completely extended; on cylinders with stroke <400 mm they must be completely removed before welding (protect seals from heat).
- The piston rod must be protected from weld spatter.
- The ground cable must always be connected to the part to be welded on, never to the piston rod or cylinder barrel.
- Retract the piston rod only when the cylinder has cooled down.
- During painting, the chrome-plated surface of the piston rod and the oil ports must be protected from paint spray mist.
- When drying in a drying cabinet after painting, the temperature must not exceed 100°C.

6.6 SEALS, MAINTENANCE AND CARE

Seals in hydraulic cylinders are wear parts. If the admissible values for external or internal leakage are exceeded, the seals must be replaced. Complete seal kits should always be replaced together.

In general, hydraulic cylinders require no particular maintenance. Where heavy-duty operation is involved, ensure proper lubrication of the bearing points (pivot bearings, swivel bearings, etc.). After commissioning, pay particular attention to leak tightness and functional safety.

The maintenance intervals for the system (oil and filter changes) in the system manufacturer's specifications must be observed.

6.7 TABLES FOR CYLINDERS

Buckling diagram for single and double-acting cylinders (buckling safety factor 3.5)

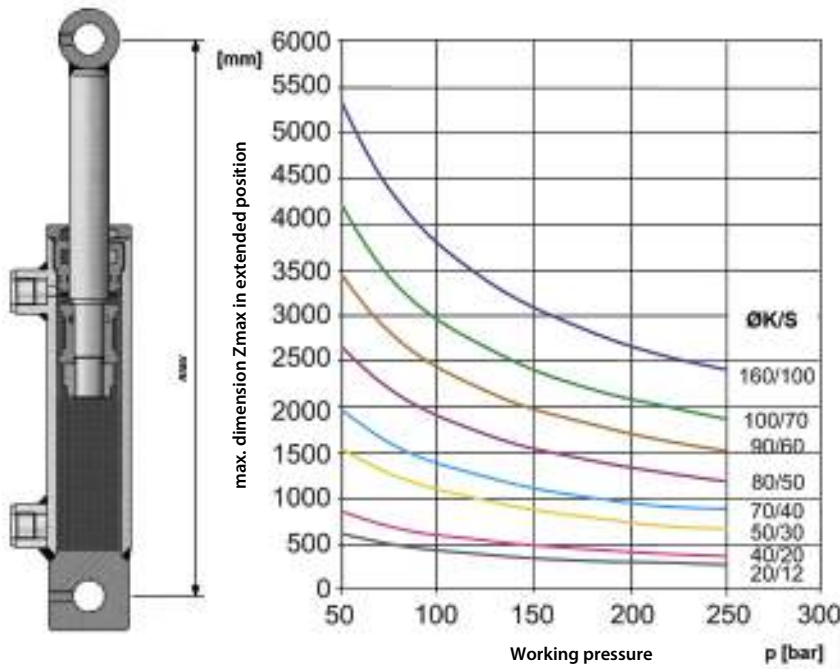

Pressure force diagram for single and double-acting cylinders (efficiency 95%)

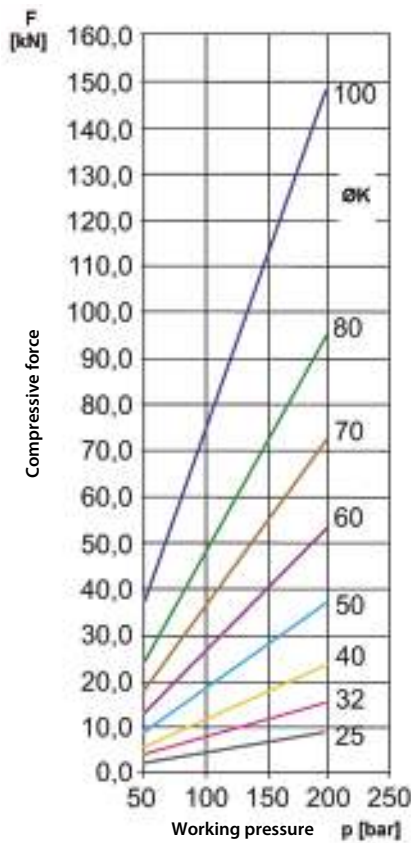

Tensile force diagram for double-acting cylinders (efficiency 92%)

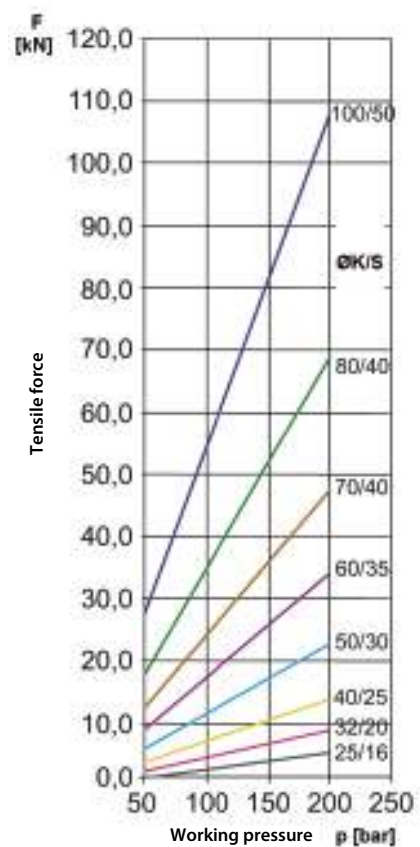

7. SAFETY PRECAUTIONS FOR WORKING WITH 700 BAR EQUIPMENT



- Observe the operating instructions
- Utilise only 80% of the equipment's loading capacity
- Wear protective work clothing
- Use equipment only on a level surface of sufficient load-bearing strength
- Secure raised loads mechanically
- Do not stand or walk under raised loads
- Position the equipment under the middle of the load
- Protect the equipment against heating > 65°C
- Avoid overloading the equipment
- Use a pressure gauge
- Do not actuate hand levers using tools or extensions
- Clean the equipment and pack away properly after use
- Clean quick-couplers before use
- Protect hoses from sharp edges, kinks and other forms of damage

8. FILTRATION

8.1 BASIC PRINCIPLES

75% of all hydraulic systems are heavily contaminated. 80% of all machine failures or hydraulic damage are attributable to oil contamination. Wear and ageing are two reasons why the oil has to be changed at regular intervals.

The time for an oil change depends on the performance of the oil and on the operating and service conditions. This is no guarantee, however, of permanently clean oil, since even fresh oil is often already heavily contaminated on delivery. This results in increased component wear, machine failure and possibly production standstills. Machine standstill times can be minimised by selective and consistent use of filters.

8.2 CAUSES OF OIL CONTAMINATION

8.2.1 SOLID PARTICLES (HARD OR SOFT)

- Due to installation work or when changing parts
- Due to topping up with new (contaminated) hydraulic fluid
- Via the wipers and seals of the cylinders
- Due to a faulty tank seal
- Due to internal abrasion in the components

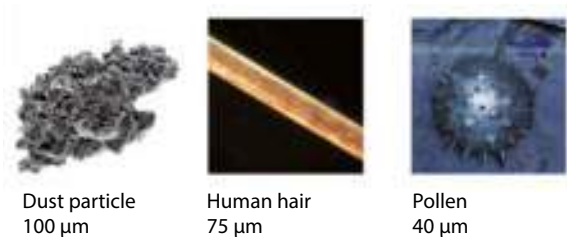

Solid particles can result in mechanical wear to all the components in the hydraulic system. Typical particle sizes in a hydraulic system range from 4 µm to 14 µm (for comparison: Pollen particle 40 µm, human hair 75 µm, dust particle 100 µm).

8.2.2 FREE WATER IN THE SYSTEM

- Due to a faulty tank seal
- Due to cleaning work (e.g. with high-pressure cleaners)
- Via the ambient air (tank breather)
- Condensation
- Leaks in the cooling system

With water droplets with a size of over 2–10 µm, the oil becomes cloudy and the saturation limit of the oil is reached. The water content in the hydraulic oil should not exceed 0.03%. Consequences of water in the hydraulic oil can be: Metal corrosion, oxidation, saponification, gumming, swelling, cavitation, acid formation, increased coefficient of friction with increased wear.

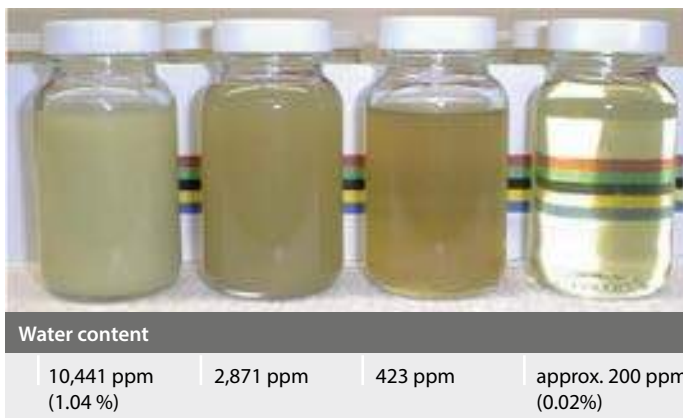

8.2.3 UNDISSOLVED AIR IN THE HYDRAULIC FLUID

- Due to leaks in the system (vacuum)
- Due to installation work
- Oil return to the tank (swirling, air mixing)

If the air is dissolved in the oil, this has no influence on the properties. The air is dissolved in the water in proportion to the pressure (up to approx. 300 bar). Dissolved air is discharged to the saturation limit at low pressure. Due to the differences between discharge rate and solution rate, however, air bubbles remain in the oil even in the event of a renewed increase in pressure.



Undissolved air can lead to serious damage. This is caused e.g. by the micro-diesel effect (spontaneous ignition of an air/gas mixture in the high-pressure range, similar to cavitation). Gas bubbles in the hydraulic system can enter the seal gap and the gap edges of the valves and explode as a result of the compression. These seals are destroyed in a minimum of time and the gap edges of the valves are damaged.

8.2.4 OIL AGEING

- Mixing of different oils
- Excessive operating temperatures due to inadequate cooling
- Poor material compatibility of the oil
- Inadequate oxidation stability of the base oils

8.3 CLASSIFICATION OF OIL PURITY

ISO Standard ISO 4406: 1999 is a preferred method of classifying oil purity (contamination by solid particles). The code consists of a combination of three numerical values. The first figure describes the number of particles larger than 4 µm in one millilitre of test fluid. The second figure stands for the number of particles larger than 6 µm. The third figure stands for the number of particles larger than 14 µm.

ISO 4406:1999 Table of solid contaminants in hydraulic oils		
Number of particles per 1 ml of fluid		CODE
larger than:	up to:	
1,300,000	2,500,000	28
640,000	1,300,000	27
320,000	640,000	26
160,000	320,000	25
80,000	160,000	24
40,000	80,000	23
20,000	40,000	22
10,000	20,000	21
5,000	10,000	20
2,500	5,000	19
1,300	2,500	18
640	1,300	17
320	640	16
80	320	15
40	160	14
20	80	13

In the example the code 22/19/14 means
 20,000 – 40,000 particles > 4 µm
 2,500 – 5,000 particles > 6 µm
 80 – 160 particles > 14 µm

The oil purity is generally determined in accordance with ISO 4406:1999 using a laser particulate counter.

Typically recommended oil purity specifications for hydraulic components

Component	Typical specification						
Servo valve	●	●	●				
Proportional valve		●	●	●			
Variable displacement pumps			●	●	●		
Cartridge valve				●	●	●	
Piston pump				●	●	●	
Vane pump					●	●	●
Pressure relief valve					●	●	●
Solenoid-operated directional control valve					●	●	●
ISO 4406:1999 CODE	14/12/9	15/13/10	16/14/11	17/15/12	18/16/13	19/17/14	20/18/15
Recommended filter mesh size (absolute)	3 μm		6 μm		10 μm		> 10 μm

8.4 FILTER MESH SIZE, β VALUE: AND SEPARATION RATE

Apart from their differentiation by function (e.g. pressure filter, return filter, suction filter), hydraulic filters are also classified according to the filter material and the filter mesh size (μm). Depending on the application, filters with mesh sizes between 3 μm and 250 μm are employed.

Further important parameters for the performance of a filter are the β value and the separation rate.

The β value (ISO 16889) is the measure of the filter separation rate and indicates the ratio of particles upline (Nv) and downline of the filter (Nh).

$$\beta_x = N_v / N_h$$

β₁₀ > 200 therefore means that of 1000 particles with a size of 10 μm, only five particles pass through the filter. 995 particles are retained. Filters with fibreglass media must achieve a β value of min. 200 in order to meet present-day demands on hydraulic filtration.

The separation rate (retention rate) thus has the following direct relationship with the β value:

$$\epsilon = (\beta_x - 1) / \beta_x$$

A value of β₁₀ > 200 thus corresponds to a separation rate of 99.5%.

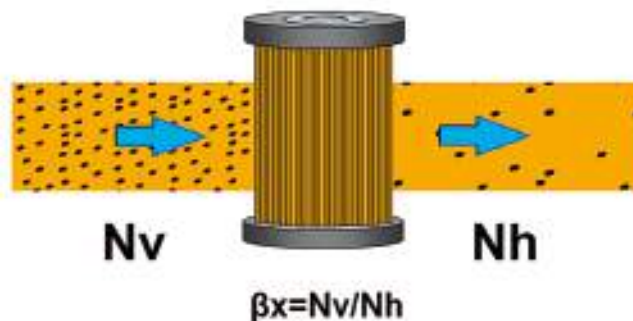

8.5 ADSORBER FILTERS

8.5.1 FUNCTIONAL PRINCIPLE

In numerous applications, e.g. in hydraulic systems or gearboxes, water is one of the main causes of damage and high costs. Water hereby enters the systems as humidity from the ambient air due to temperature fluctuations or active removal of the hydraulic oil. The use of adsorber filters can help to bind the humidity in the intaken air and so reduce the contamination of the hydraulic oil. That means longer service lives, less damage and ultimately lower costs.

On the basis of the thermal process engineering, the adsorption, the water in the air is retained in the pores of the adsorbent (desiccant). There is there no change in volume and only the weight increases. The maximum water adsorption capacity is approx. 35% w/w. During the adsorption process, the intaken air is dried, while the dry waste air allow a cyclic regeneration of the adsorbent. A precondition for a high efficiency is the use of activated charcoal to separate the oil mist and an optional valve system to prevent loading during standstill times.



8.5.2 COLOUR SATURATION



The saturation and the then necessary replacement of the adsorbent is indicated by a change in colour from orange to green. Silica gel (silicon oxide SiO₂) with heavy metal-free pH indicators (organic pigments) is used in the adsorber filters. These are substances whose colour depends on the pH value of the solution.

Silica gel and the pH indicators used are classified as non-hazardous substances according to the legislation of the European Union (EC Directive No. 1272/2008). It is not subject to mandatory labelling according to EC Guidelines (67/548/EEC and 1999/45/EC) and the corresponding national laws. The adsorbents used are therefore not health or environment-endangering substances.

8.6 DEMANDS ON HYDRAULIC FLUIDS AND THEIR SELECTION

The following main characteristics must be observed when selecting the hydraulic fluid:

- Viscosity, viscosity index, viscosity class VG (viscosity at 40°C), pour point

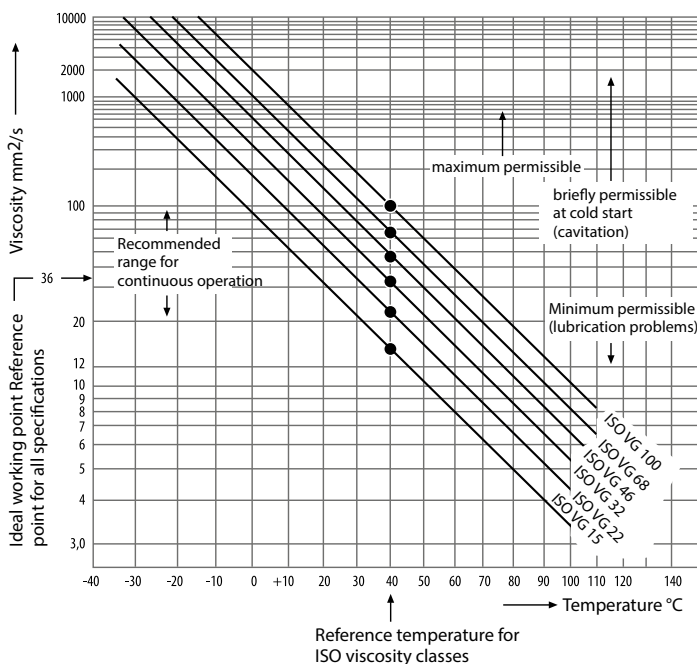

NOTE:
The information given in the catalogue on the individual devices (specifications) is binding

For a given application, the characteristics of the hydraulic fluid have to be reconciled with the operating conditions of the system and its components. A hydraulic fluid has a low viscosity when it is thin-bodied and a high viscosity when it is thick-bodied.

The viscosity changes with the temperature. The viscosity drops with increasing temperature. The viscosity rises with decreasing temperature. Mixing of unsuitable or different hydraulic fluids is not permitted and can lead to the total failure of the hydraulic system.

9. SELECTION TABLE OF MOTOR/PUMP COMBINATIONS FOR GEAR PUMPS

The selection table shows possible combinations of electric motors of sizes 71 to 180 (mounting B3B5) and gear pumps of sizes BG0 to BG3 (European standard) with the corresponding pump mounts and couplings.



For particularly high torques, combinations with steel coupling should be used!

Gear pump size BG 0: Hole pattern 66 / Centering dia. 22.0 / Cylindrical shaft dia. 7.0

Gear pump size BG 1: Hole pattern 71.9 x 52.4 / Centering dia. 25.4 / Conical shaft 1:8

Gear pump size BG 2: Hole pattern 96.2 x 71.5 / Centering dia. 36.5 / Conical shaft 1:8

Gear pump size BG 3: Hole pattern 128 x 98 / Centering dia. 50.8 / Conical shaft 1:8

Electric motor (Article number)	Power (kW)	Gear pump (Master designation from this catalogue)	Size	Pump mounts (Article number)	Coupling (Article number)
HK 71 A4 B35 2-4A	0.25	HK 0P ABBA	BG 0	HK PT RV 160 70 468	HK A1914 714 184 AL
HK 71 B4 B35 2-4A	0.37	HK 0P ABBA	BG 0	HK PT RV 160 70 468	HK A1914 714 184 AL
HK 80 A4 B35 2-4A	0.55	HK 0P ABBA	BG 0	HK PT RV 200 80 468	HK A1919 714 184 AL
HK 80 B4 B35 2-4IE2	0.75	HK 0P ABBA	BG 0	HK PT RV 200 80 468	HK A1919 714 184 AL
HK 71 A4 B35 2-4A	0.25	HK 1P FIIA, HK 1P FBBA	BG 1	HK PT RV 160 80 448 ZFV	HK A1914 N1 AL
HK 71 B4 B35 2-4A	0.37	HK 1P FIIA, HK 1P FBBA	BG 1	HK PT RV 160 80 448 ZFV	HK A1914 N1 AL
HK 80 A4 B35 2-4A	0.55	HK 1P FIIA, HK 1P FBBA	BG 1	HK PT RV 200 80 448	HK A1919 N1 AL
HK 132 M4 B35 4-6IE2	0.75	HK 1P FIIA, HK 1P FBBA	BG 1	HK PT RV 200 80 448	HK A1919 N1 AL
HK 90 S4 B35 2-4IE2	1.10	HK 1P FIIA, HK 1P FBBA	BG 1	HK PT RV 200 90 448	HK A1924 24 N1 AL
HK 90 L4 B35 2-4IE2	1.50	HK 1P FIIA, HK 1P FBBA	BG 1	HK PT RV 200 90 448	HK A1924 24 N1 AL
HK 100 LA4 B35 2-4IE2	2.20	HK 1P FIIA, HK 1P FBBA	BG 1	HK PT RV 250 110 448	HK A2432 28 60 N1 AL
HK 100 LB4 B35 2-4IE2	3.00	HK 1P FIIA, HK 1P FBBA	BG 1	HK PT RV 250 110 448	HK A2432 28 60 N1 AL
HK 112 M4 B35 4-6IE2	4.00	HK 1P FIIA, HK 1P FBBA	BG 1	HK PT RV 250 110 448	HK A2432 28 60 N1 AL
HK 80 A4 B35 2-4A	0.55	HK 2P EOOA/EPOA/EQPA, HK 2P EBBA/ECBA, HK CBTF	BG 2	HK PT RV 200 96 446 ZFV	HK A2419 N2A AL
HK 80 B4 B35 2-4IE2	0.75	HK 2P EOOA/EPOA/EQPA, HK 2P EBBA/ECBA, HK CBTF	BG 2	HK PT RV 200 96 446 ZFV	HK A2419 N2A AL
HK 90 S4 B35 2-4IE2	1.10	HK 2P EOOA/EPOA/EQPA, HK 2P EBBA/ECBA, HK CBTF	BG 2	HK PT RV 200 96 446 ZFV	HK A2424 N2A AL
HK 90 L4 B35 2-4IE2	1.50	HK 2P EOOA/EPOA/EQPA, HK 2P EBBA/ECBA, HK CBTF	BG 2	HK PT RV 200 96 446 ZFV	HK A2424 N2A AL
HK 100 LA4 B35 2-4IE2	2.20	HK 2P EOOA/EPOA/EQPA, HK 2P EBBA/ECBA, HK CBTF	BG 2	HK PT RV 250 110 446	HK A2432 28 N2A AL
HK 100 LB4 B35 2-4IE2	3.00	HK 2P EOOA/EPOA/EQPA, HK 2P EBBA/ECBA, HK CBTF	BG 2	HK PT RV 250 110 446	HK A2432 28 N2A AL
HK 112 M4 B35 4-6IE2	4.00	HK 2P EOOA/EPOA/EQPA, HK 2P EBBA/ECBA, HK CBTF	BG 2	HK PT RV 250 110 446	HK A2432 28 N2A AL
HK 132 SB4 B35 4-6IE2	5.50	HK 2P EOOA/EPOA/EQPA, HK 2P EBBA/ECBA, HK CBTF	BG 2	HK PT RV 300 130 446	HK A2838 38 60 N2A AL
HK 132 M4 B35 4-6IE2	7.50	HK 2P EOOA/EPOA/EQPA, HK 2P EBBA/ECBA, HK CBTF	BG 2	HK PT RV 300 130 446	HK A2838 38 60 N2A AL
HK 132 SB4 B35 4-6IE2	5.50	HK 2P EOOA/EPOA/EQPA, HK 2P EBBA/ECBA, HK CBTF	BG 2	HK PL3000102	HK R28 38 N2A
HK 132 M4 B35 4-6IE2	7.50	HK 2P EOOA/EPOA/EQPA, HK 2P EBBA/ECBA, HK CBTF	BG 2	HK PL3000102	HK R28 38 N2A
HK 160 M4 B35 4-6IE2	11.00	HK 2P EOOA/EPOA/EQPA, HK 2P EBBA/ECBA, HK CBTF	BG 2	HK PT RV 350 173 446	HK A3845 42 N2A AL
HK 160 L4 B35 4-6IE2	15.00	HK 2P EOOA/EPOA/EQPA, HK 2P EBBA/ECBA, HK CBTF	BG 2	HK PT RV 350 173 446	HK A3845 42 N2A AL
HK 160 M4 B35 4-6IE2	11.00	HK 2P EOOA/EPOA/EQPA, HK 2P EBBA/ECBA, HK CBTF	BG 2	HK PL3500105	HK R38 42 N2A
HK 160 L4 B35 4-6IE2	15.00	HK 2P EOOA/EPOA/EQPA, HK 2P EBBA/ECBA, HK CBTF	BG 2	HK PL3500105	HK R38 42 N2A
HK 100 LA4 B35 2-4IE2	2.20	HK X3P ABAA/ACBA, HK CBD1 F5	BG 3	HK PT RV 250 115 465	HK A2432 28 N3 AL
HK 100 LB4 B35 2-4IE2	3.00	HK X3P ABAA/ACBA, HK CBD1 F5	BG 3	HK PT RV 250 115 465	HK A2432 28 N3 AL
HK 112 M4 B35 4-6IE2	4.00	HK X3P ABAA/ACBA, HK CBD1 F5	BG 3	HK PT RV 250 115 465	HK A2432 28 N3 AL
HK 132 SB4 B35 4-6IE2	5.50	HK X3P ABAA/ACBA, HK CBD1 F5	BG 3	HK PT RV 300 144 465	HK A2838 38 60 N3 AL

10. INFORMATION ON MACHINERY DIRECTIVE 2006/42/EC REGARDING COMPONENTS AND ASSEMBLIES FROM HANSA-FLEX AG

T The Machinery Directive 2006/42/EC demands from the machine manufacturer the identification of the necessary safety functions with definition of a safety level for the safety-related control system. Relevant in this sense are only the components used in the safety circuit, such as for the dead-man circuit or safety temperature controller. These safety components are components which are not necessary for the actual function of the machine or which can be replaced by parts that are normally used for the function of the machine. Only then are hydraulic components to be regarded as safety components and have to bear the CE mark. If these special safety components are brought onto the market, the MTBF values (mean time between failures) for calculation of the performance level (PL) are shown in our documentation.

Components and assemblies from the HANSA-FLEX AG product range are generally not subject to this guideline. Where this is not the case, the corresponding documentation is supplied.

Since the Machinery Directive 2006/42/EC came into force, manufacturer's declarations are no longer issued for components and assemblies. For components requiring CE marking, an EC Declaration of Conformity is issued.

Products

Hydraulic hoses



Hose lines in all nominal diameters and for every field of application

Hydraulic steel tubes



Precision tubes conforming to DIN 2391, deliverable as single items or in series

Hose fittings



Comprehensive range of fittings in stock, custom designs at very short notice

Fittings



Many different dimensions and shapes; available in both steel and stainless steel

Couplings



Available immediately from stock; couplings for every conceivable purpose

Metal & PTFE hoses



Special hose lines for solid, liquid and gaseous media

Bellows & expansion joints



Stainless steel and rubber, standard or custom design for your requirements

Industrial hoses



Hoses, fittings and couplings for industrial applications in many sectors

Preformed hoses



Many standard sizes ex warehouse, custom designs for all geometries

Hydraulic cylinders



Many variants available in standard inventory, custom designs at short notice

Hydraulic components



More than 4,500 components available from stock – supply of ready-to-install groups

Power unit manufacture



Innovative solutions in hydraulic drive and control technology

High pressure flanges



Many designs in all standard alloys permanently in stock – up to 6,000 psi and higher

Measuring systems



Extensive range of measuring systems for fluid Technology – analog or digital

Mounting technology



Deliverable materials: polypropylene, polyamide, solid rubber and aluminium

Adapters



Wide range of adapters for optimum flow conditions

Hydraulic seals



More than 8,000 different sealing systems in stock, custom designs available at short notice

Filtration



Filter technology ensures a smooth operation of plants and machinery

Services

Rapid hydraulics service



Full-service mobile rapid hydraulics service – contactable at no charge, any time

Fluid service



Professional consulting and oil care; provision of filter systems and elements

Industrial assembly



Scheduled activities to avoid unscheduled stoppages

Technical consulting



Individual solutions tuned precisely to the needs of our customers

Engineering/ Project planning



Planning for entire hydraulic systems – all from a single source

Cylinder repair



Manufacturer-independent repair of cylinders, pumps, motors and valves

Workshop containers



Mobile workshop containers for extreme application areas

Plant-in-plant production



Production facility at the customer's site – perfect synchronisation, rapid response times

Kitting



Ready-to-install, pre-assembled sets – individually adapted to the customer's needs

Kanban



Everything permanently in stock – structured inventory maintained at customer's site

Customer training



Wide-ranging seminar programme on all aspects of fluid technology, also conducted at customer's site

Hose identification



Replacement parts procurement without delay with X-CODE – unique, fast

Online-Shop



24/7 easy shopping, 80,000 items in stock:
www.hansa-flex.com/shop



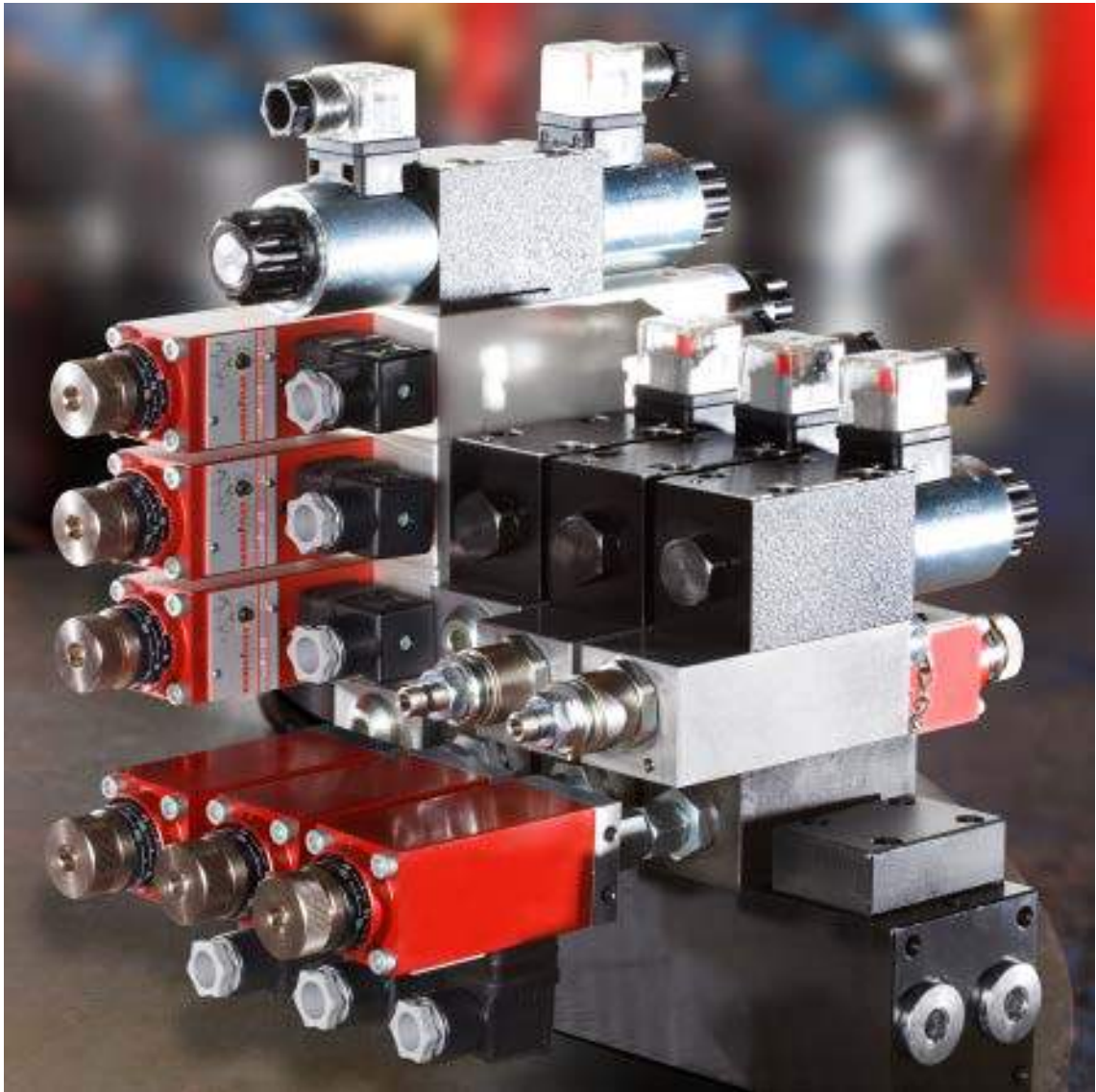

Hydraulic components

Pumps	
Hand pumps	44
Gear pumps	49
Axial piston pumps	71
Vane pumps	74
Flow divider	
Gear flow divider	75
Hydraulic motors	
Planetary motors	85
Accessories	94
Valves	
Pipeline installation valve	98
Cartridge valves	131
Valve housing for cartridge-type screw-in valves	145
CETOP directional control valves	166
CETOP sandwich body valves NG6	198
CETOP sandwich body valves NG10	211
CETOP sandwich body valves NG16	223
CETOP sandwich body valves NG25	226
Connector sub-bases for CETOP directional control valves	229
Plate mounting valves Cetop	239
SAE flange connection valves	245
Proportional valves CETOP	247
Rotary reversing valves	260
Solenoid-operated directional control valves for fitting into pipes	264
Monobloc manual directional control valves	266
Pressure gauge isolation valves	276
Valve accessories	277
Pressure accumulators	
Bladder accumulator	291
Diaphragm accumulator	292
Accessories	294
Heat exchangers	
Oil/air coolers	300
Accessories	302
Tanks	
Aluminium hydraulic tanks	303
Steel hydraulic tanks	306
Hydraulic tank accessories	309
Switches and sensors	
Pressure switches and pressure sensors	317
Level switch	325
Temperature switches	330
Unit components	
Components for hydraulic power units	334
Electric motors	
Alternating current / three-phase current	340
DC	350
Cylinders and cylinder components	
Standard cylinders with fastening	353
Standard cylinders without fastening	357
Mounting elements	361
Cylinder bases	370
Oil fittings	375
Guide housing	377
Pistons	380
Piston rods	386
Cylinder barrels	388
Accessories	389

High-pressure hydraulics 700 bar	
Pumps	390
Electrohydraulic pumps	391
cylinders	392
Presses	397
Ball valves	398
Valves	398
Pressure gauge	401
Accessories	402

HK PAM 014 R

Manual pump for pipeline installation

Material: Housing: cast iron, inner parts steel



Note: The pressure relief valves must be set according to the application.

Ordering information: Caution! Remember to order the hand lever HKPAM0290000!

Identification	Thread	Vdh (ccm) cc	Design	p max. bar	Pressure (30)* bar	Weight kg
HK PAM 014 20 00	1/2-3/8" IG	20	with manual drain	350	130	2,75
HK PAM 014 20 02	1/2-3/8" IG	20	without manual drain and pressure relief valve	350	130	2,70
HK PAM 014 20 04	1/2-3/8" IG	20	with pressure relief valve	350	130	2,90
HK PAM 014 40 00	1/2-1/2" IG	40	with manual drain	280	90	3,65
HK PAM 014 40 04	1/2-1/2" IG	40	with pressure relief valve	280	90	3,80

Vdh = conveying volume per double stroke Pressure (30)= pressure with hand force 30 daN with standard lever

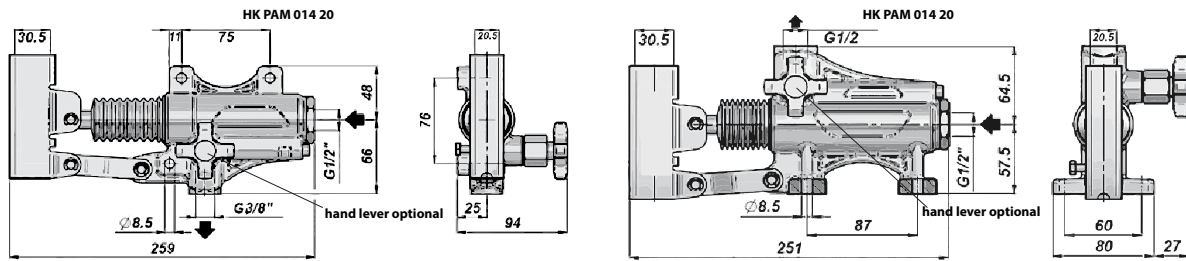

Web: <http://cat.hansa-flex.com/en/HKPAM014R>

Accessories:

HK PAM Hebel - Lever for PAM manual pump

HK PAM Faltenbalg - Bellows for PAM manual pump

HK PAM 014 T

Manual pump for tank installation

Scope of supply: incl. seal and screw set
Material: Housing: cast iron, inner parts steel

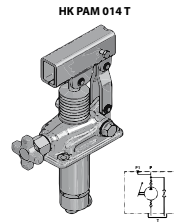

Note: The pressure relief valves must be set according to the application.

Ordering information: Caution! Remember to order the hand lever HKPAM0290000!

Identification	Thread	Vdh (ccm) cc	Design	p max. bar	Pressure (30)* bar	Weight kg
HK PAM 014 12 00	1x 3/8" AG	12	with manual drain	380	160	2,85
HK PAM 014 12 01	1x 3/8" AG	12	with manual drain and pressure relief valve	380	160	3,00
HK PAM 014 25 00	1x 3/8" AG	25	with manual drain	350	100	2,95
HK PAM 014 25 01	1x 3/8" AG	25	with manual drain and pressure relief valve	350	100	3,00
HK PAM 014 45 00	1x 3/8" AG	45	with manual drain	280	80	3,15
HK PAM 014 45 01	1x 3/8" AG	45	with manual drain and pressure relief valve	280	80	3,30

Vdh = conveying volume per double stroke Pressure (30)= pressure with hand force 30 daN with standard lever

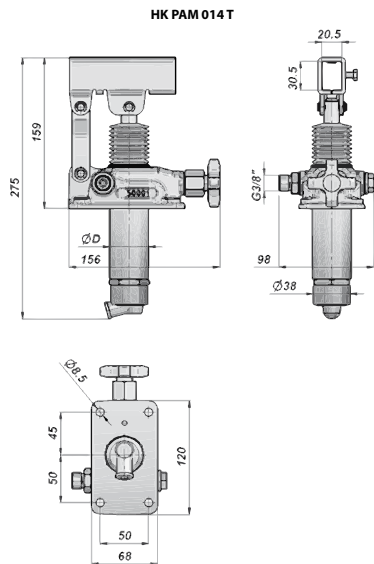

Web: <http://cat.hansa-flex.com/en/HKPAM014T>

Accessories:

HK PAM Hebel - Lever for PAM manual pump
 HK PM0 022 - Tank for PAM manual pump
 HK PAM Faltenbalg - Bellows for PAM manual pump

HK PAM 015 T

Manual pump for tank installation with directional control valve

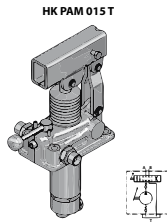

Scope of supply: incl. seal and screw set
Material: Housing: cast iron, inner parts steel

Note: The pressure relief valves must be set according to the application.

Ordering information: Caution! Remember to order the hand lever HKPAM0290000!

Identification	Thread	Vdh (ccm) cc	Design	p max. bar	Pressure (30)* bar	Weight kg
HK PAM 015 1200	2 x 3/8" AG	12	with 4/3-way valve	380	160	2,85
HK PAM 015 1202	2 x 3/8" AG	12	with pressure relief valve and 4/3-way valve	380	160	3,00
HK PAM 015 2500	2 x 3/8" AG	25	with 4/3-way valve	350	100	2,95
HK PAM 015 2502	2 x 3/8" AG	25	with pressure relief valve and 4/3-way valve	350	100	3,10
HK PAM 015 4500	2 x 3/8" AG	45	with 4/3-way valve	280	80	3,15
HK PAM 015 4502	2 x 3/8" AG	45	with pressure relief valve and 4/3-way valve	280	80	3,30

Vdh = conveying volume per double stroke Pressure (30)= pressure with hand force 30 daN with standard lever

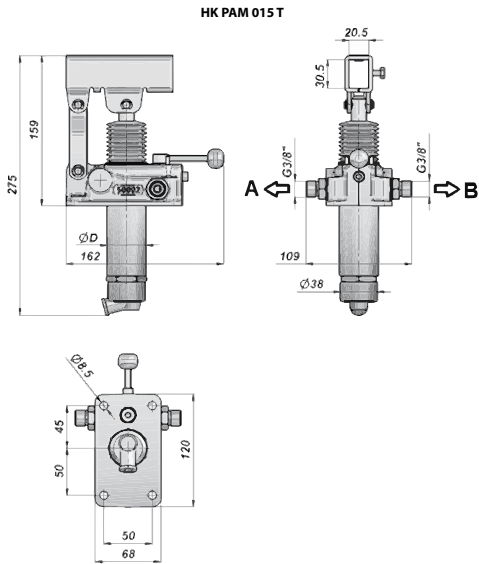

Web: <http://cat.hansa-flex.com/en/HKPAM015T>

Accessories:

- HK PAM Hebel - Lever for PAM manual pump
- HK PM0 022 - Tank for PAM manual pump
- HK PAM Faltenbalg - Bellows for PAM manual pump

HK PAM Faltenbalg

Bellows for PAM manual pump

Use: Spare for mounting via the pump plunger



Identification	Weight kg
HK PAM 019 01 01	0,1

Web: <http://cat.hansa-flex.com/en/HKPAMFALTENBALG>

Spare part for following products:

HK PAM 014 R - Manual pump for pipeline installation

HK PAM 014 T - Manual pump for tank installation

HK PAM 015 T - Manual pump for tank installation with directional control valve

HK PAM Hebel

Lever for PAM manual pump

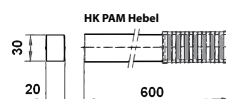

Identification	Dimensions	Weight kg
HK PAM 029 0000	20 x 30 x 600	0,71

Web: <http://cat.hansa-flex.com/en/HKPAMHEBEL>

Accessory for following products:

HK PAM 014 R - Manual pump for pipeline installation

HK PAM 014 T - Manual pump for tank installation

HK PAM 015 T - Manual pump for tank installation with directional control valve

HK PM0 022

Tank for PAM manual pump



Material: Steel, painted black

1

Identification	Contents	A	B	D	E	G	Weight
	L	mm	mm	mm	mm	mm	kg
HK PM0 022 0001	1,0	90	120	150	100	120	2,0
HK PM0 022 0002	2,0	90	120	150	100	180	2,2
HK PM0 022 0003	3,0	90	120	150	100	247	2,5
HK PM0 022 0005	5,0	90	195	175	175	200	4,5
HK PM0 022 0007	7,0	90	195	175	175	269	5,4
HK PM0 022 0010	10,0	90	195	175	175	376	6,8

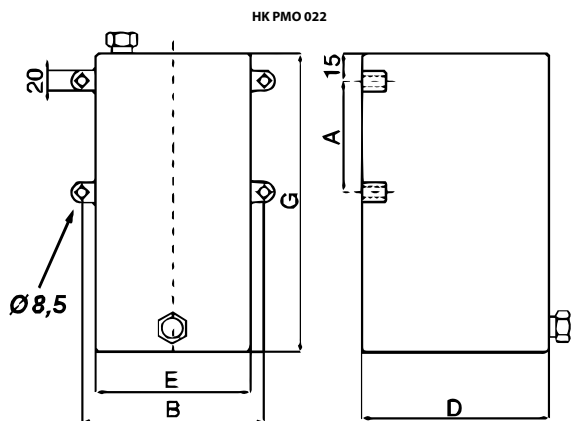

Web: <http://cat.hansa-flex.com/en/HKPM0022>

Accessory for following products:

HK PAM 014 T - Manual pump for tank installation

HK PAM 015 T - Manual pump for tank installation with directional control valve

HK OP ABBA

Gear pump, size 0 ABBA

European standard pump – hole pattern 66 – 22 dia. – cylinder dia. 7 – threaded fitting

Thread pressure side: G 1/4"

Thread suction side: G 1/4"



Ordering information: Further pump versions available on request

Identification	VFU (ccm) cc	p1 max. bar	p2 max. bar	p3 max. bar	A mm	B mm	Direction of rotation	Speed min. rpm	Speed max. rpm	Weight kg
HK OP 01 01 ABBA	0,16	220	240	260	56,0	26,2	anti-clockwise rotating	700	9000	0,40
HK OP 01 02 ABBA	0,16	220	240	260	56,0	26,2	clockwise rotating	700	9000	0,40
HK OP 02 01 ABBA	0,24	220	240	260	56,5	26,5	anti-clockwise rotating	700	9000	0,41
HK OP 02 02 ABBA	0,24	220	240	260	56,5	26,5	clockwise rotating	700	9000	0,41
HK OP 04 01 ABBA	0,45	220	240	260	58,0	27,3	anti-clockwise rotating	700	9000	0,42
HK OP 04 02 ABBA	0,45	220	240	260	58,0	27,3	clockwise rotating	700	9000	0,42
HK OP 05 01 ABBA	0,56	220	240	260	59,0	27,8	anti-clockwise rotating	700	9000	0,43
HK OP 05 02 ABBA	0,56	220	240	260	59,0	27,8	clockwise rotating	700	9000	0,43
HK OP 06 01 ABBA	0,75	220	240	260	60,5	28,5	anti-clockwise rotating	700	9000	0,44
HK OP 06 02 ABBA	0,75	220	240	260	60,5	28,5	clockwise rotating	700	9000	0,44
HK OP 07 01 ABBA	0,92	220	240	260	62,0	29,3	anti-clockwise rotating	700	6000	0,46
HK OP 07 02 ABBA	0,92	220	240	260	62,0	29,3	clockwise rotating	700	6000	0,46

VFU = conveying volume per revolution p1 = continuous pressure p2 = working pressure p3 = maximum pressure

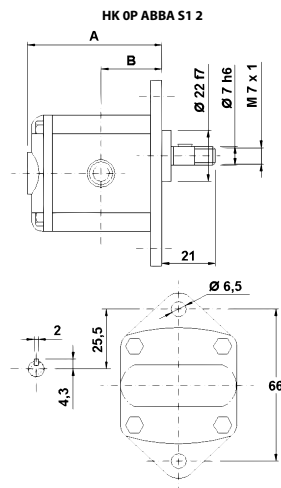

Web: <http://cat.hansa-flex.com/en/HKOPABBA>

HK K0

Gear pump, size 0 K0



European standard pump – hole pattern 66 – 22 dia. – flat splined shaft

Cover connection, suction side: G 1/4"
Flange connection, pressure side: Ø 5.00

1

Ordering information: Further pump versions available on request

Identification	VFU (ccm) cc	p1 max. bar	p2 max. bar	p3 max. bar	A mm	Direction of rotation	Speed min. rpm	Speed max. rpm	Weight kg
HK K 01	0,25	220	240	260	56,0	anti-clockwise rotating	700	9000	0,41
HK K 02	0,45	220	240	260	58,0	anti-clockwise rotating	700	9000	0,42
HK K 03	0,57	220	240	260	59,0	anti-clockwise rotating	700	9000	0,43
HK K 04	0,76	220	240	260	60,0	anti-clockwise rotating	700	9000	0,44
HK K M1	0,17	220	240	260	55,0	anti-clockwise rotating	700	9000	0,40

VFU = conveying volume per revolution p1 = continuous pressure p2 = working pressure p3 = maximum pressure

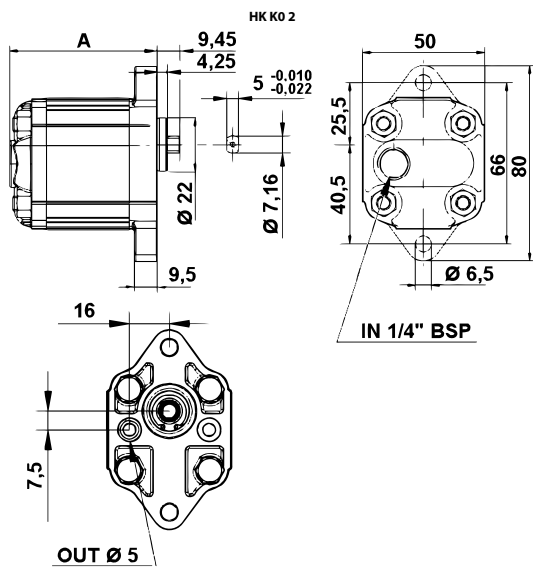

Web: <http://cat.hansa-flex.com/en/HKK0>

HK 1P GIIA

Gear pump, size 1 GIIA

European standard pump – hole pattern 73 x 56 – dia. 30 – taper 1:8 – flange fitting

Pitch circle pressure side: 30 / M6

Pitch circle suction side: 30 / M6



Ordering information: Further pump versions available on request

Identification	VFU (ccm)	p1 max.	p2 max.	p3 max.	A	B	Direction of rotation	Speed min.	Speed max.	Weight
	cc	bar	bar	bar	mm	mm		rpm	rpm	kg
HK 1P 16 11 GIIA	0,91	240	260	280	77,1	37,3	anti-clockwise rotating	700	6000	0,95
HK 1P 16 12 GIIA	0,91	240	260	280	77,1	37,3	clockwise rotating	700	6000	0,95
HK 1P 17 11 GIIA	1,17	250	270	290	78,0	37,8	anti-clockwise rotating	700	6000	0,97
HK 1P 17 12 GIIA	1,17	250	270	290	78,0	37,8	clockwise rotating	700	6000	0,97
HK 1P 18 11 GIIA	1,56	250	270	290	79,5	38,5	anti-clockwise rotating	700	6000	1,01
HK 1P 18 12 GIIA	1,56	250	270	290	79,5	38,5	clockwise rotating	700	6000	1,01
HK 1P 20 11 GIIA	2,08	250	270	290	81,5	39,5	anti-clockwise rotating	700	6000	1,03
HK 1P 20 12 GIIA	2,08	250	270	290	81,5	39,5	clockwise rotating	700	6000	1,03
HK 1P 21 11 GIIA	2,60	250	270	290	83,5	40,5	anti-clockwise rotating	700	6000	1,06
HK 1P 21 12 GIIA	2,60	250	270	290	83,5	40,5	clockwise rotating	700	6000	1,06
HK 1P 23 11 GIIA	3,12	240	260	290	85,5	41,5	anti-clockwise rotating	700	6000	1,09
HK 1P 23 12 GIIA	3,12	240	260	290	85,5	41,5	clockwise rotating	700	6000	1,09
HK 1P 25 11 GIIA	3,64	240	260	290	87,5	42,5	anti-clockwise rotating	700	6000	1,12
HK 1P 25 12 GIIA	3,64	240	260	290	87,5	42,5	clockwise rotating	700	6000	1,12
HK 1P 27 11 GIIA	4,16	240	260	290	89,5	43,5	anti-clockwise rotating	700	6000	1,17
HK 1P 27 12 GIIA	4,16	240	260	290	89,5	43,5	clockwise rotating	700	6000	1,17
HK 1P 29 11 GIIA	4,94	240	260	290	92,5	45,0	anti-clockwise rotating	700	6000	1,20
HK 1P 29 12 GIIA	4,94	240	260	290	92,5	45,0	clockwise rotating	700	6000	1,20
HK 1P 31 11 GIIA	5,85	190	260	290	96,0	46,8	anti-clockwise rotating	700	5000	1,26
HK 1P 31 12 GIIA	5,85	190	260	290	96,0	46,8	clockwise rotating	700	5000	1,26
HK 1P 32 11 GIIA	6,50	190	260	290	98,5	48,0	anti-clockwise rotating	700	5000	1,30
HK 1P 32 12 GIIA	6,50	190	260	290	98,5	48,0	clockwise rotating	700	5000	1,30
HK 1P 34 11 GIIA	7,54	190	210	260	102,5	50,0	anti-clockwise rotating	700	5000	1,36
HK 1P 34 12 GIIA	7,54	190	210	260	102,5	50,0	clockwise rotating	700	5000	1,36
HK 1P 36 11 GIIA	9,88	170	190	230	111,5	54,5	anti-clockwise rotating	700	4000	1,50
HK 1P 36 12 GIIA	9,88	170	190	230	111,5	54,5	clockwise rotating	700	4000	1,50

VFU = conveying volume per revolution p1 = continuous pressure p2 = working pressure p3 = maximum pressure

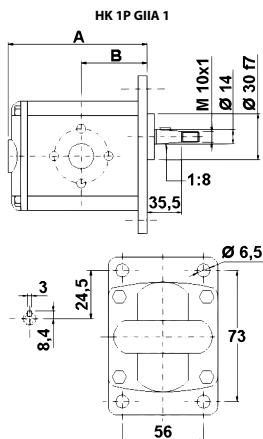

Web: <http://cat.hansa-flex.com/en/HK1PGIIA>

HK 1P FBBA

Gear pump, size 1 FBBA



European standard pump – hole pattern 71.9 x 52.4 – dia. 25.4 – taper 1:8 – threaded fitting

Thread pressure side: G 3/8"

Thread suction side: G 3/8"

Ordering information: Further pump versions available on request

Identification	VFU (ccm)	p1 max.	p2 max.	p3 max.	A	B	Direction of rotation	Speed min.	Speed max.	Weight
	cc	bar	bar	bar	mm	mm		rpm	rpm	
HK 1P 16 01 FBBA	0,91	240	260	280	77,1	37,3	anti-clockwise rotating	700	6000	0,95
HK 1P 16 02 FBBA	0,91	240	260	280	77,1	37,3	clockwise rotating	700	6000	0,95
HK 1P 17 01 FBBA	1,17	250	270	290	78,0	37,8	anti-clockwise rotating	700	6000	0,97
HK 1P 17 02 FBBA	1,17	250	270	290	78,0	37,8	clockwise rotating	700	6000	0,97
HK 1P 18 01 FBBA	1,56	250	270	290	79,5	38,5	anti-clockwise rotating	700	6000	1,01
HK 1P 18 02 FBBA	1,56	250	270	290	79,5	38,5	clockwise rotating	700	6000	1,01
HK 1P 20 01 FBBA	2,08	250	270	290	81,5	39,5	anti-clockwise rotating	700	6000	1,03
HK 1P 20 02 FBBA	2,08	250	270	290	81,5	39,5	clockwise rotating	700	6000	1,03
HK 1P 21 01 FBBA	2,60	250	270	290	83,5	40,5	anti-clockwise rotating	700	6000	1,06
HK 1P 21 02 FBBA	2,60	250	270	290	83,5	40,5	clockwise rotating	700	6000	1,06
HK 1P 23 01 FBBA	3,12	240	260	290	85,5	41,5	anti-clockwise rotating	700	6000	1,09
HK 1P 23 02 FBBA	3,12	240	260	290	85,5	41,5	clockwise rotating	700	6000	1,09
HK 1P 25 01 FBBA	3,64	240	260	290	87,5	42,5	anti-clockwise rotating	700	6000	1,12
HK 1P 25 02 FBBA	3,64	240	260	290	87,5	42,5	clockwise rotating	700	6000	1,12
HK 1P 27 01 FBBA	4,16	240	260	290	89,5	43,5	anti-clockwise rotating	700	6000	1,17
HK 1P 27 02 FBBA	4,16	240	260	290	89,5	43,5	clockwise rotating	700	6000	1,17
HK 1P 29 01 FBBA	4,94	250	280	300	92,5	45,0	anti-clockwise rotating	700	6000	1,20
HK 1P 29 02 FBBA	4,94	200	260	290	92,5	45,0	clockwise rotating	700	6000	1,20
HK 1P 31 01 FBBA	5,85	200	260	290	96,0	46,8	anti-clockwise rotating	700	5000	1,26
HK 1P 31 02 FBBA	5,85	190	260	290	96,0	46,8	clockwise rotating	700	5000	1,26
HK 1P 32 01 FBBA	6,50	190	260	290	98,5	48,0	anti-clockwise rotating	700	5000	1,30
HK 1P 32 02 FBBA	6,50	190	260	290	98,5	48,0	clockwise rotating	700	5000	1,30
HK 1P 34 01 FBBA	7,54	190	210	260	102,5	50,0	anti-clockwise rotating	700	5000	1,36
HK 1P 34 02 FBBA	7,54	190	210	260	102,5	50,0	clockwise rotating	700	5000	1,36
HK 1P 36 01 FBBA	9,88	170	190	230	111,5	54,5	anti-clockwise rotating	700	4000	1,50
HK 1P 36 02 FBBA	9,88	170	190	230	111,5	54,5	clockwise rotating	700	4000	1,50

VFU = conveying volume per revolution p1 = continuous pressure p2 = working pressure p3 = maximum pressure

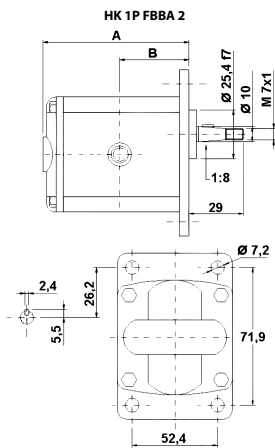

Web: <http://cat.hansa-flex.com/en/HK1PFBBA>

HK 1P FIIA

Gear pump, size 1 FIIA

European standard pump – hole pattern 71.9 x 52.4 – dia. 25.4 – taper 1:8 – flange fitting

Pitch circle pressure side: 30 / M6

Pitch circle suction side: 30 / M6



Ordering information: Further pump versions available on request

Identification	VFU (ccm) cc	p1 max.	p2 max.	p3 max.	A	B	Direction of rotation	Speed min.	Speed max.	Weight kg
		bar	bar	bar	mm	mm		rpm	rpm	
HK 1P 16 01 FIIA	0,91	240	260	280	77,1	37,3	anti-clockwise rotating	700	6000	0,95
HK 1P 16 02 FIIA	0,91	240	260	280	77,1	37,3	clockwise rotating	700	6000	0,95
HK 1P 17 01 FIIA	1,17	250	270	290	78,0	37,8	anti-clockwise rotating	700	6000	0,97
HK 1P 17 02 FIIA	1,17	250	270	290	78,0	37,8	clockwise rotating	700	6000	0,97
HK 1P1 8 01 FIIA	1,56	250	270	290	79,5	38,5	anti-clockwise rotating	700	6000	1,01
HK 1P 18 02 FIIA	1,56	250	270	290	79,5	38,5	clockwise rotating	700	6000	1,01
HK 1P 20 01 FIIA	2,08	250	270	290	81,5	39,5	anti-clockwise rotating	700	6000	1,03
HK 1P 20 02 FIIA	2,08	250	270	290	81,5	39,5	clockwise rotating	700	6000	1,03
HK 1P 21 01 FIIA	2,60	250	270	290	83,5	40,5	anti-clockwise rotating	700	6000	1,06
HK 1P 21 02 FIIA	2,60	250	270	290	83,5	40,5	clockwise rotating	700	6000	1,06
HK 1P 23 01 FIIA	3,12	240	260	290	85,5	41,5	anti-clockwise rotating	700	6000	1,09
HK 1P 23 02 FIIA	3,12	240	260	290	85,5	41,5	clockwise rotating	700	6000	1,09
HK 1P 25 01 FIIA	3,64	240	260	290	87,5	42,5	anti-clockwise rotating	700	6000	1,12
HK 1P 25 02 FIIA	3,64	240	260	290	87,5	42,5	clockwise rotating	700	6000	1,12
HK 1P 27 01 FIIA	4,16	240	260	290	89,5	43,5	anti-clockwise rotating	700	6000	1,17
HK 1P 27 02 FIIA	4,16	240	260	290	89,5	43,5	clockwise rotating	700	6000	1,17
HK 1P 29 01 FIIA	4,94	200	260	290	92,5	45,0	anti-clockwise rotating	700	6000	1,20
HK 1P 29 02 FIIA	4,94	200	260	290	92,5	45,0	clockwise rotating	700	6000	1,20
HK 1P 31 01 FIIA	5,85	190	260	290	96,0	46,8	anti-clockwise rotating	700	5000	1,26
HK 1P 31 02 FIIA	5,85	190	260	290	96,0	46,8	clockwise rotating	700	5000	1,26
HK 1P 32 01 FIIA	6,50	190	260	290	98,5	48,0	anti-clockwise rotating	700	5000	1,30
HK 1P 32 02 FIIA	6,50	190	260	290	98,5	48,0	clockwise rotating	700	5000	1,30
HK 1P 34 01 FIIA	7,54	190	210	260	102,5	50,0	anti-clockwise rotating	700	5000	1,36
HK 1P 34 02 FIIA	7,54	190	210	260	102,5	50,0	clockwise rotating	700	5000	1,36
HK 1P 36 01 FIIA	9,88	170	190	230	111,5	54,5	anti-clockwise rotating	700	4000	1,50
HK 1P 36 02 FIIA	9,88	170	190	230	111,5	54,5	clockwise rotating	700	4000	1,50

VFU = conveying volume per revolution p1 = continuous pressure p2 = working pressure p3 = maximum pressure

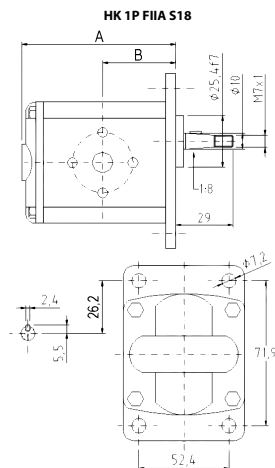

Web: <http://cat.hansa-flex.com/en/HK1PFIIA>

HK K1

Gear pump, size 1 K1



European standard pump – hole pattern 40 x 40 – dia. 32 – flat splined shaft

Design: housing type BH (attachment top right-hand, bottom left-hand)

Cover connection, suction

side: G 3/8"

Flange connection, pressure

side: Ø 9.25 (Quadring 9.25x1.78 NBR 70Sh)

1

Identification	VFU (ccm)	p1 max.	p3 max.	A	Direction of rotation	Speed min.	Speed max.	Weight
	cc	bar	bar	mm		rpm	rpm	
HK K 10	0,92	220	280	77,1	anti-clockwise rotating	700	6000	0,80
HK K 11	1,17	220	290	78,0	anti-clockwise rotating	700	6000	0,83
HK K 12	1,56	220	290	79,5	anti-clockwise rotating	700	6000	0,85
HK K 13	2,08	220	290	81,5	anti-clockwise rotating	700	6000	0,89
HK K 14	2,60	220	290	83,5	anti-clockwise rotating	700	6000	0,90
HK K 15	3,12	220	270	85,5	anti-clockwise rotating	700	6000	0,93
HK K 16	3,64	200	235	87,5	anti-clockwise rotating	700	6000	0,96
HK K 17	4,16	180	205	89,5	anti-clockwise rotating	700	6000	0,98
HK K 18	4,94	150	175	92,5	anti-clockwise rotating	700	6000	1,01
HK K 19	5,85	120	145	96,0	anti-clockwise rotating	700	5000	1,08
HK K 19A	6,50	100	130	97,5	anti-clockwise rotating	700	5000	1,09
HK K 20	7,54	80	120	102,5	anti-clockwise rotating	700	5000	1,08
HK K 21	9,88	70	110	111,5	anti-clockwise rotating	700	4000	1,08

VFU = conveying volume per revolution p1 = continuous pressure p3 = maximum pressure

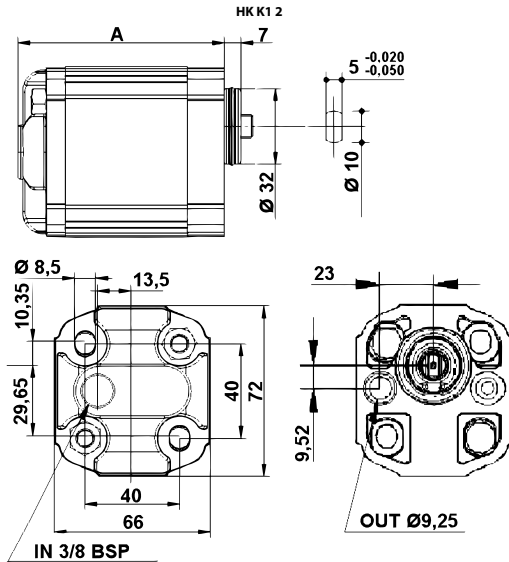

Web: <http://cat.hansa-flex.com/en/HKK1>

HK K1 CON

Gear pump, size 1 K1 CON

European standard pump – hole pattern 40 x 40 – dia. 32 – taper 1:8

Design: housing type BH (attachment top right-hand, bottom left-hand)

Cover connection, suction

side: G 3/8"

Flange connection, pressure

side: Ø 9.25 (Quadring 9.25x1.78 NBR 70Sh)



Identification	VFU (ccm)	p1 max.	p3 max.	A	Direction of rotation	Speed min.	Speed max.	Weight
	cc	bar	bar	mm		rpm	rpm	
HK K 10 CON	0,92	220	280	77,1	anti-clockwise rotating	700	6000	0,80
HK K 11 CON	1,17	220	290	78,0	anti-clockwise rotating	700	6000	0,83
HK K 12 CON	1,56	220	290	79,5	anti-clockwise rotating	700	6000	0,85
HK K 13 CON	2,08	220	290	81,5	anti-clockwise rotating	700	6000	0,89
HK K 14 CON	2,60	220	290	83,5	anti-clockwise rotating	700	6000	0,90
HK K 15 CON	3,12	220	300	85,5	anti-clockwise rotating	700	6000	0,93
HK K 16 CON	3,64	220	300	87,5	anti-clockwise rotating	700	6000	0,96
HK K 17 CON	4,16	220	300	89,5	anti-clockwise rotating	700	6000	0,98
HK K 18 CON	4,94	220	300	92,5	anti-clockwise rotating	700	6000	1,01
HK K 19 CON	5,85	220	300	96,0	anti-clockwise rotating	700	5000	1,08
HK K 19 A CON	6,50	220	300	97,5	anti-clockwise rotating	700	5000	1,09
HK K 20 CON	7,54	210	260	102,5	anti-clockwise rotating	700	5000	1,10
HK K 21 CON	9,88	190	230	111,5	anti-clockwise rotating	700	4000	1,20

VFU = conveying volume per revolution p1 = continuous pressure p3 = maximum pressure

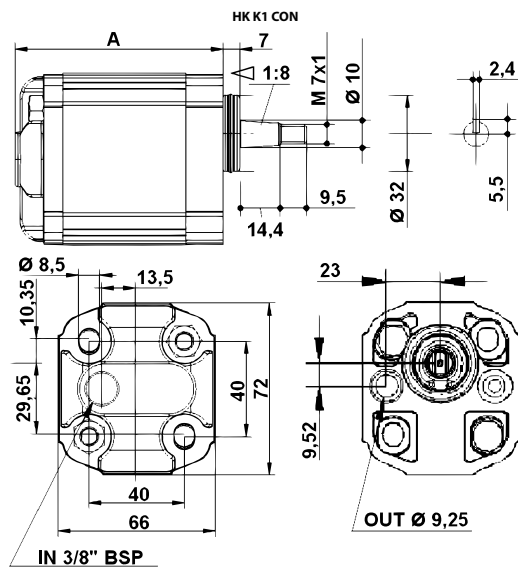

Web: <http://cat.hansa-flex.com/en/HKK1CON>

HK CBD ZLBA

Gear pump, size 1 CBD



European standard pump – hole pattern 40 x 40 – dia. 32 – taper 1:8

Design: Economy variant, housing type BH (attachment top right-hand, bottom left-hand)

Cover connection, suction

side: G 3/8"

Flange connection, pressure

side: Ø 9.25

Ordering information: Further pump versions available on request

Identification	VFU cc	p1 max. bar	p3 max. bar	A mm	Direction of rotation	Speed min. rpm	Speed max. rpm	Weight kg
HK CBD F211 L1Z LBA	1,1	200	250	74	anti-clockwise rotating	600	6000	0,77
HK CBD F216 L1Z LBA	1,6	200	250	76	anti-clockwise rotating	600	6000	0,80
HK CBD F221 L1Z LBA	2,1	200	250	78	anti-clockwise rotating	600	6000	0,82
HK CBD F227 L1Z LBA	2,7	200	250	80	anti-clockwise rotating	600	6000	0,85
HK CBD F232 L1Z LBA	3,2	200	250	82	anti-clockwise rotating	600	5000	0,87
HK CBD F237 L1Z LBA	3,7	200	250	84	anti-clockwise rotating	600	4500	0,90
HK CBD F242 L1Z LBA	4,2	200	250	86	anti-clockwise rotating	600	4000	0,92
HK CBD F258 L1Z LBA	5,8	160	200	92	anti-clockwise rotating	600	2900	1,00
HK CBD F280 L1Z LBA	8,0	160	200	100	anti-clockwise rotating	600	2100	1,10

VFU = conveying volume per revolution p1 = continuous pressure p3 = maximum pressure

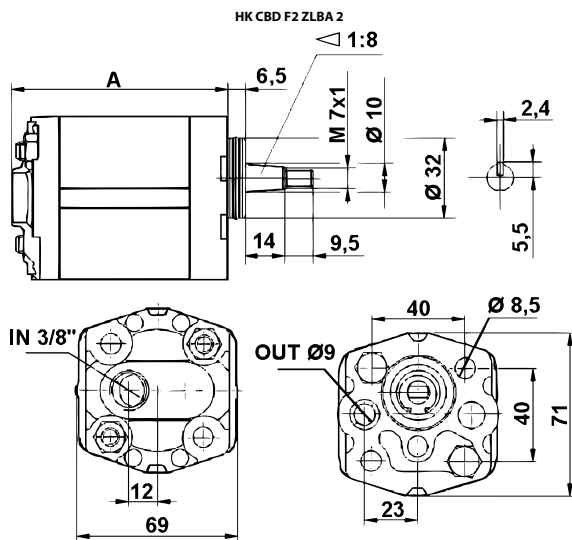

Web: <http://cat.hansa-flex.com/en/HK CBD ZLBA>

Gear pump, size 2 EOOA / EPOA / EQPA

European standard pump – hole pattern 96.2 x 71.5 – dia. 36.5 – taper 1:8 – flange fitting

Pitch circle pressure side: 30/M6 up to 22.8 VFU ccm, 40/M8 up to 26.2 VFU ccm

Pitch circle suction side: 30/M6 up to 10.8 VFU ccm, 40/M8 up to 14.4 VFU ccm



Ordering information: Further pump versions available on request

Identification	VFU	p1 max.	p2 max.	p3 max.	A	B	Direction of rotation	Speed min.	Speed max.	Weight
	cc	bar	bar	bar	mm	mm		rpm	rpm	
HK 2P 41 01 EOOA	4,2	260	280	300	87,2	41,7	anti-clockwise rotating	700	3500	2,20
HK 2P 41 02 EOOA	4,2	260	280	300	87,2	41,7	clockwise rotating	700	3500	2,20
HK 2P 43 01 EOOA	6,0	260	280	300	90,2	43,2	anti-clockwise rotating	700	3500	2,30
HK 2P 43 02 EOOA	6,0	260	280	300	90,2	43,2	clockwise rotating	700	3500	2,30
HK 2P 45 01 EOOA	8,4	260	280	300	94,2	45,2	anti-clockwise rotating	700	3500	2,40
HK 2P 45 02 EOOA	8,4	260	280	300	94,2	45,2	clockwise rotating	700	3500	2,40
HK 2P 47 01 EOOA	10,8	260	280	300	98,2	47,2	anti-clockwise rotating	700	3500	2,50
HK 2P 47 02 EOOA	10,8	260	280	300	98,2	47,2	clockwise rotating	700	3500	2,50
HK 2P 49 01 EPOA	14,4	250	270	290	104,2	50,2	anti-clockwise rotating	700	3500	2,70
HK 2P 49 02 EPOA	14,4	250	270	290	104,2	50,2	clockwise rotating	700	3500	2,70
HK 2P 51 01 EPOA	16,8	230	250	270	108,2	52,2	anti-clockwise rotating	700	3500	2,80
HK 2P 51 02 EPOA	16,8	230	250	270	108,2	52,2	clockwise rotating	700	3500	2,80
HK 2P 53 01 EPOA	19,2	210	230	250	112,2	54,2	anti-clockwise rotating	700	3000	2,90
HK 2P 53 02 EPOA	19,2	210	230	250	112,2	54,2	clockwise rotating	700	3000	2,90
HK 2P 55 01 EPOA	22,8	200	220	240	118,2	57,2	anti-clockwise rotating	700	3000	3,05
HK 2P 55 02 EPOA	22,8	200	220	240	118,2	57,2	clockwise rotating	700	3000	3,05
HK 2P 57 01 EQPA	26,2	120	140	160	122,2	59,2	anti-clockwise rotating	700	3000	3,15
HK 2P 57 02 EQPA	26,2	120	140	160	122,2	59,2	clockwise rotating	700	3000	3,15
HK 2P 61 01 EQPA	34,2	100	120	140	137,2	66,7	anti-clockwise rotating	700	2500	3,60
HK 2P 61 02 EQPA	34,2	100	120	140	137,2	66,7	clockwise rotating	700	2500	3,60
HK 2P 59 01 EQPA	30,0	110	130	150	130,2	63,2	anti-clockwise rotating	700	2500	3,40
HK 2P 59 02 EQPA	30,0	110	130	150	130,2	63,2	clockwise rotating	700	2500	3,40
HK 2P 63 01 EQPA	39,6	90	110	130	146,2	71,2	anti-clockwise rotating	700	2000	3,80
HK 2P 63 02 EQPA	39,6	90	110	130	146,2	71,2	clockwise rotating	700	2000	3,80

VFU = conveying volume per revolution p1 = continuous pressure p2 = working pressure p3 = maximum pressure

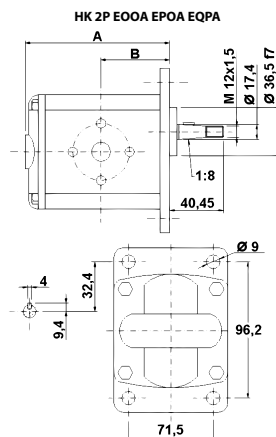

Web: <http://cat.hansa-flex.com/en/HK2PEXXA>

HK CBTF

Gear pump, size 2 CBTF



European standard pump – hole pattern 96.2 x 71.5 – dia. 36.5 – taper 1:8 – flange fitting

Design: Economy variant

Pitch circle pressure side: 30 / M6

Pitch circle suction side: 30/M6 up to 8.00 VFU ccm, 40/M8 up to 10.00 VFU ccm

Identification	VFU cc	p1 max. bar	p3 max. bar	A mm	B mm	Direction of rotation	Speed min. rpm	Speed max. rpm	Weight kg
HK CBTF 304 F1Z 0A	4	200	250	99	45	clockwise rotating	600	3000	3,3
HK CBTF 304 F1Z LA	4	200	250	99	45	anti-clockwise rotating	600	3000	3,3
HK CBTF 306 F1Z 0A	6	200	250	101	46	clockwise rotating	600	3000	3,4
HK CBTF 306 F1Z LA	6	200	250	101	46	anti-clockwise rotating	600	3000	3,4
HK CBTF 308 F1Z 0A	8	200	250	104	48	clockwise rotating	600	3000	3,5
HK CBTF 308 F1Z LA	8	200	250	104	48	anti-clockwise rotating	600	3000	3,5
HK CBTF 310 F1Z 0A	10	200	250	107	49	clockwise rotating	600	3000	3,6
HK CBTF 310 F1Z LA	10	200	250	107	49	anti-clockwise rotating	600	3000	3,6
HK CBTF 314 F1Z 0A	14	200	250	113	52	clockwise rotating	600	3000	3,8
HK CBTF 314 F1Z LA	14	200	250	113	52	anti-clockwise rotating	600	3000	3,8
HK CBTF 316 F1Z 0A	16	200	250	117	54	clockwise rotating	600	3000	3,9
HK CBTF 316 F1Z LA	16	200	250	117	54	anti-clockwise rotating	600	3000	3,9
HK CBTF 320 F1Z 0A	20	200	250	123	57	clockwise rotating	600	3000	4,0
HK CBTF 320 F1Z LA	20	200	250	123	57	anti-clockwise rotating	600	3000	4,0
HK CBTF 325 F1Z 0A	25	200	250	131	61	clockwise rotating	600	3000	4,0
HK CBTF 325 F1Z LA	25	200	250	131	61	anti-clockwise rotating	600	3000	4,0

VFU = conveying volume per revolution p1 = continuous pressure p3 = maximum pressure

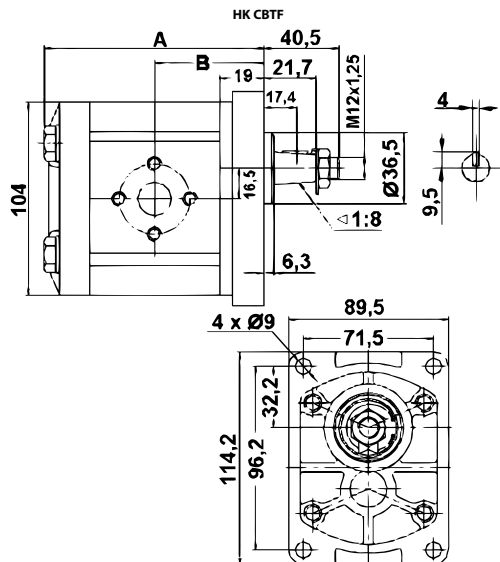

Web: <http://cat.hansa-flex.com/en/HKCBTF>

HK GR33

Gear pump, size 2, low noise

European standard pump – hole pattern 96.2 x 71.5 – dia. 36.5 – taper 1:8 – flange fitting

Due to the special tooth design these pumps achieve a significantly lower noise level. (By comparison: standard gear pump 65-75 dB; gear pump HK GR33 47-57 dB; values for speed range 500-3000 rev/min)

Design: low noise

Pitch circle pressure side: 30 / M6

Pitch circle suction side: 40 / M8



Ordering information: Further pump versions available on request

Identification	VFU	p1 max.	p2 max.	p3 max.	A	B	Direction of rotation	Speed min.	Speed max.	Weight
	cc	bar	bar	bar	mm	mm		rpm	rpm	
HK GR33 2C 010 F2AC4 F D	10,0	275	280	300	122,5	53,7	clockwise rotating	500	3000	3,60
HK GR33 2C 013 F2AC4 F D	13,0	265	270	290	127,4	56,2	clockwise rotating	500	3000	3,80
HK GR33 2C 015 F2AC4 F D	15,0	240	250	270	132,4	58,7	clockwise rotating	500	3000	3,90
HK GR33 2C 018 F2AC4 F D	18,0	205	250	270	138,2	61,6	clockwise rotating	500	3000	4,00

VFU = conveying volume per revolution p1 = continuous pressure p2 = working pressure p3 = maximum pressure

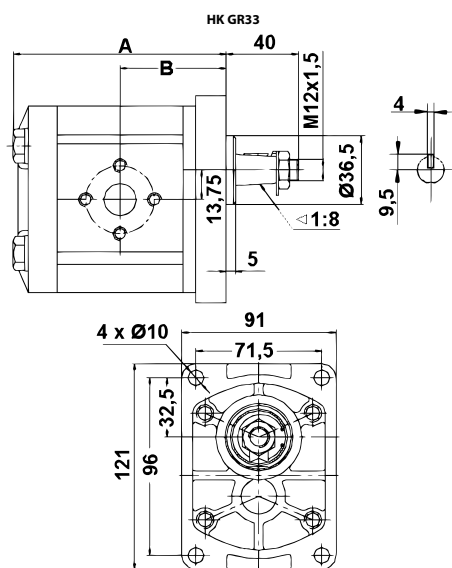

Web: <http://cat.hansa-flex.com/en/HKGR33>

HK 2P ExBA

Gear pump, size 2 EBBA / ECBA



European standard pump – hole pattern 96.2 x 71.5 – dia. 36.5 – taper 1:8 – threaded fitting

Thread pressure side: G 1/2"

Thread suction side: G 1/2" up to 10.8 VFU ccm, G 3/4" up to 14.4 VFU ccm

Ordering information: Further pump versions available on request

Identification	VFU cc	p1 max. bar	p2 max. bar	p3 max. bar	A mm	B mm	Direction of rotation	Speed min. rpm	Speed max. rpm	Weight kg
HK 2P 41 01 EBBA	4,2	260	280	300	87,2	41,7	anti-clockwise rotating	700	3500	2,20
HK 2P 41 02 EBBA	4,2	260	280	300	87,2	41,7	clockwise rotating	700	3500	2,20
HK 2P 43 01 EBBA	6,0	260	280	300	90,2	43,2	anti-clockwise rotating	700	3500	2,30
HK 2P 43 02 EBBA	6,0	260	280	300	90,2	43,2	clockwise rotating	700	3500	2,30
HK 2P 45 01 EBBA	8,4	260	280	300	94,2	45,2	anti-clockwise rotating	700	3500	2,40
HK 2P 45 02 EBBA	8,4	260	280	300	94,2	45,2	clockwise rotating	700	3500	2,40
HK 2P 47 01 EBBA	10,8	260	280	300	98,2	47,2	anti-clockwise rotating	700	3500	2,50
HK 2P 47 02 EBBA	10,8	260	280	300	98,2	47,2	clockwise rotating	700	3500	2,50
HK 2P 49 01 ECBA	14,4	250	270	290	104,2	50,2	anti-clockwise rotating	700	3500	2,70
HK 2P 49 02 ECBA	14,4	250	270	290	104,2	50,2	clockwise rotating	700	3500	2,70
HK 2P 51 01 ECBA	16,8	230	250	270	108,2	52,2	anti-clockwise rotating	700	3500	2,80
HK 2P 51 02 ECBA	16,8	230	250	270	108,2	52,2	clockwise rotating	700	3500	2,80
HK 2P 53 01 ECBA	19,2	210	230	250	112,2	54,2	anti-clockwise rotating	700	3000	2,90
HK 2P 53 02 ECBA	19,2	210	230	250	112,2	54,2	clockwise rotating	700	3000	2,90
HK 2P 55 01 ECBA	22,8	200	220	240	118,2	57,2	anti-clockwise rotating	700	3000	3,05
HK 2P 55 02 ECBA	22,8	200	220	240	118,2	57,2	clockwise rotating	700	3000	3,05

VFU = conveying volume per revolution p1 = continuous pressure p2 = working pressure p3 = maximum pressure

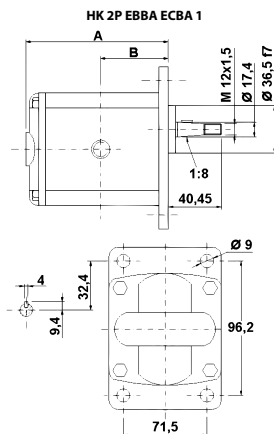

Web: <http://cat.hansa-flex.com/en/HK2PEXBA>

HK 2P 4 FSRA

Gear pump, size 2 FSRA

German standard pump – hole pattern 100 x 72 – dia. 80 – taper 1:5 – flange fitting

Pitch circle pressure side: 35 / M6

Pitch circle suction side: 40 / M6



Ordering information: Further pump versions available on request

Identification	VFU cc	p1 max.	p2 max.	p3 max.	A	B	Direction of rotation	Speed min.	Speed max.	Weight kg
		bar	bar	bar	mm	mm		rpm	rpm	
HK 2P 41 41 FSRA	4,2	260	280	300	87,2	41,1	anti-clockwise rotating	700	3500	2,33
HK 2P 41 42 FSRA	4,2	260	280	300	87,2	41,1	clockwise rotating	700	3500	2,33
HK 2P 43 41 FSRA	6,0	260	280	300	90,2	41,1	anti-clockwise rotating	700	3500	2,43
HK 2P 43 42 FSRA	6,0	260	280	300	90,2	41,1	clockwise rotating	700	3500	2,43
HK 2P 45 41 FSRA	8,4	260	280	300	94,2	43,1	anti-clockwise rotating	700	3500	2,53
HK 2P 45 42 FSRA	8,4	260	280	300	94,2	43,1	clockwise rotating	700	3500	2,53
HK 2P 47 41 FSRA	10,8	260	280	300	98,2	47,5	anti-clockwise rotating	700	3500	2,63
HK 2P 47 42 FSRA	10,8	260	280	300	98,2	47,5	clockwise rotating	700	3500	2,63
HK 2P 49 41 FSRA	14,4	250	270	290	104,2	47,5	anti-clockwise rotating	700	3500	2,73
HK 2P 49 42 FSRA	14,4	250	270	290	104,2	47,5	clockwise rotating	700	3500	2,73
HK 2P 51 41 FSRA	16,8	230	250	270	108,2	47,5	anti-clockwise rotating	700	3500	2,83
HK 2P 51 42 FSRA	16,8	230	250	270	108,2	47,5	clockwise rotating	700	3500	2,83
HK 2P 53 41 FSRA	19,2	210	230	250	112,2	47,5	anti-clockwise rotating	700	3000	2,93
HK 2P 53 42 FSRA	19,2	210	230	250	112,2	47,5	clockwise rotating	700	3000	2,93
HK 2P 55 41 FSRA	22,8	200	220	240	118,2	55,0	anti-clockwise rotating	700	3000	3,18
HK 2P 55 42 FSRA	22,8	200	220	240	118,2	55,0	clockwise rotating	700	3000	3,18
HK 2P 57 41 FSRA	26,2	170	190	210	124,7	55,0	anti-clockwise rotating	700	3000	3,28
HK 2P 57 42 FSRA	26,2	170	190	210	124,7	55,0	clockwise rotating	700	3000	3,28

VFU = conveying volume per revolution p1 = continuous pressure p2 = working pressure p3 = maximum pressure

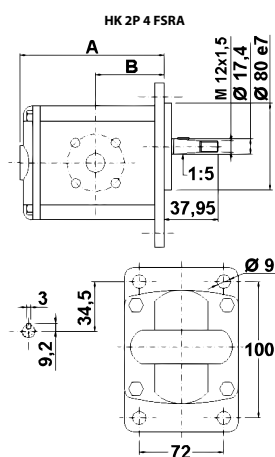

Web: <http://cat.hansa-flex.com/en/HK2P4FSRA>

HK 2P ISRA

Gear pump, size 2 ISRA



SAE A pump – hole pattern 106.4 – dia. 82.5 – splined shaft SAE J 498 – flange fitting

Pitch circle pressure side: 35 / M6

Pitch circle suction side: 40 / M6

Ordering information: Further pump versions available on request

Identification	VFU cc	p1 max. bar	p2 max. bar	p3 max. bar	A mm	B mm	Direction of rotation	Speed min. rpm	Speed max. rpm	Weight kg
HK 2P 41 51 ISRA	4,2	260	280	300	88	39,4	anti-clockwise rotating	700	3500	2,28
HK 2P 41 52 ISRA	4,2	260	280	300	88	39,4	clockwise rotating	700	3500	2,28
HK 2P 43 51 ISRA	6,0	260	280	300	91	39,4	anti-clockwise rotating	700	3500	2,38
HK 2P 43 52 ISRA	6,0	260	280	300	91	39,4	clockwise rotating	700	3500	2,38
HK 2P 45 51 ISRA	8,4	260	280	300	95	41,4	anti-clockwise rotating	700	3500	2,48
HK 2P 45 52 ISRA	8,4	260	280	300	95	41,4	clockwise rotating	700	3500	2,48
HK 2P 47 51 ISRA	10,8	260	280	300	99	45,8	anti-clockwise rotating	700	3500	2,58
HK 2P 47 52 ISRA	10,8	260	280	300	99	45,8	clockwise rotating	700	3500	2,58
HK 2P 49 51 ISRA	14,4	250	270	290	105	45,8	anti-clockwise rotating	700	3500	2,78
HK 2P 49 52 ISRA	14,4	250	270	290	105	45,8	clockwise rotating	700	3500	2,78
HK 2P 51 51 ISRA	16,8	230	250	270	109	45,8	anti-clockwise rotating	700	3500	2,88
HK 2P 51 52 ISRA	16,8	230	250	270	109	45,8	clockwise rotating	700	3500	2,88
HK 2P 53 51 ISRA	19,2	210	230	250	113	45,8	anti-clockwise rotating	700	3000	2,98
HK 2P 53 52 ISRA	19,2	210	230	250	113	45,8	clockwise rotating	700	3000	2,98
HK 2P 55 51 ISRA	22,8	200	220	240	119	53,3	anti-clockwise rotating	700	3000	3,13
HK 2P 55 52 ISRA	22,8	200	220	240	119	53,3	clockwise rotating	700	3000	3,13

VFU = conveying volume per revolution p1 = continuous pressure p2 = working pressure p3 = maximum pressure

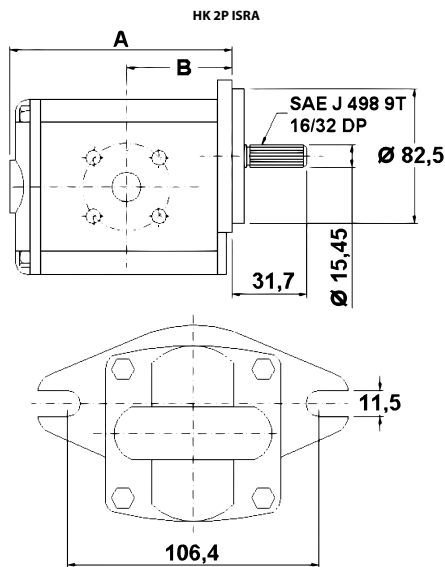

Web: <http://cat.hansa-flex.com/en/HK2PISRA>

HK 2P CSRA

Gear pump, size 2 CSRA

German standard pump – hole pattern 60 x 60 – dia. 52 – claw 16.8 x 8 – flange fitting

Design: housing type BH (attachment top right-hand, bottom left-hand)

Pitch circle pressure side: 35 / M6

Pitch circle suction side: 40 / M6

Scope of supply: incl. coupling piece



Ordering information: Further pump versions available on request

Identification	VFU cc	p1 max.	p2 max.	p3 max.	A mm	B mm	Direction of rotation	Speed min. rpm	Speed max. rpm	Weight kg
		bar	bar	bar						
HK 2P 41 31 CSRA	4,2	260	280	300	87,2	38,6	anti-clockwise rotating	700	3500	2,10
HK 2P 41 32 CSRA	4,2	260	280	300	87,2	38,6	clockwise rotating	700	3500	2,10
HK 2P 43 31 CSRA	6,0	260	280	300	90,2	38,6	anti-clockwise rotating	700	3500	2,20
HK 2P 43 32 CSRA	6,0	260	280	300	90,2	38,6	clockwise rotating	700	3500	2,20
HK 2P 45 31 CSRA	8,4	260	280	300	94,2	40,6	anti-clockwise rotating	700	3500	2,30
HK 2P 45 32 CSRA	8,4	260	280	300	94,2	40,6	clockwise rotating	700	3500	2,30
HK 2P 47 31 CSRA	10,8	260	280	300	98,2	45,0	anti-clockwise rotating	700	3500	2,40
HK 2P 47 32 CSRA	10,8	260	280	300	98,2	45,0	clockwise rotating	700	3500	2,40
HK 2P 49 31 CSRA	14,4	250	270	290	104,2	45,0	anti-clockwise rotating	700	3500	2,60
HK 2P 49 32 CSRA	14,4	250	270	290	104,2	45,0	clockwise rotating	700	3500	2,60
HK 2P 51 31 CSRA	16,8	230	250	270	108,2	45,0	anti-clockwise rotating	700	3500	2,70
HK 2P 51 32 CSRA	16,8	230	250	270	108,2	45,0	clockwise rotating	700	3500	2,70
HK 2P 53 31 CSRA	19,2	210	230	250	112,2	45,0	anti-clockwise rotating	700	3000	2,80
HK 2P 53 32 CSRA	19,2	210	230	250	112,2	45,0	clockwise rotating	700	3000	2,80
HK 2P 55 31 CSRA	22,8	200	220	240	118,2	52,5	anti-clockwise rotating	700	3000	2,95
HK 2P 55 32 CSRA	22,8	200	220	240	118,2	52,5	clockwise rotating	700	3000	2,95

VFU = conveying volume per revolution p1 = continuous pressure p2 = working pressure p3 = maximum pressure

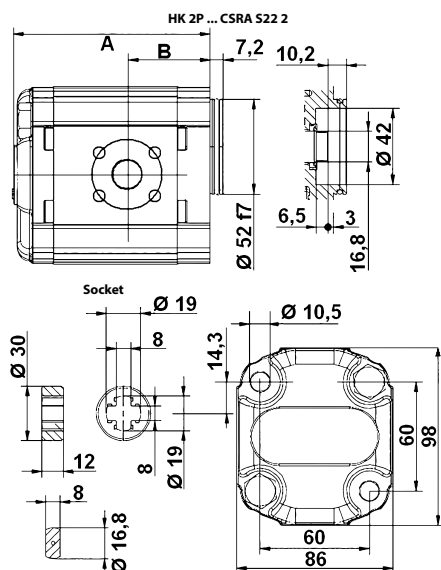

Web: <http://cat.hansa-flex.com/en/HK2PCSRA>

HK 2P 1 FSRA

Gear pump, size 2 FSRA



German standard pump – hole pattern 60 x 60 – dia. 50 – taper 1:5 – flange fitting

Design: housing type BH (attachment top right-hand, bottom left-hand)
Pitch circle pressure side: 35 / M6
Pitch circle suction side: 40 / M6

Ordering information: Further pump versions available on request

Identification	VFU cc	p1 max. bar	p2 max. bar	p3 max. bar	A mm	B mm	Direction of rotation	Speed min. rpm	Speed max. rpm	Weight kg
HK 2P 41 11 FSRA	4,2	260	280	300	87,2	38,6	anti-clockwise rotating	700	3500	2,10
HK 2P 41 12 FSRA	4,2	260	280	300	87,2	38,6	clockwise rotating	700	3500	2,10
HK 2P 43 11 FSRA	6,0	260	280	300	90,2	38,6	anti-clockwise rotating	700	3500	2,20
HK 2P 43 12 FSRA	6,0	260	280	300	90,2	38,6	clockwise rotating	700	3500	2,20
HK 2P 45 11 FSRA	8,4	260	280	300	94,2	40,6	anti-clockwise rotating	700	3500	2,30
HK 2P 45 12 FSRA	8,4	260	280	300	94,2	40,6	clockwise rotating	700	3500	2,30
HK 2P 47 11 FSRA	10,8	260	280	300	98,2	45,0	anti-clockwise rotating	700	3500	2,40
HK 2P 47 12 FSRA	10,8	260	280	300	98,2	45,0	clockwise rotating	700	3500	2,40
HK 2P 49 11 FSRA	14,4	250	270	290	104,2	45,0	anti-clockwise rotating	700	3500	2,60
HK 2P 49 12 FSRA	14,4	250	270	290	104,2	45,0	clockwise rotating	700	3500	2,60
HK 2P 51 11 FSRA	16,8	230	250	270	108,2	45,0	anti-clockwise rotating	700	3500	2,70
HK 2P 51 12 FSRA	16,8	230	250	270	108,2	45,0	clockwise rotating	700	3500	2,70
HK 2P 53 11 FSRA	19,2	210	230	250	112,2	45,0	anti-clockwise rotating	700	3000	2,80
HK 2P 53 12 FSRA	19,2	210	230	250	112,2	45,0	clockwise rotating	700	3000	2,80
HK 2P 55 11 FSRA	22,8	200	220	240	118,2	52,5	anti-clockwise rotating	700	3000	2,95
HK 2P 55 12 FSRA	22,8	200	220	240	118,2	52,5	clockwise rotating	700	3000	2,95

VFU = conveying volume per revolution p1 = continuous pressure p2 = working pressure p3 = maximum pressure

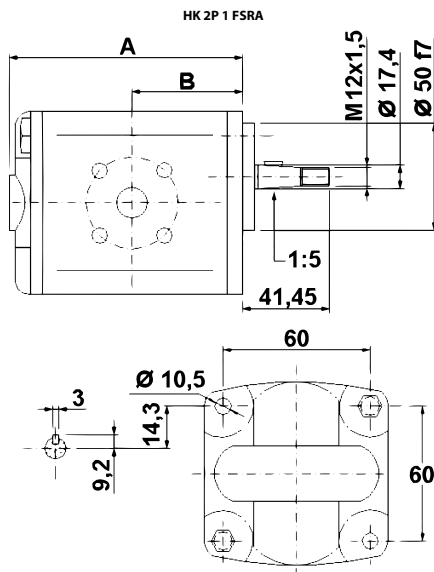

Web: <http://cat.hansa-flex.com/en/HK2P1FSRA>

HK 2P 2 FSRA

Gear pump, size 2 FSRA

German standard pump – hole pattern 60 x 60 – dia. 50 – taper 1:5 – flange fitting

Design: Housing Type HY (mounting top left, bottom right)

Pitch circle pressure side: 35 / M6

Pitch circle suction side: 40 / M6



Ordering information: Further pump versions available on request

Identification	VFU cc	p1 max. bar	p2 max. bar	p3 max. bar	A mm	B mm	Direction of rotation	Speed min. rpm	Speed max. rpm	Weight kg
HK 2P 41 21 FSRA	4,2	260	280	300	87,2	38,6	anti-clockwise rotating	700	3500	2,10
HK 2P 41 22 FSRA	4,2	260	280	300	87,2	38,6	clockwise rotating	700	3500	2,10
HK 2P 43 21 FSRA	6,0	260	280	300	90,2	38,6	anti-clockwise rotating	700	3500	2,20
HK 2P 43 22 FSRA	6,0	260	280	300	90,2	38,6	clockwise rotating	700	3500	2,20
HK 2P 45 21 FSRA	8,4	260	280	300	94,2	40,6	anti-clockwise rotating	700	3500	2,30
HK 2P 45 22 FSRA	8,4	260	280	300	94,2	40,6	clockwise rotating	700	3500	2,30
HK 2P 47 21 FSRA	10,8	260	280	300	98,2	45,0	anti-clockwise rotating	700	3500	2,40
HK 2P 47 22 FSRA	10,8	260	280	300	98,2	45,0	clockwise rotating	700	3500	2,40
HK 2P 49 21 FSRA	14,4	250	270	290	104,2	45,0	anti-clockwise rotating	700	3500	2,60
HK 2P 49 22 FSRA	14,4	250	270	290	104,2	45,0	clockwise rotating	700	3500	2,60
HK 2P 51 21 FSRA	16,8	230	250	270	108,2	45,0	anti-clockwise rotating	700	3500	2,70
HK 2P 51 22 FSRA	16,8	230	250	270	108,2	45,0	clockwise rotating	700	3500	2,70
HK 2P 53 21 FSRA	19,2	210	230	250	112,5	45,0	anti-clockwise rotating	700	3000	2,80
HK 2P 53 22 FSRA	19,2	210	230	250	112,5	45,0	clockwise rotating	700	3000	2,80
HK 2P 55 21 FSRA	22,8	200	220	240	118,2	52,5	anti-clockwise rotating	700	3000	2,95
HK 2P 55 22 FSRA	22,8	200	220	240	118,2	52,5	clockwise rotating	700	3000	2,95

VFU = conveying volume per revolution p1 = continuous pressure p2 = working pressure p3 = maximum pressure

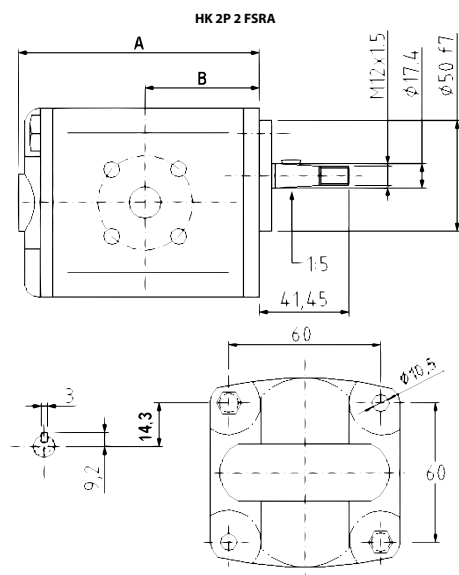

Web: <http://cat.hansa-flex.com/en/HK2P2FSRA>

HK X3P ABAA/ACBA**Gear pump, size 3 X3P**

European standard pump – hole pattern 128 x 98 – dia. 50.8 – taper 1:8 – flange fitting
Pitch circle pressure side: 40/M8 up to 50.88 VFU ccm, 51/M10 up to 60.81 VFU ccm
Pitch circle suction side: 51/M10 up to 50.88 VFU ccm, 62/M10 up to 60.81 VFU ccm

Ordering information: Further pump versions available on request

Identification	VFU (ccm) cc	p2 max. bar	p3 max. bar	A mm	B mm	Direction of rotation	Speed min.	Speed max.	Weight kg
							rpm	rpm	
HK X3P 70 01 ABAA	21,10	250	270	127	63,5	anti-clockwise rotating	700	3000	7,15
HK X3P 70 02 ABAA	21,10	250	270	127	63,5	clockwise rotating	700	3000	7,15
HK X3P 72 01 ABAA	26,06	250	270	131	65,5	anti-clockwise rotating	700	3000	7,25
HK X3P 72 02 ABAA	26,06	250	270	131	65,5	clockwise rotating	700	3000	7,25
HK X3P 74 01 ABAA	32,27	250	270	136	68,0	anti-clockwise rotating	700	3000	7,39
HK X3P 74 02 ABAA	32,27	250	270	136	68,0	clockwise rotating	700	3000	7,39
HK X3P 78 01 ABAA	38,47	250	270	141	70,5	anti-clockwise rotating	700	2800	7,52
HK X3P 78 02 ABAA	38,47	250	270	141	70,5	clockwise rotating	700	2800	7,52
HK X3P 79 01 ABAA	43,44	250	270	145	72,5	anti-clockwise rotating	700	2800	7,63
HK X3P 79 02 ABAA	43,44	250	270	145	72,5	clockwise rotating	700	2800	7,63
HK X3P 81 01 ABAA	50,88	230	250	151	75,5	anti-clockwise rotating	700	2800	7,79
HK X3P 81 02 ABAA	50,88	230	250	151	75,5	clockwise rotating	700	2800	7,79
HK X3P 83 01 ACBA	60,81	230	250	159	79,5	anti-clockwise rotating	700	2300	8,01
HK X3P 83 02 ACBA	60,81	230	250	159	79,5	clockwise rotating	700	2300	8,01
HK X3P 87 01 ACBA	74,46	180	200	170	85,0	anti-clockwise rotating	700	2300	8,30
HK X3P 87 02 ACBA	74,46	180	200	170	85,0	clockwise rotating	700	2300	8,30

VFU = conveying volume per revolution p2 = working pressure p3 = maximum pressure

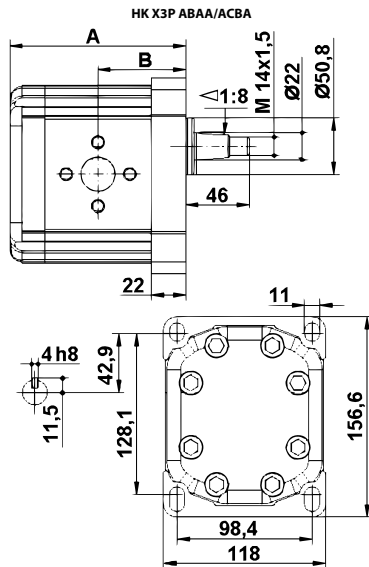

Web: <http://cat.hansa-flex.com/en/HKX3PABAAACBA>

HK CBD1 F5

Gear pump, size 3 CBD1F5

European standard pump – hole pattern 128 x 98 – dia. 50.8 – taper 1:8 – flange fitting

Design: Economy variant

Pitch circle pressure side: 51 / M10

Pitch circle suction side: 51/M10 from 20 to 46 VFU ccm, 62/M10 from 55 to 63 VFU ccm



Ordering information: Further pump versions available on request

Identification	VFU (ccm)	p2 max.	p3 max.	A	B	Direction of rotation	Speed max.	Weight
	cc	bar	bar	mm	mm		rpm	
HK CBD1F5 20 F37 Z20	20,00	200	250	119,0	58,75	clockwise rotating	2000	7,00
HK CBD1F5 20 F37 Z2L	20,00	200	250	119,0	58,75	anti-clockwise rotating	2000	7,00
HK CBD1F5 26 F37 Z20	26,00	200	250	123,5	61,00	clockwise rotating	2000	7,30
HK CBD1F5 26 F37 Z2L	26,00	200	250	123,5	61,00	anti-clockwise rotating	2000	7,30
HK CBD1F5 33 F37 Z20	33,00	200	250	128,5	63,50	clockwise rotating	2000	7,40
HK CBD1F5 33 F37 Z2L	33,00	200	250	128,5	63,50	anti-clockwise rotating	2000	7,40
HK CBD1F5 39 F37 Z20	39,00	200	250	132,5	65,50	clockwise rotating	2000	7,50
HK CBD1F5 39 F37 Z2L	39,00	200	250	132,5	65,50	anti-clockwise rotating	2000	7,50
HK CBD1F5 46 F37 Z20	46,00	200	250	138,0	68,25	clockwise rotating	2000	7,70
HK CBD1F5 46 F37 Z2L	46,00	200	250	138,0	68,25	anti-clockwise rotating	2000	7,70
HK CBD1F5 55 F39 Z20	55,00	200	250	143,0	70,25	clockwise rotating	2000	8,20
HK CBD1F5 55 F39 Z2L	55,00	200	250	143,0	70,25	anti-clockwise rotating	2000	8,20
HK CBD1F5 63 F39 Z20	63,00	200	250	149,5	74,00	clockwise rotating	2000	8,50
HK CBD1F5 63 F39 Z2L	63,00	200	250	149,5	74,00	anti-clockwise rotating	2000	8,50

VFU = conveying volume per revolution p2 = working pressure p3 = maximum pressure

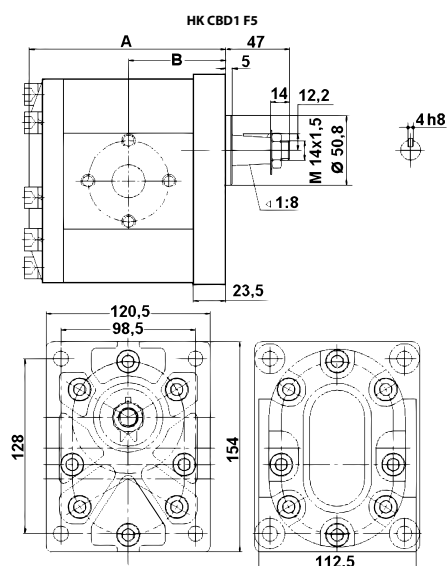

Web: <http://cat.hansa-flex.com/en/HKCBD1F5>

HK SU 2

Pump supports



Pump supports are employed on gear pumps that are driven e.g. by V-belts or chains and are thus subject to higher radial loads.

A corresponding coupling hub is required for the connection between pump and pump support. (Please order separately!)

Grease according to DIN 51502 is recommended for lubrication.

Connection only for European standard pumps.

Use: For European standard gear pumps BG2

Identification	for pump	A mm	B mm	C mm	D mm	E mm	F mm	G mm	H mm	Hub	Shaft	Weight kg
HK SU 2 C	BG 2 European Standard	88,5	71,4	113	96	49	40,0	9,5	6	HK BF 2T	Cylindrical dia. 18	1,40
HK SU 2 D	BG 2 European Standard	88,5	71,4	113	96	49	35,5	9,5	3	HK BF 2T	Conical shaft 1:8	1,40
HK SUR 2 C	BG 2 European Standard	94,0	71,4	120	96	52	46,0	9,5	6	HK BF 2T Z15	Cylindrical dia. 22	1,75
HK SUR 2 D	BG 2 European Standard	94,0	71,4	120	96	52	36,0	9,5	6	HK BF 2T Z15	Conical shaft 1:8	1,75

Hub = required coupling hub BG2/BG3 - European standard pump

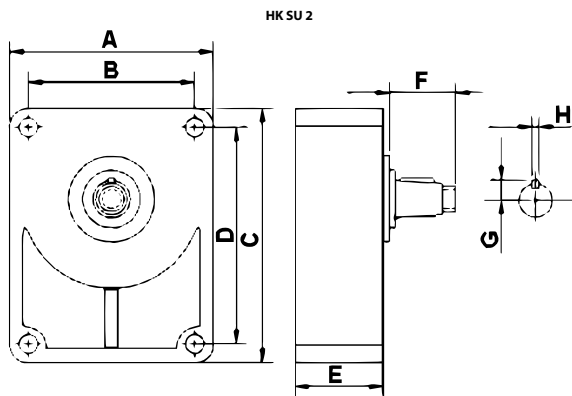

Web: <http://cat.hansa-flex.com/en/HKSU2>

Accessories:

HK BF - Coupling hub

HK SU 3

Pump supports

Pump supports are employed on gear pumps that are driven e.g. by V-belts or chains and are thus subject to higher radial loads.

A corresponding coupling hub is required for the connection between pump and pump support. (Please order separately!)

Grease according to DIN 51502 is recommended for lubrication.

Connection only for European standard pumps.

Use: For European standard gear pumps BG3



Identification	for pump	A mm	A1 mm	B mm	C mm	D mm	E mm	F mm	G mm	H mm	Hub	Shaft	Weight kg
HK SU 3 C	BG 3 European Standard	124,5	120,0	98,2	150	128	52	48,0	12,0	8	HK BF 3	Cylindrical dia. 24	2,20
HK SU 3 D	BG 3 European Standard	124,5	120,0	98,2	150	128	52	43,0	12,0	4	HK BF 3	Conical shaft 1:8	2,20

Hub = required coupling hub BG2/BG3 - European standard pump

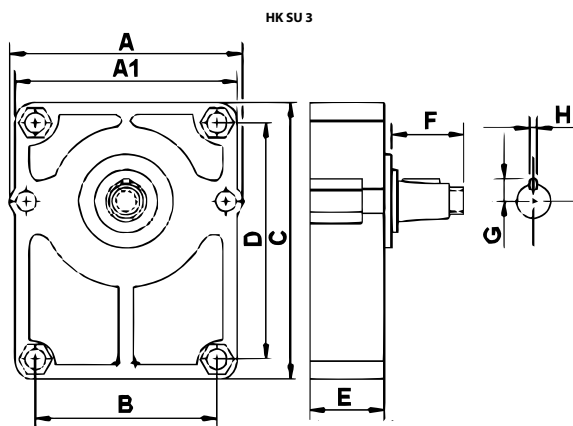

Web: <http://cat.hansa-flex.com/en/HKSU3>

Accessories:

HK BF - Coupling hub

HK BF

Coupling hub

For use in pump supports and PTO shaft gearboxes

Use: For gear pumps / pump supports

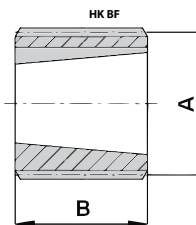

Identification	for pump	Number of teeth	Cone	A mm	B mm	Weight kg
HK BF 2T	BG 2 European Standard	14	1:8	25,0	22,5	0,03
HK BF 2T Z 15	BG 2 European Standard	15	1:8	28,0	22,0	0,06
HK BF 3	BG 3 European Standard	18	1:8	35,0	26,0	0,10

BG2/BG3 - European standard pump

Web: <http://cat.hansa-flex.com/en/HKBF>

Accessory for following products:

HK SU 2 - Pump supports

HK SU 3 - Pump supports

HK ML32 - PTO shaft gearboxes

HK ML52 - PTO shaft gearboxes

HK ML32

PTO shaft gearboxes



Material: Aluminium housing
Use: For European standard gear pumps BG2

Note: Direction of rotation:
 Pump anti-clockwise rotating - PTO shaft clockwise rotating
 Pump clockwise rotating, PTO shaft anti-clockwise rotating

Ordering information: A coupling hub BF2T is required for the connection between pump and gearbox.
 Gear unit is supplied without oil (SAE 85W-90 is recommended)

Identification	n1 max. rpm	M1 max. N-m	n2 max. rpm	M2 max. N-m	n2/n1	Connection, drive side	Weight kg
HK ML32 11 3.8	540	159	2052	42	3,8	Profile shaft - 1.3/8" - DIN 9611	4,3
HK ML32 21 3.8	540	159	2052	42	3,8	Hollow shaft - 1.3/8" - DIN 9611	4,3
HK ML32 31 3.8	540	159	2052	42	3,8	Hollow shaft with locking - 1.3/8" - DIN 9611	4,3

M1 = max. input torque M2 = max. output torque n1 = max. input speed n2 = max. output speed

Web: <http://cat.hansa-flex.com/en/HKML32>

Accessories:
 HK BF - Coupling hub

HK ML52

PTO shaft gearboxes



Material: Aluminium housing
Use: For European standard gear pumps BG3

Note: Direction of rotation:
 Pump anti-clockwise rotating - PTO shaft clockwise rotating
 Pump clockwise rotating, PTO shaft anti-clockwise rotating

Ordering information: A coupling hub BF3 is required for the connection between pump and gearbox.
 Gear unit is supplied without oil (SAE 85W-90 is recommended)

Identification	n1 max. rpm	M1 max. N-m	n2 max. rpm	M2 max. N-m	n2/n1	Connection, drive side	Weight kg
HK ML52 11 3.8	540	437	2057	115	3,8	Profile shaft - 1.3/8" - DIN 9611	7,8
HK ML52 21 3.8	540	437	2057	115	3,8	Hollow shaft - 1.3/8" - DIN 9611	7,8
HK ML52 31 3.8	540	437	2057	115	3,8	Hollow shaft with locking - 1.3/8" - DIN 9611	7,8

M1 = max. input torque M2 = max. output torque n1 = max. input speed n2 = max. output speed

Web: <http://cat.hansa-flex.com/en/HKML52>

Accessories:
 HK BF - Coupling hub

HK PVPC

PVPC axial piston pump

- Pumps with variable delivery rate
- Low noise level
- Manually adjustable pressure regulator
- Shaft with parallel key (22.22 mm for 29 cm³; 25.38 mm for 45 cm³; 31.75 mm for 73 cm³ and 90 cm³)
- Direction of rotation: clockwise rotating



Note: Version "C" = pump with manual pressure regulator
 Version "CH" = pump with manual pressure regulator and pilot pressure relief (venting), 3/2 way solenoid cartridge valve 24 VDC

Identification	VFU	n min.	n max.	p2 max.	p3 max.	SAE suction connection	SAE pressure connection	A	B	C	Ø D	E	F	H	L	Weight
								mm	mm	mm	mm	mm	mm	mm	mm	
HK PVPC C 3029 1D	29	600	3000	280	350	1.1/4"	3/4"	216	182,7	116,2	101,6	174	146	88,5	117	18
HK PVPC C 4046 1D	46	600	2600	280	350	1.1/2"	1"	248	206,0	139,5	101,6	174	146	97,5	125	24
HK PVPC C 5073 1D	73	600	2200	280	350	2"	1.1/4"	276	235,0	158,0	127,0	213	180	112,5	139	35
HK PVPC C 5090 1D	90	600	2200	250	315	2"	1.1/4"	276	235,0	158,0	127,0	213	180	112,5	139	35
HK PVPC CH 3029 1D	29	600	3000	280	350	1.1/4"	3/4"	216	182,7	116,2	101,6	174	146	88,5	144	18
HK PVPC CH 4046 1D	46	600	2600	280	350	1.1/2"	1"	248	206,0	139,5	101,6	174	146	97,5	153	24
HK PVPC CH 5073 1D	73	600	2200	280	350	2"	1.1/4"	276	235,0	158,0	127,0	213	180	112,5	166	35
HK PVPC CH 5090 1D	90	600	2200	250	315	2"	1.1/4"	276	235,0	158,0	127,0	213	180	112,5	166	35

VFU = conveying volume per revolution p2 = working pressure p3 = maximum pressure n = speed

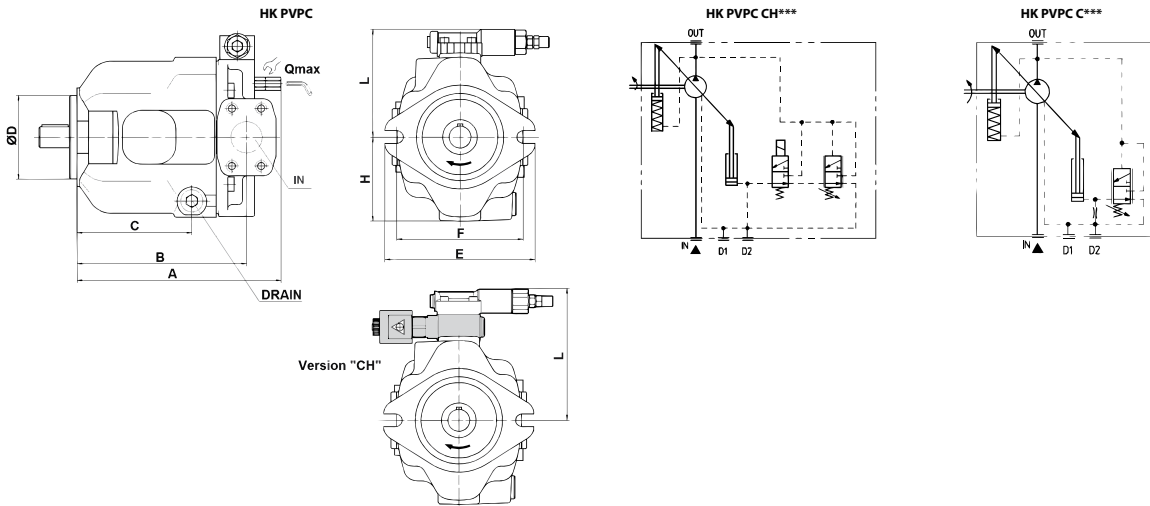

Web: <http://cat.hansa-flex.com/en/HKPVPC>

Accessories:
 HK PVPC CONTROL - Venting valve unit

HK PVPC CONTROL

Venting valve unit

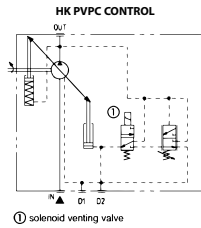
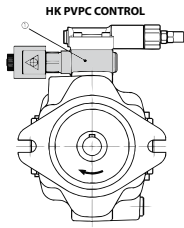

The valve consists of a 2/2-way solenoid cartridge valve 24 VDC with housing that is fitted between the pump and existing pressure regulator

Use: For pressure regulator CH for axial piston pump

Note: For retrofitting HK PVPC axial piston pumps on pressure regulator with venting function (type CH)

Identification	Weight
HK CH PVPC 2015	kg 0,5

Web: <http://cat.hansa-flex.com/en/HKPVPCCONTROL>

Accessory for following products:

HK PVPC - PVPC axial piston pump

Bent axis axial piston pump

Fixed displacement pump – hole pattern 80 x 80 – dia. 80 – shaft 8x32x16 ISO 14 – threaded fitting

Suction socket \varnothing 51.8 mm for HK PBA *** 51SF,

Suction socket \varnothing 64.5 mm for HK PBA *** 64SF

Changing rotational direction can be done by changing the setting screw and suction socket. Details can be found in the accompanying instructions.

Design: fixed displacement pump, Viton seals

Thread pressure side: G 3/4" to 63 VFU ccm, G 1" from 80 VFU ccm

Thread suction side: G 3/4" to 63 VFU ccm, G 1" from 80 VFU ccm

Scope of supply: incl. intake manifold and inspection tube



Identification	VFU cc	p2 max. bar	p3 max. bar	Speed min. rpm	Speed max. rpm	A mm	B mm	C mm	D mm	Direction of rotation	E mm	Weight kg
HK PBA 005 L 80 51 SF	5	350	400	500	3300	195	104	76	108	anti-clockwise rotating	54	8,7
HK PBA 012 L 80 51 SF	12	350	400	500	3100	195	104	76	108	anti-clockwise rotating	54	9,4
HK PBA 018 L 80 51 SF	18	350	400	500	2900	195	104	76	108	anti-clockwise rotating	54	9,4
HK PBA 025 L 80 51 SF	25	350	400	500	2700	195	104	76	108	anti-clockwise rotating	54	10,0
HK PBA 032 L 80 51 SF	32	350	400	500	2700	202	108	82	108	anti-clockwise rotating	54	11,0
HK PBA 040 L 80 51 SF	40	350	400	500	2500	202	108	82	108	anti-clockwise rotating	54	11,0
HK PBA 050 L 80 51 SF	50	350	400	500	2500	215	118	94	108	anti-clockwise rotating	54	11,5
HK PBA 056 L 80 51 SF	56	350	400	500	2300	215	118	94	108	anti-clockwise rotating	54	12,0
HK PBA 063 L 80 51 SF	63	350	400	500	2300	215	118	94	108	anti-clockwise rotating	54	12,0
HK PBA 063 L 80 51 SF	80	350	400	500	2100	242	132	104	122	anti-clockwise rotating	60	15,5
HK PBA 080 L 80 64 SF	80	350	400	500	2100	242	132	104	122	anti-clockwise rotating	60	15,5
HK PBA 108 L 80 51 SF	108	350	400	500	1900	242	132	105	122	anti-clockwise rotating	60	16,0
HK PBA 108 L 80 64 SF	108	350	400	500	1900	242	132	105	122	anti-clockwise rotating	60	16,0
HK PBA 130 LR 80 51 SF	130	350	400	500	1750	242	132	105	122	reversible	60	17,0
HK PBA 130 LR 80 64 SF	130	350	400	500	1750	242	132	105	122	reversible	60	17,0

p2 = working pressure p3 = maximum pressure

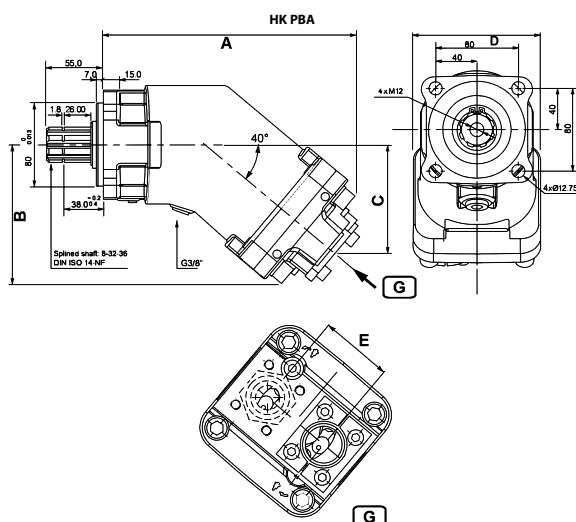

Web: <http://cat.hansa-flex.com/en/HKPBA>

HK PFE

Vane pump



Constant displacement pumps with 12 vanes in rotor insert
 Hydraulic axial backlash compensation for high-pressure operation
 Low noise level
Design: clockwise rotating

Note: Performance data at 1500 rpm with hydraulic oil with a viscosity of 24 mm²/s and 40 °C

Identification	VFU cc	Pressu- re max.		n min. rpm	n max. rpm	Q _{max} at 7		Ø shaft mm	A mm	SAE pressure connection	SAE suction connection	D mm	L mm	M mm	Q mm	Weight kg
		bar	rpm			bar max.	L/min									
HK PFE 31 016 1DT	16,5	210	800	2800	23	16	19,05	134,5		3/4"	1.1/4"	82,5	106	73,0	11,1	9,00
HK PFE 31 022 1DT	21,6	210	800	2800	30	23	19,05	134,5		3/4"	1.1/4"	82,5	106	73,0	11,1	9,00
HK PFE 31 028 1DT	28,0	210	800	2800	40	33	19,05	134,5		3/4"	1.1/4"	82,5	106	73,0	11,1	9,00
HK PFE 31 036 1DT	35,6	210	800	2800	51	43	19,05	134,5		3/4"	1.1/4"	82,5	106	73,0	11,1	9,00
HK PFE 41 045 1DT	45,0	210	800	2500	64	57	22,22	160,0		1"	1.1/2"	101,6	146	107,0	14,3	14,00
HK PFE 41 056 1DT	55,8	210	800	2500	80	72	22,22	160,0		1"	1.1/2"	101,6	146	107,0	14,3	14,00
HK PFE 41 070 1DT	69,9	210	800	2500	101	91	22,22	160,0		1"	1.1/2"	101,6	146	107,0	14,3	14,00
HK PFE 41 085 1DT	85,3	210	800	2000	124	114	22,22	189,0		1"	1.1/2"	101,6	146	107,0	14,3	14,00
HK PFE 51 150 1DT	150,0	210	800	1800	215	197	31,75	186,5		1.1/4"	2"	127,0	181	143,5	17,5	26,00
HK PFE 52 090 3DT	90,0	250	1000	2000	128	111	34,88	189,0		1.1/4"	2"	127,0	181	143,5	17,5	32,14
HK PFE 52 110 3DT	109,6	250	1000	2200	157	138	34,88	189,0		1.1/4"	2"	127,0	181	143,5	17,5	32,14
HK PFE 52 129 3DT	129,2	250	1000	2200	186	163	34,88	189,0		1.1/4"	2"	127,0	181	143,5	17,5	32,14

VFU = conveying volume per revolution n = speed

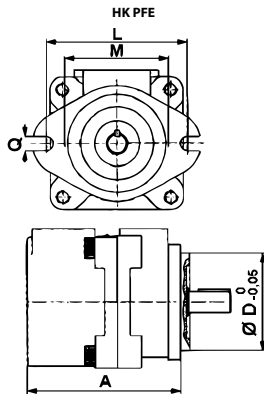

Web: <http://cat.hansa-flex.com/en/HKPFE>

HK 9RD 02 BG1

Gear flow divider, size 1 9RD 2-way

This flow divider is used to supply two independent hydraulic circuits with just one pump

Division error approx. 3%

Configuration of gear flow dividers: $q_i = Q/z * 1000/n$

q_i = displacement/section [cm³]; Q = total intake volumetric flow [l/min]; z = no. of sections; n = rotating speed [rpm]

Design: without central phase compensation valves, internal leak oil discharge

Rotational speed range: 1200 - 2700 U/min

Pressure difference: max. 30 bar (between the sections)

Recommended speed: 1800 - 2000 rpm

Note: Before commissioning the system, the first running-in of the gear flow divider should be under no load.

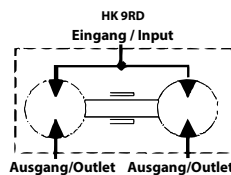

Identification	Intake volume per section cc	p1 max. bar	p2 max. bar	Flow per element min. L/min	Flow per element max. L/min	Flow per element L/min	A mm	Li mm	Weight kg
HK 9RD 02 18	1,70	220	270	2,00	9,50	4,00	44	228	2,20
HK 9RD 02 20	2,20	220	270	2,50	13,00	5,00	46	232	2,25
HK 9RD 02 21	2,60	220	270	3,00	16,00	6,00	48	236	2,30
HK 9RD 02 23	3,20	220	270	3,50	19,00	7,00	50	240	2,40
HK 9RD 02 25	3,80	200	240	4,50	22,50	8,00	52	244	2,50

p1 = max. working pressure p2 = max. peak pressure

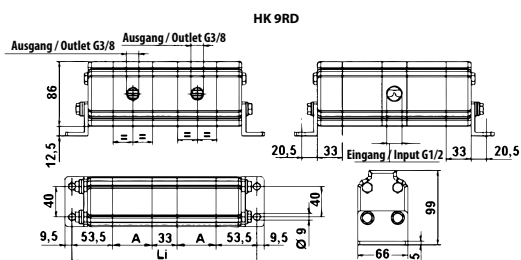

Web: <http://cat.hansa-flex.com/en/HK9RD02BG1>

HK 9RS 02 BG1

Gear flow divider, size 1 9RS 2-way

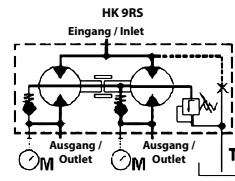

This flow divider is used to supply two independent hydraulic circuits with just one pump
 Division error approx. 3%
 Equal pressure setting for all sections
 Valves settable from 70-210 bar, other setting ranges on request
 Modification to internal leak oil discharge possible - For this, remove the cylinder head screw in port T and close off the port with G1/2" blind plug (modification recommended only after consultation!)
 Configuration of gear flow dividers: $q_i = Q/z * 1000/n$
 q_i = displacement/section [cm³]; Q = total intake volumetric flow [l/min]; z = no. of sections; n = rotating speed [rpm]

Design: with central phase compensation valve, external leak oil discharge, Adjustment range DBV: 70-210 bar

Rotational speed range: 1200 - 2700 U/min
Pressure difference: max. 30 bar (between the sections)
Recommended speed: 1800 - 2000 rpm

Note: Before commissioning the system, the first running-in of the gear flow divider should be under no load.

Identification	Intake volume per section		p1 max.	p2 max.	Flow per element min.		Flow per element max.		Flow per element	A	Li	Weight
	cc	bar			bar	L/min	L/min	L/min				
HK 9RS 02 D 18	1,70	220	270	2,00	9,50	4,00	44	228	2,20			
HK 9RS 02 D 20	2,20	220	270	2,50	13,00	5,00	46	232	2,25			
HK 9RS 02 D 21	2,60	220	270	3,00	16,00	6,00	48	236	2,35			
HK 9RS 02 D 23	3,20	220	270	3,50	19,00	7,00	50	240	2,45			
HK 9RS 02 D 25	3,80	200	240	4,50	22,50	8,00	52	244	2,55			

p1 = max. working pressure p2 = max. peak pressure

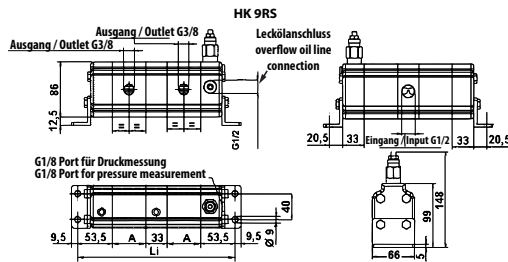

Web: <http://cat.hansa-flex.com/en/HK9RS02BG1>

HK 9RV 02 BG1

Gear flow divider, size 1 9RV 2-way

This flow divider is used to supply two independent hydraulic circuits with just one pump

Division error approx. 3%

Different pressure settings for each section possible

Valves settable from 7-210 bar, other setting ranges on request

Modification to internal leak oil discharge possible - For this, close off port T with G1/2" blind plug (modification recommended only after consultation!)

Configuration of gear flow dividers: $q_i = Q/z * 1000/n$

q_i = displacement/section [cm³]; Q = total intake volumetric flow [l/min]; z = no. of sections; n = rotating speed [rpm]

Design: with one phase compensation valve and anti-cavitation valve per section, external leak oil discharge, Adjustment range DBV: 7-210 bar

Rotational speed range: 1200 - 2700 U/min

Pressure difference: max. 30 bar (between the sections)

Recommended speed: 1800 - 2000 rpm

Note: Before commissioning the system, the first running-in of the gear flow divider should be under no load.

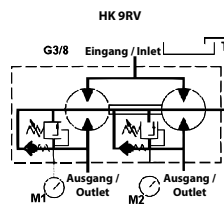

Identification	Intake volume per section cc	p1 max. p2 max.		Flow per element min. Flow per element max.		Flow per element L/min	A mm	Li mm	Weight kg
		bar	bar	L/min	L/min				
HK 9RV 02 A 18	1,70	220	270	2,00	9,50	4,00	44	228	2,25
HK 9RV 02 A 20	2,20	220	270	2,50	13,00	5,00	46	232	2,30
HK 9RV 02 A 21	2,60	220	270	3,00	16,00	6,00	48	236	2,35
HK 9RV 02 A 23	3,20	220	270	3,50	19,00	7,00	50	240	2,45
HK 9RV 02 A 25	3,80	200	240	4,50	22,50	8,00	52	244	2,55

p1 = max. working pressure p2 = max. peak pressure

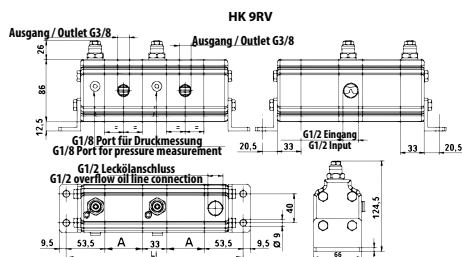

Web: <http://cat.hansa-flex.com/en/HK9RV02BG1>

HK 9RD 04 BG1

Gear flow divider, size 1 9RD 4-way

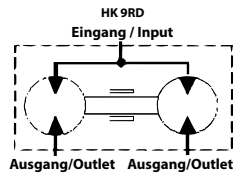

This flow divider is used to supply four independent hydraulic circuits with just one pump

Division error approx. 3%

Configuration of gear flow dividers: $q_i = Q/z * 1000/n$

q_i = displacement/section [cm³]; Q = total intake volumetric flow [l/min]; z = no. of sections; n = rotating speed [rpm]

Design: without central phase compensation valves, internal leak oil discharge

Rotational speed range: 1200 - 2700 U/min

Pressure difference: max. 30 bar (between the sections)

Recommended speed: 1800 - 2000 rpm

Note: Before commissioning the system, the first running-in of the gear flow divider should be under no load.

Diagrams and circuit diagrams essentially valid as schematic diagrams also for 4-way flow dividers.

Identification	Intake volume per section cc	p1 max. bar	p2 max. bar	Flow per element min. L/min	Flow per element max. L/min	Flow per element L/min	A mm	Li mm	Weight kg
HK 9RD 04 18	1,70	220	270	2,00	9,50	4,00	44	382	4,45
HK 9RD 04 20	2,20	220	270	2,50	13,00	5,00	46	390	4,50
HK 9RD 04 21	2,60	220	270	3,00	16,00	6,00	48	398	4,65
HK 9RD 04 23	3,20	220	270	3,50	19,00	7,00	50	406	4,80
HK 9RD 04 25	3,80	200	240	4,50	22,50	8,00	52	414	6,00

p1 = max. working pressure p2 = max. peak pressure

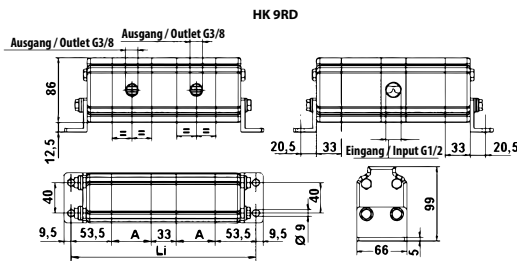

Web: <http://cat.hansa-flex.com/en/HK9RD04BG1>

HK 9RS 04 BG1

Gear flow divider, size 1 9RS 4-way

This flow divider is used to supply four independent hydraulic circuits with just one pump
 Division error approx. 3%
 Equal pressure setting for all sections
 Valves settable from 70-210 bar, other setting ranges on request
 Modification to internal leak oil discharge possible - For this, remove the cylinder head screw in port T and close off the port with G1/2" blind plug (modification recommended only after consultation!)
 Configuration of gear flow dividers: $q_i = Q/z * 1000/n$
 q_i = displacement/section [cm³]; Q = total intake volumetric flow [l/min]; z = no. of sections; n = rotating speed [rpm]

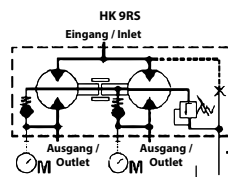

Design: with central phase compensation valve, external leak oil discharge, Adjustment range DBV: 70-210 bar

Rotational speed range: 1200 - 2700 U/min
Pressure difference: max. 30 bar (between the sections)
Recommended speed: 1800 - 2000 rpm

Note: Before commissioning the system, the first running-in of the gear flow divider should be under no load.

Diagrams and circuit diagrams essentially valid as schematic diagrams also for 4-way flow dividers.

Identification	Intake volume per section cc	p1 max.	p2 max.	Flow per element min.	Flow per element max.	Flow per element	A mm	Li mm	Weight kg
		bar	bar	L/min	L/min	L/min			
HK 9RS 04 D 18	1,70	220	270	2,00	9,50	4,00	44	382	5,50
HK 9RS 04 D 20	2,20	220	270	2,50	13,00	5,00	46	390	4,55
HK 9RS 04 D 21	2,60	220	270	3,00	16,00	6,00	48	398	4,70
HK 9RS 04 D 23	3,20	220	270	3,50	19,00	7,00	50	406	4,85
HK 9RS 04 D 25	3,80	200	240	4,50	22,50	8,00	52	414	4,95

p1 = max. working pressure p2 = max. peak pressure

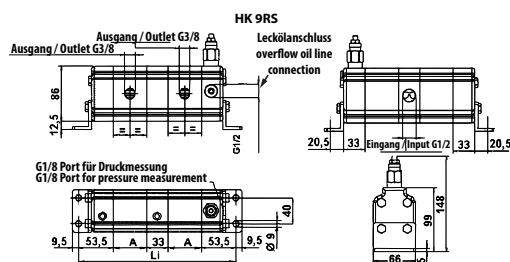

Web: <http://cat.hansa-flex.com/en/HK9RS04BG1>

HK 9RV 04 BG1

Gear flow divider, size 1 9RV 4-way

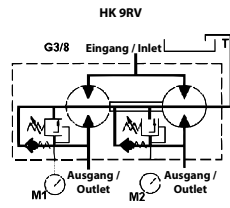

This flow divider is used to supply four independent hydraulic circuits with just one pump
 Division error approx. 3%
 Different pressure settings for each section possible
 Valves settable from 7-210 bar, other setting ranges on request
 Modification to internal leak oil discharge possible - For this, close off port T with G1/2" blind plug (modification recommended only after consultation!)
 Configuration of gear flow dividers: $q_i = Q/z * 1000/n$
 q_i = displacement/section [cm³]; Q = total intake volumetric flow [l/min]; z = no. of sections; n = rotating speed [rpm]

Design: with one phase compensation valve and anti-cavitation valve per section, external leak oil discharge, Adjustment range DBV: 7-210 bar

Rotational speed range: 1200 - 2700 U/min

Pressure difference: max. 30 bar (between the sections)

Recommended speed: 1800 - 2000 rpm

Note: Before commissioning the system, the first running-in of the gear flow divider should be under no load.

Diagrams and circuit diagrams essentially valid as schematic diagrams also for 4-way flow dividers.

Identification	Intake volume per section cc	p1 max.	p2 max.	Flow per element min. L/min	Flow per element max. L/min	Flow per element L/min	A mm	Li mm	Weight kg
		bar	bar						
HK 9RV 04 A 18	1,70	220	270	2,00	9,50	4,00	44	382	4,50
HK 9RV 04 A 20	2,20	220	270	2,50	13,00	5,00	46	390	4,55
HK 9RV 04 A 21	2,60	220	270	3,00	16,00	6,00	48	398	4,70
HK 9RV 04 A 23	3,20	220	270	3,50	19,00	7,00	50	406	4,85
HK 9RV 04 A 25	3,80	200	240	4,50	22,50	8,00	52	414	4,95

p1 = max. working pressure p2 = max. peak pressure

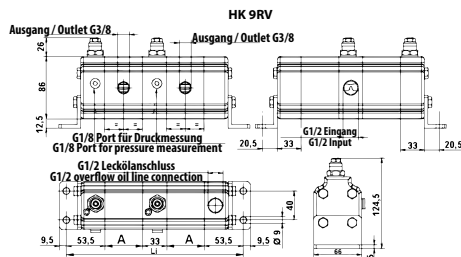

Web: <http://cat.hansa-flex.com/en/HK9RV04BG1>

HK 92RD 02 BG2

Gear flow divider, size 2 92RD 2-way

This flow divider is used to supply four independent hydraulic circuits with just one pump

Division error approx. 3%

This flow divider is used to supply two independent hydraulic circuits with just one pump

Configuration of gear flow dividers: $q_i = Q/z * 1000/n$

q_i = displacement/section [cm³]; Q = total intake volumetric flow [l/min]; z = no. of sections; n = rotating speed [rpm]

Design: without central phase compensation valves, internal leak oil discharge

Rotational speed range: 1200 - 2500 U/min

Pressure difference: max. 30 bar (between the sections)

Recommended speed: 1800 - 2000 rpm

Note: Before commissioning the system, the first running-in of the gear flow divider should be under no load.

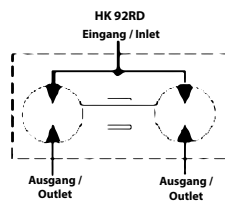

1

Identification	Intake volume per section cc	p1 max. bar	p2 max. bar	Flow per element min. L/min	Flow per element max. L/min	Flow per element L/min	A mm	Li mm	Weight kg
HK 92RD 02 41	4,00	210	260	4,80	10,00	7,60	47	218	4,8
HK 92RD 02 43	6,00	210	260	7,20	15,00	10,80	50	224	5,0
HK 92RD 02 45	9,00	210	260	10,80	22,50	15,10	54	232	5,3
HK 92RD 02 47	11,00	210	260	13,20	27,50	19,40	58	240	5,5
HK 92RD 02 49	14,00	200	230	16,80	35,00	25,90	64	252	5,7

p1 = max. working pressure p2 = max. peak pressure

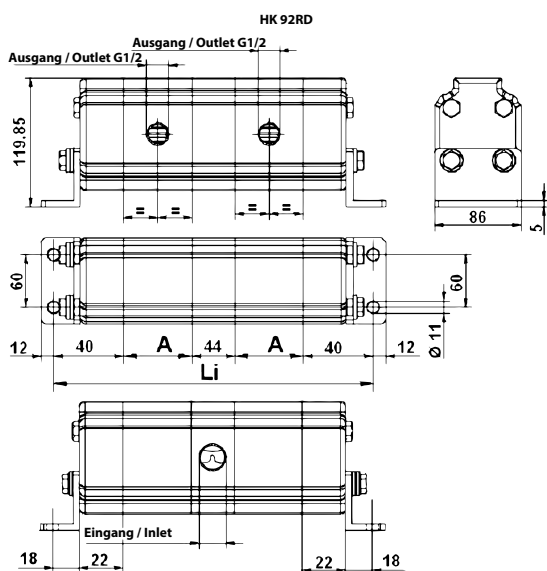

Web: <http://cat.hansa-flex.com/en/HK92RD02BG2>

HK 92RV 02 BG2

Gear flow divider, size 2 92RV 2-way

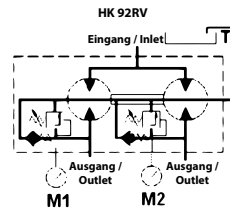

This flow divider is used to supply two independent hydraulic circuits with just one pump
 Division error approx. 3%
 Different pressure settings for each section possible
 Valves settable from 70-210 bar, other setting ranges on request
 Modification to internal leak oil discharge possible - For this, close off port T with G1/2" blind plug (modification recommended only after consultation!)
 After modification to internal leak oil discharge, the integrated suction valves are decommissioned
 Configuration of gear flow dividers: $q_i = Q/z * 1000/n$
 q_i = displacement/section [cm³]; Q = total intake volumetric flow [l/min]; z = no. of sections; n = rotating speed [rpm]

Design: with one phase compensation valve and anti-cavitation valve per section, external leak oil discharge, Adjustment range DBV: 70-210 bar

Rotational speed range: 1200 - 2500 U/min

Pressure difference: max. 30 bar (between the sections)

Recommended speed: 1800 - 2000 rpm

Note: Before commissioning the system, the first running-in of the gear flow divider should be under no load.

Identification	Intake volume per section cc	p1 max. p2 max.		Flow per element min.		Flow per element max.		Flow per element L/min	A mm	Li mm	Weight kg
		bar	bar	L/min	L/min	L/min	L/min				
HK 92RV 02 B 41	4,00	210	260	4,80	10,00	7,60	47	262	5,8		
HK 92RV 02 B 43	6,00	210	260	7,20	15,00	10,80	50	268	6,1		
HK 92RV 02 B 45	9,00	210	260	10,80	22,50	15,10	54	276	6,6		
HK 92RV 02 B 47	11,00	210	260	13,20	27,50	19,40	58	284	7,0		
HK 92RV 02 B 49	14,00	200	230	16,80	35,00	25,90	64	296	7,4		

p1 = max. working pressure p2 = max. peak pressure

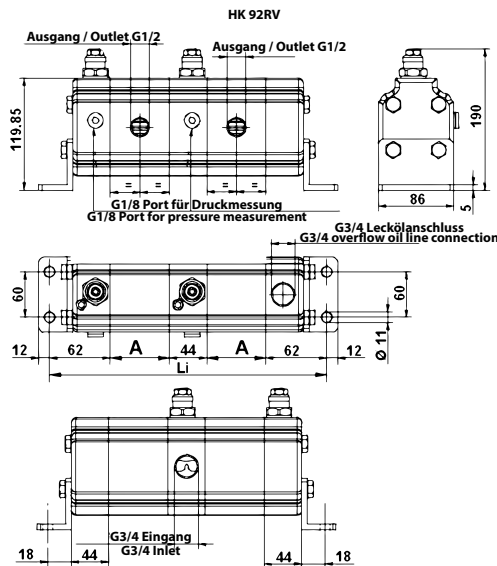

Web: <http://cat.hansa-flex.com/en/HK92RV02BG2>

HK 92RD 04 BG2

Gear flow divider, size 2 92RD 4-way

This flow divider is used to supply four independent hydraulic circuits with just one pump

Division error approx. 3%

This flow divider is used to supply two independent hydraulic circuits with just one pump

Configuration of gear flow dividers: $q_i = Q/z * 1000/n$

q_i = displacement/section [cm³]; Q = total intake volumetric flow [l/min]; z = no. of sections; n = rotating speed [rpm]

Design: without central phase compensation valves, internal leak oil discharge

Rotational speed range: 1200 - 2500 U/min

Pressure difference: max. 30 bar (between the sections)

Recommended speed: 1800 - 2000 rpm

Note: Before commissioning the system, the first running-in of the gear flow divider should be under no load.

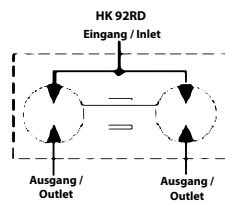

Diagrams and circuit diagrams essentially valid as schematic diagrams also for 4-way flow dividers.

Identification	Intake volume per section	p1 max. bar	p2 max. bar	Flow per element min.	Flow per element max.	Flow per element	A mm	Li mm	Weight kg
	cc			L/min	L/min	L/min			
HK 92RD 04 41	4,00	210	260	4,80	10,00	7,60	47	400	9,5
HK 92RD 04 43	6,00	210	260	7,20	15,00	10,80	50	412	9,9
HK 92RD 04 45	9,00	210	260	10,80	22,50	15,10	54	428	10,3
HK 92RD 04 47	11,00	210	260	13,20	27,50	19,40	58	444	10,8
HK 92RD 04 49	14,00	200	230	16,80	35,00	25,90	64	468	11,5

p1 = max. working pressure p2 = max. peak pressure

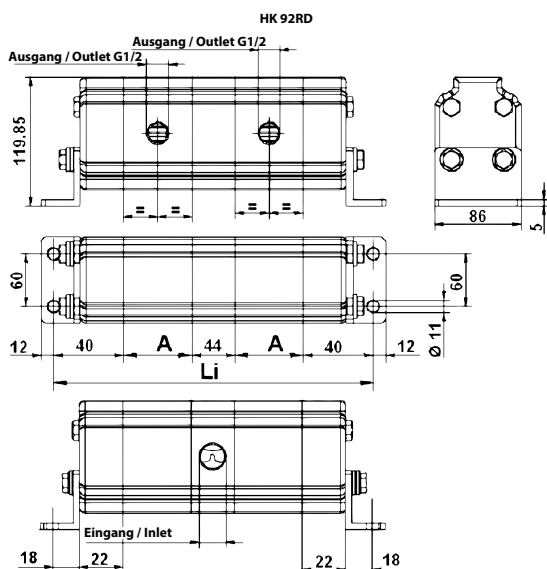

Web: <http://cat.hansa-flex.com/en/HK92RD04BG2>

HK 92RV 04 BG2

Gear flow divider, size 2 92RV 4-way

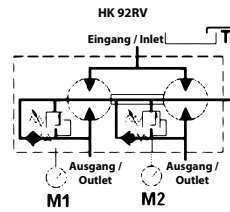

This flow divider is used to supply four independent hydraulic circuits with just one pump
 Division error approx. 3%
 Different pressure settings for each section possible
 Valves settable from 70-210 bar, other setting ranges on request
 Modification to internal leak oil discharge possible - For this, close off port T with G1/2" blind plug (modification recommended only after consultation!)
 After modification to internal leak oil discharge, the integrated suction valves are decommissioned
 Configuration of gear flow dividers: $q_i = Q/z * 1000/n$
 q_i = displacement/section [cm³]; Q = total intake volumetric flow [l/min]; z = no. of sections; n = rotating speed [rpm]

Design: with one phase compensation valve and anti-cavitation valve per section, external leak oil discharge, Adjustment range DBV: 70-210 bar

Rotational speed range: 1200 - 2500 U/min

Pressure difference: max. 30 bar (between the sections)

Recommended speed: 1800 - 2000 rpm

Note: Before commissioning the system, the first running-in of the gear flow divider should be under no load.

Diagrams and circuit diagrams essentially valid as schematic diagrams also for 4-way flow dividers.

Identification	Intake volume per section cc	p1 max. bar	p2 max. bar	Flow per element min. L/min	Flow per element max. L/min	Flow per element L/min	A mm	Li mm	Weight kg
HK 92RV 04 B 41	4,00	210	260	4,80	10,00	7,60	47	444	11,1
HK 92RV 04 B 43	6,00	210	260	7,20	15,00	10,80	50	456	11,8
HK 92RV 04 B 45	9,00	210	260	10,80	22,50	15,10	54	472	12,4
HK 92RV 04 B 47	11,00	210	260	13,20	27,50	19,40	58	488	13,0
HK 92RV 04 B 49	14,00	200	230	16,80	35,00	25,90	64	512	13,7

p1 = max. working pressure p2 = max. peak pressure

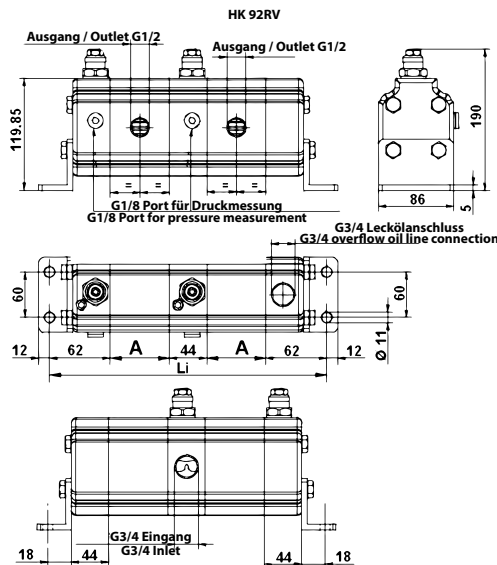

Web: <http://cat.hansa-flex.com/en/HK92RV04BG2>

EPMS geroller motor

Connection: Oil connectors: A + B = G 1/2"; leak oil = G 1/4"
Design: Standard variant, Type "C" with standard seal, Four hole flange bolt circle 106,4,
 Shaft Ø 32mm
**Intake and return pressure
 with leak oil line max.:** 210 bar



Note: It is generally recommended that the leak oil line is connected!

Identification	Flow rate max.	Displacement	Speed min.	Speed max.	Torque max.	Pressure drop max.	Pmax. at 0-100 rpm	Pmax. at 100-300 rpm	Pmax. at >300 rpm	L	Weight
	L/min	cc	rpm	rpm	N-m	bar	bar	bar	bar	mm	kg
HK EPMS 080 C	65	80,5	10	810	200	175	100	50	20	166	9,8
HK EPMS 100 C	75	100,0	10	750	290	175	100	50	20	169	10,0
HK EPMS 125 C	75	125,7	8	600	370	175	100	50	20	174	10,3
HK EPMS 160 C	75	159,7	8	470	460	150	100	50	20	180	10,7
HK EPMS 200 C	75	200,0	8	375	460	140	100	50	20	187	11,1
HK EPMS 250 C	75	250,0	8	300	500	125	100	50		195	11,6
HK EPMS 315 C	75	314,9	8	240	540	120	100	50		207	12,3
HK EPMS 400 C	75	397,0	8	185	580	100	100	50		221	13,2

max. pressure on shaft seal (without leak oil line) or pressure in leak oil line Values for torque and pressure drop apply for continuous operation pmax = max. pressure

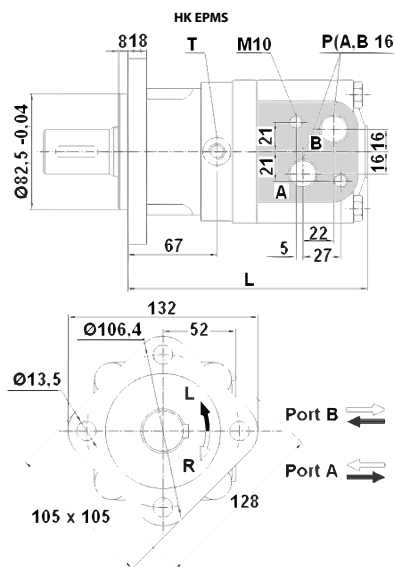

Web: <http://cat.hansa-flex.com/en/HKEPMS>

Spare parts:

HK EP DS - Seal kit for hydraulic planetary motor

Accessories:

HK V0 590 - Shock valve

HK HM BMS

BMS CN geroller motor



Connection: Oil connectors: A + B = G 1/2"; leak oil = G 1/4"
Design: Economy variant, always connect drain line, Four hole flange bolt circle 106,4, Shaft Ø 32mm
Intake and return pressure with leak oil line max.: 210 bar

Note: It is generally recommended that the leak oil line is connected!

Identification	Flow rate max. L/min	Displacement cc	Speed min. rpm	Speed max. rpm	Torque max. N-m	Pressure drop max. bar	Pmax. at	Pmax. at	Pmax. at	L mm	Weight kg
							0-100 rpm bar	100-300 rpm bar	>300 rpm bar		
HK HM BMS 080	65	80,5	10	810	194	175	100	50	20	167	9,8
HK HM BMS 100	75	100,5	10	750	242	175	100	50	20	170	10,0
HK HM BMS 125	75	126,3	8	600	303	175	100	50	20	175	10,3
HK HM BMS 160	75	160,8	8	470	358	160	100	50	20	181	10,7
HK HM BMS 200	75	200,9	8	375	438	160	100	50	20	188	11,1
HK HM BMS 250	75	252,6	8	300	440	125	100	50		197	11,6
HK HM BMS 315	75	321,5	8	240	530	125	100	50		208	12,3
HK HM BMS 400	75	401,9	8	180	562	100	100	50		222	13,2

max. pressure on shaft seal (without leak oil line) or pressure in leak oil line Values for torque and pressure drop apply for continuous operation pmax = max. pressure

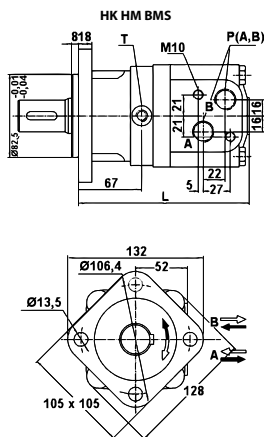

Web: <http://cat.hansa-flex.com/en/HKHM BMS>

Spare parts:

HK HM BM DS - Seal kit for hydraulic planetary motor CN

Accessories:

HK V0 590 - Shock valve

EPMT geroller motor

Connection: Oil fittings: A + B = G 3/4"; leak oil = G 1/4"
Design: Standard variant, Type "C" with standard seal, Four hole flange bolt circle 160, Shaft Ø 40mm, length 79mm
Intake and return pressure with leak oil line max.: 210 bar



Note: It is generally recommended that the leak oil line is connected!

Identification	Flow rate max.	Displacement	Speed min.	Speed max.	Torque max.	Pressure drop max.	Pmax. at 0-100 rpm	Pmax. at 100-300 rpm	Pmax. at >300 rpm	L	Weight
	L/min	cc	rpm	rpm	N-m	bar	bar	bar	bar	mm	kg
HK EPMT 160 C	100	161,1	10	625	470	200	75	40	20	190	20,0
HK EPMT 200 C	125	201,4	10	625	590	200	75	40	20	195	22,5
HK EPMT 250 C	125	251,8	10	500	730	200	75	40	20	201	21,5
HK EPMT 315 C	125	326,3	10	380	950	200	75	40	20	211	22,0
HK EPMT 400 C	125	410,9	10	305	1080	180	75	40	20	221	23,0
HK EPMT 500 C	125	523,6	10	240	1220	160	75	40	20	235	24,0

max. pressure on shaft seal (without leak oil line) or pressure in leak oil line Values for torque and pressure drop apply for continuous operation pmax = max. pressure

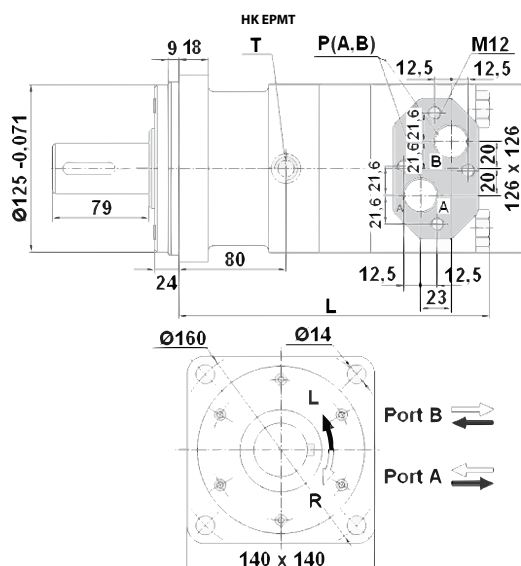

Web: <http://cat.hansa-flex.com/en/HKEPMT>

Spare parts:
 HK EP DS - Seal kit for hydraulic planetary motor

Accessories:
 HK V0 590 - Shock valve

HK HM BMT

BMT CN geroller motor



Connection: Oil fittings: A + B = G 3/4"; leak oil = G 1/4"
Design: Economy variant / short shaft, always connect drain line, Four hole flange bolt circle 160, Shaft Ø 40mm, length 60mm
Intake and return pressure with leak oil line max.: 210 bar

Note: It is generally recommended that the leak oil line is connected!

Identification	Flow rate max. L/min	Displacement cc	Speed min. rpm	Speed max. rpm	Torque max. N-m	Pressure drop max. bar	Pmax. at	Pmax. at	Pmax. at	L mm	Weight kg
							0-100 rpm bar	100-300 rpm bar	>300 rpm bar		
HK HM BMT 160	100	158,8	10	625	450	200	75	40	20	210	20,3
HK HM BMT 200	125	200,8	10	625	560	200	75	40	20	215	20,8
HK HM BMT 250	125	252,2	10	500	710	200	75	40	20	220	21,4
HK HM BMT 315	125	317,5	10	280	900	200	75	40	20	227	22,4
HK HM BMT 400	125	401,6	10	305	1000	180	75	40	20	236	23,0
HK HM BMT 500	125	535,5	10	240	1120	160	75	40	20	255	24,0

max. pressure on shaft seal (without leak oil line) or pressure in leak oil line Values for torque and pressure drop apply for continuous operation pmax = max. pressure

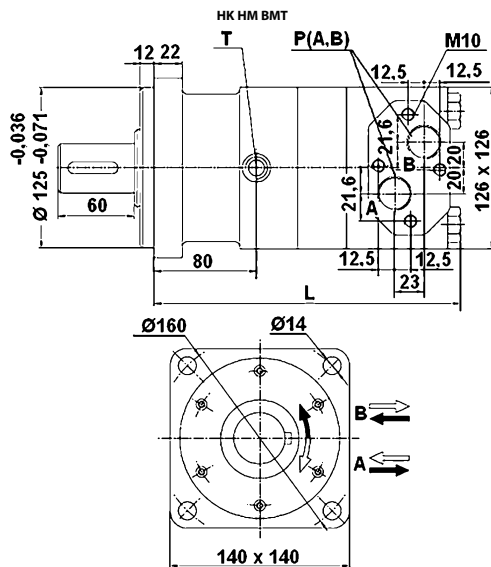

Web: <http://cat.hansa-flex.com/en/HKHMBMT>

Spare parts:
 HK HM BM DS - Seal kit for hydraulic planetary motor CN

Accessories:
 HK V0 590 - Shock valve

HK EPRM CD
EPRM geroller motor

Connection: Oil fittings: A + B = G 1/2"; leak oil = G 1/4"
Design: Standard variant, Type "CD" with high-pressure gasket, two hole flange bolt circle 106.4, Shaft \varnothing 25mm
Intake and return pressure with leak oil line max.: 175 bar



Identification	Flow rate max.	Displacement	Speed min.	Speed max.	Torque max.	Pressure drop max.	Pmax. at				L	Weight
							0-100 rpm	100-300 rpm	300-600 rpm	>600 rpm		
	L/min	cc	rpm	rpm	N-m	bar	rpm bar	rpm bar	rpm bar	rpm bar	mm	kg
HK EPRM 050 CD	40	51,5	10	775	100	140	150	75	50	20	138	6,8
HK EPRM 080 CD	60	80,3	10	750	195	175	150	75	50	20	143	6,9
HK EPRM 100 CD	60	99,8	10	600	240	175	150	75	50		147	7,2
HK EPRM 125 CD	60	125,7	10	475	300	175	150	75	50		151	7,3
HK EPRM 160 CD	60	159,6	10	375	390	175	150	75	50		157	7,5
HK EPRM 200 CD	60	199,8	10	300	385	140	150	75			164	8,0
HK EPRM 250 CD	60	250,1	10	240	390	110	150	75			173	8,4
HK EPRM 315 CD	60	315,7	10	190	390	90	150	75			184	9,1
HK EPRM 400 CD	60	397,0	10	150	380	70	150	75			198	9,8

max. pressure on shaft seal (without leak oil line) or pressure in leak oil line pressure Values for torque and pressure drop apply for continuous operation pmax = max. pressure

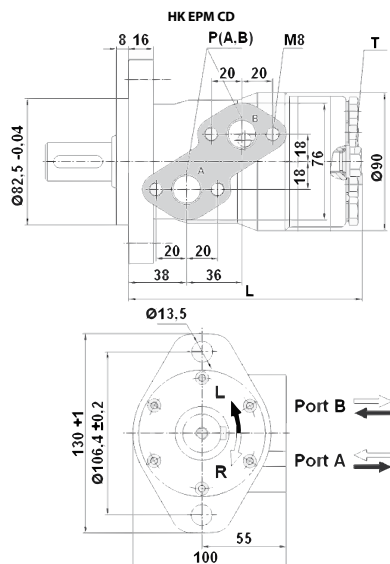

Web: <http://cat.hansa-flex.com/en/HKEPRMCD>

Spare parts:
 HK EP DS - Seal kit for hydraulic planetary motor

Accessories:
 HK V0 590 - Shock valve

HK HM BMR HD

BMR HD CN geroller motor



Connection: Oil fittings: A + B = G 1/2"; leak oil = M14x1.5
Design: Economy variant, Type "HD" with high-pressure gasket, two hole flange bolt circle 106.4, Shaft Ø 25mm
Intake and return pressure with leak oil line max.: 175 bar

1

Identification	Flow rate max. L/min	Displacement cc	Speed min. rpm	Speed max. rpm	Torque max. N-m	Pressure drop max. bar	Pmax. at				L mm	Weight kg
							0-100 rpm	100-300 rpm	300-600 rpm	>600 rpm		
HK HM BMR 050 HD	40	51,7	10	775	93	140	150	75	50	20	139	6,5
HK HM BMR 080 HD	60	80,5	10	750	152	140	150	75	50	20	144	6,9
HK HM BMR 100 HD	60	100,5	10	600	194	140	150	75	50	20	148	7,0
HK HM BMR 125 HD	60	126,3	10	475	237	140	150	75	50	20	152	7,3
HK HM BMR 160 HD	60	160,8	10	375	300	140	150	75	50	20	158	7,5
HK HM BMR 200 HD	60	200,9	10	300	370	140	150	75	50	20	165	8,0
HK HM BMR 250 HD	60	252,6	10	240	370	110	150	75			174	8,5
HK HM BMR 315 HD	60	321,5	10	190	370	90	150	75			186	9,0
HK HM BMR 400 HD	60	401,9	10	160	370	70	150	75			200	11,0

max. pressure on shaft seal (without leak oil line) or pressure in leak oil line Values for torque and pressure drop apply for continuous operation pmax = max. pressure

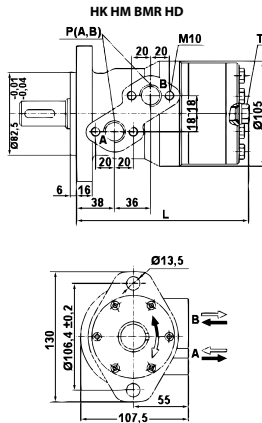

Web: <http://cat.hansa-flex.com/en/HKHMBMRHD>

Spare parts:

HK HM BM DS - Seal kit for hydraulic planetary motor CN

Accessories:

HK V0 590 - Shock valve

HK EPMM C

EPMM gerotor motor

Connection: Oil fittings at rear: A + B = G 3/8"; leak oil = G 1/4"
Design: Standard variant, Type "C" with standard seal,
 Shaft Ø 16mm
**Intake and return pressure
 with leak oil line max.:** 140 bar

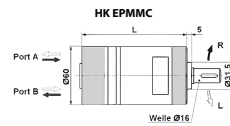

Note: It is generally recommended that the leak oil line is connected!

Identification	Flow rate max. L/min	Displacement cc	Speed min. rpm	Speed max. rpm	Torque max. N-m	Pressure drop max. bar	Pmax. at				L mm	Weight kg
							0-100 rpm bar	100-300 rpm bar	300-600 rpm bar	>600 rpm bar		
HK EPMM 008 C	16	8,2	50	1950	11	100	140	100	40	20	104	1,9
HK EPMM 012 C	20	12,9	40	1550	16	100	140	100	40	20	106	2,0
HK EPMM 020 C	20	20,0	30	1000	25	100	140	100	40	20	109	2,1
HK EPMM 032 C	20	31,8	30	630	40	100	140	100	40		114	2,2
HK EPMM 040 C	20	40,0	25	500	41	80	140	100	40		118	2,3
HK EPMM 050 C	20	50,0	20	400	45	70	140	100			122	2,4

max. pressure on shaft seal (without leak oil line) or pressure in leak oil line Values for torque and pressure drop apply for continuous operation

Web: <http://cat.hansa-flex.com/en/HKEPMMC>

Spare parts:

HK EP DS - Seal kit for hydraulic planetary motor

Accessories:

HK EPMM F - Flange for gerotor motor

HK EPM CD

EPM gerotor motor



Connection:

Oil connectors: A + B = G 1/2"; leak oil = G 1/4"

Design:

Standard variant, Type "CD" with high-pressure gasket, two hole flange bolt circle 106.4, Shaft Ø 25mm

Intake and return pressure

with leak oil line max.: 175 bar

Identification	Flow rate max. L/min	Displacement cc	Speed min. rpm	Speed max. rpm	Torque max. N-m	Pressure drop max. bar	Pmax. at				L mm	Weight kg
							0-100 rpm	100-300 rpm	300-600 rpm	>600 rpm		
HK EPM 025 CD	40	25,0	20	1600	33	100	150	75	50	20	133	5,6
HK EPM 032 CD	50	32,0	15	1560	43	100	150	75	50	20	135	5,6
HK EPM 040 CD	60	39,7	10	1510	62	120	150	75	50	20	135	5,8
HK EPM 050 CD	60	49,5	10	1210	94	140	150	75	50	20	136	5,8
HK EPM 080 CD	60	79,2	10	755	150	140	150	75	50	20	140	5,9
HK EPM 100 CD	60	99,0	10	605	190	140	150	75	50	20	141	6,1
HK EPM 125 CD	60	123,8	10	486	230	140	150	75	50		145	6,2
HK EPM 160 CD	60	158,4	10	378	310	140	150	75	50		150	6,4
HK EPM 200 CD	60	198,0	10	303	360	140	150	75	50		155	6,6
HK EPM 250 CD	60	247,5	10	242	380	110	150	75			162	6,8
HK EPM 315 CD	60	316,8	10	190	380	90	150	75			171	7,1
HK EPM 400 CD	60	396,0	10	150	380	70	150	75			182	7,6
HK EPM 500 CD	60	495,0	10	120	390	60	150	75			195	9,0
HK EPM 630 CD	60	623,0	10	95	440	55	150				213	9,5

max. pressure on shaft seal (without leak oil line) or pressure in leak oil line Values for torque and pressure drop apply for continuous operation

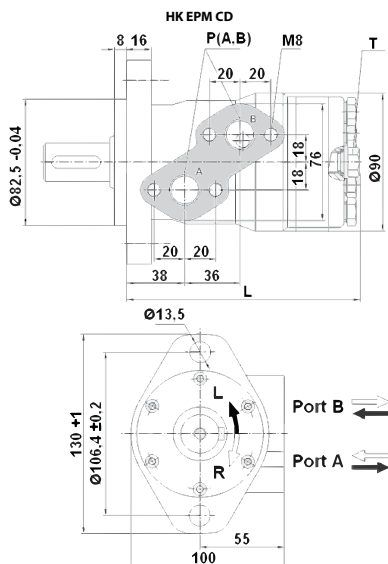

Web: <http://cat.hansa-flex.com/en/HKEPMCD>

Spare parts:

HK EP DS - Seal kit for hydraulic planetary motor

Accessories:

HK V0 590 - Shock valve

HK HM BMP HD
BMP HD CN gerotor motor

Connection: Oil connectors: A + B = G 1/2"; leak oil = G 1/4"
Design: Economy variant, Type "HD" with high-pressure gasket, two hole flange bolt circle 106,4, Shaft \varnothing 25mm
Intake and return pressure with leak oil line max.: 175 bar



Note: Please use a screw-in fitting with short thread when connecting a leak oil line to the motor.

Identification	Flow rate max. L/min	Displacement cc	Speed min. rpm	Speed max. rpm	Torque max. N-m	Pressure drop max. bar	Pmax. at				L mm	Weight kg
							0-100 rpm	100-300 rpm	300-600 rpm	>600 rpm		
HK HM BMP 050 HD	40	52,9	10	800	89	140	150	75	50	20	141	5,8
HK HM BMP 080 HD	60	79,3	10	770	149	140	150	75	50	20	145	5,9
HK HM BMP 100 HD	60	98,2	10	615	191	140	150	75	50	20	147	6,1
HK HM BMP 125 HD	60	120,9	10	480	235	140	150	75	50		150	6,2
HK HM BMP 160 HD	60	158,7	10	385	307	140	150	75	50		155	6,4
HK HM BMP 200 HD	60	196,4	10	310	365	140	150	75	50		160	6,6
HK HM BMP 250 HD	60	241,8	10	250	370	110	150	75			166	6,8
HK HM BMP 315 HD	60	317,3	10	195	370	90	150	75			176	7,1
HK HM BMP 400 HD	60	392,9	10	155	370	70	150	75			186	7,6

max. pressure on shaft seal (without leak oil line) or pressure in leak oil line Values for torque and pressure drop apply for continuous operation

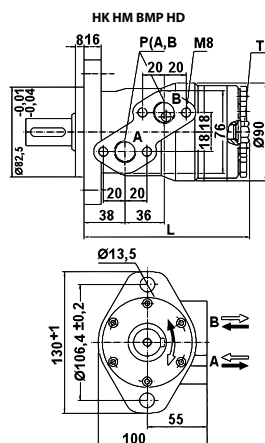

Web: <http://cat.hansa-flex.com/en/HKHMBMPHD>

Spare parts:
 HK HM BM DS - Seal kit for hydraulic planetary motor CN

Accessories:
 HK V0 590 - Shock valve

HK V0 590

Shock valve

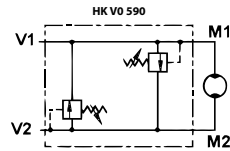

Design: Direct flange mounting, O-ring gasket
Material: Housing: Galvanised steel, Inside parts of steel
Operating pressure: max. 300 bar
Use: For hydraulic planetary motors

Note: These valves must be set according to the application.

Ordering information: Springs for other setting ranges available as accessories

Identification	Flow rate max. L/min	for motor	Connection	Setting range min. bar	Setting range max. bar	Weight kg
HK V0 590 0500	60	HK EPM, HK EPRM, HK HM BMP HD, HK HM BMR HD	G 1/2" - female thread	40	180	0,80
HK V0 590 0490	60	HK EPMS, HK HM BMS	G 1/2" - female thread	40	180	1,50
HK V0 590 0505	100	HK EPMT, HK HM BMT	G 3/4" - female thread	40	180	1,85

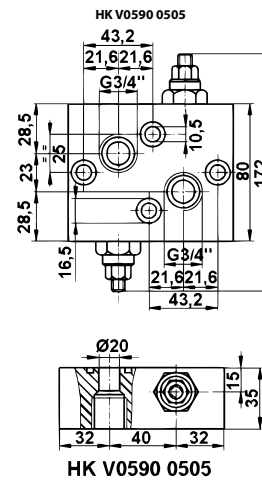
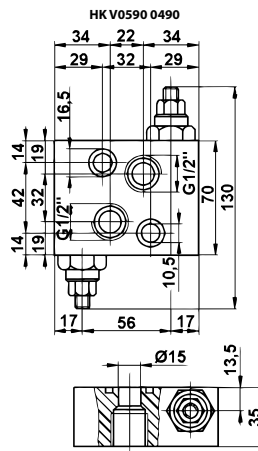
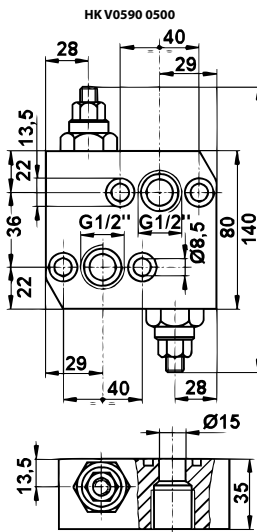

Web: <http://cat.hansa-flex.com/en/HKV0590>

Accessories:

HK VML - Spring for shock valve

HK M HK V0590 - Screw kit for shock valve HK V0590

HK VML

Spring for shock valve

Use: For shock valve HK V0590

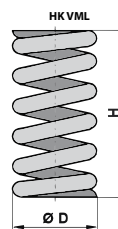

Identification	Setting range min. bar	Setting range max. bar	for valve type	H mm	Ø D mm	Weight kg
HK VML 100 0050	5	50	HK V0590 0500/HK V0590 0505	40,0	10,8	0,01
HK VML 102 0100	20	100	HK V0590 0500/HK V0590 0505	40,0	12,0	0,01
HK VML 105 0250	50	250	HK V0590 0500/HK V0590 0505	44,0	13,8	0,01
HK VML 108 0300	80	300	HK V0590 0500/HK V0590 0505	42,0	14,1	0,01
HK VML 005 050 UMS	5	50	HK V0590 0490	35,0	10,4	0,05
HK VML 020 100 UMS	20	100	HK V0590 0490	31,5	12,4	0,05
HK VML 050 250 UMS	50	250	HK V0590 0490	31,5	12,4	0,05
HK VML 080 300 UMS	80	300	HK V0590 0490	37,0	13,2	0,05

Web: <http://cat.hansa-flex.com/en/HKVML>

Accessory for following products:

HK V0 590 - Shock valve

HK M HK V0590

Screw kit for shock valve HK V0590

Design: Hexagon socket screw

Standard: DIN 912-12.9



Identification	Tightening torque N-m	for valve type	Scope of supply	Weight kg
HK M8 35	35,0	HK V0590 0500		0,10
HK M10 35	59,0	HK V0590 0490/HK V0590 0505		0,17

Web: <http://cat.hansa-flex.com/en/HKMHKV0590>

Accessory for following products:

HK V0 590 - Shock valve

HK EP DS**Seal kit for hydraulic planetary motor**

Use: For hydraulic planetary motors Typ HK EP ***

Identification	suitable for motor type	Weight kg
HK EPM-C-DS	HK EPM C	0,10
HK EPM-CD-DS	HK EPM CD	0,10
HK EPRM-C-DS	HK EPRM C	0,10
HK EPRM-CD-DS	HK EPRM CD	0,10
HK EPMS-C-DS-S3	HK EPMS C Ø 48	0,10
HK EPMM-C-DS	HK EPMM C	0,10
HK EPMT-C-DS	HK EPMT C	0,10

Web: <http://cat.hansa-flex.com/en/HKEPDS>

Spare part for following products:

HK EPMM C - EPMM gerotor motor

HK EPM CD - EPM gerotor motor

HK EPRM CD - EPRM geroller motor

HK EPMS - EPMS geroller motor

HK EPMT - EPMT geroller motor

HK HM BM DS**Seal kit for hydraulic planetary motor CN**

Use: For hydraulic planetary motors Typ HK HM ***

Identification	suitable for motor type	Weight kg
HK HM BMP HD-DS	HK HM BMP	0,20
HK HM BMR HD-DS	HK HM BMR	0,20
HK HM BMS-DS	HK HM BMS	0,20
HK HM BMT-DS	HK HM BMT	0,20

Web: <http://cat.hansa-flex.com/en/HKHMBMDS>

Spare part for following products:

HK HM BMP HD - BMP HD CN gerotor motor

HK HM BMR HD - BMR HD CN geroller motor

HK HM BMS - BMS CN geroller motor

HK HM BMT - BMT CN geroller motor

HK EPMM F

Flange for gerotor motor

Use: For gerotor motor type EPMM

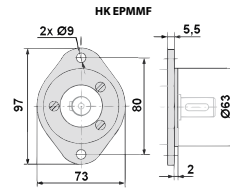

Note: Fastening to motor using 3 M6x14 screws
5 - 6 Nm tightening torque

Identification	Weight
HK EPMM F	kg 0,5

Web: <http://cat.hansa-flex.com/en/HKEPMMF>

Accessory for following products:
HK EPMM C - EPMM gerotor motor

HK V0 12

Pressure relief valve V012

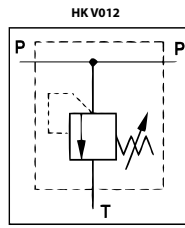

Design: direct-controlled
Material: Housing: Galvanised steel, Inside parts of steel
Operating pressure: max. 300 bar

Note: These valves must be set according to the application.
 No gauge port is provided for the 1/4" valves.

Identification	Connections P + T	Pressure setting range bar	Q max. L/min	H mm	L mm	L1 mm	S mm	Weight kg
HK V0 12 050 03	G 1/4"	10 - 50	25	30	52	97	40	0,53
HK V0 12 180 03	G 1/4"	10 - 180	25	30	52	97	40	0,53
HK V0 12 300 03	G 1/4"	80 - 300	25	30	52	97	40	0,53
HK V0 12 050 06	G 3/8"	10 - 50	40	40	72	141	40	0,86
HK V0 12 100 06	G 3/8"	20 - 100	40	40	72	141	40	0,86
HK V0 12 180 06	G 3/8"	10 - 180	40	40	72	141	40	0,86
HK V0 12 250 06	G 3/8"	50 - 250	40	40	72	141	40	0,86
HK V0 12 300 06	G 3/8"	80 - 300	40	40	72	141	40	0,86
HK V0 12 050 08	G 1/2"	10 - 50	55	45	77	146	45	1,10
HK V0 12 100 08	G 1/2"	20 - 100	55	45	77	146	45	1,10
HK V0 12 180 08	G 1/2"	10 - 180	55	45	77	146	45	1,10
HK V0 12 250 08	G 1/2"	50 - 250	55	45	77	146	45	1,10
HK V0 12 300 08	G 1/2"	80 - 300	55	45	77	146	45	1,10
HK V0 12 050 12	G 3/4"	10 - 50	90	50	92	161	50	1,30
HK V0 12 100 12	G 3/4"	20 - 100	90	50	92	161	50	1,30
HK V0 12 180 12	G 3/4"	10 - 180	90	50	92	161	50	1,30
HK V0 12 250 12	G 3/4"	50 - 250	90	50	92	161	50	1,30
HK V0 12 300 12	G 3/4"	80 - 300	90	50	92	161	50	1,30

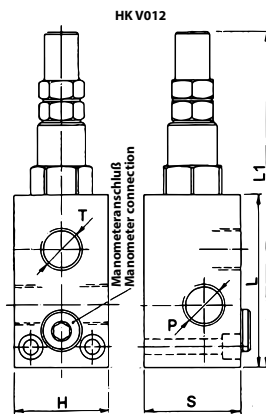

Web: <http://cat.hansa-flex.com/en/HKV012>

HK VMP BL
VMP BL pressure relief valve

Design: direct-controlled
Material: Inside parts of steel
Operating pressure: max. 350 bar

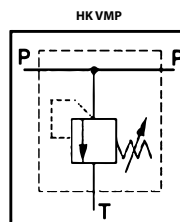

Note: These valves must be set according to the application.

Identification	Setting	Connections P + T	Pressure setting range bar	Q max. L/min	A	B	D	E	F	G	Depth mm	Material	Z mm	Weight kg
					mm	mm	mm	mm	mm	mm				
HK VMP BL 03 14 V	Hand-wheel	G 1/4"	50 - 220	10	60	60	48	14	30	32	30	Alu	6,5	0,42
HK VMP BL 05 38 V	Hand-wheel	G 3/8"	50 - 220	35	60	70	35	18	48	34	35	Alu	6,5	0,48
HK VMP BL 10 12 V	Hand-wheel	G 1/2"	50 - 220	60	70	78	39	20	58	40	35	Alu	6,5	0,52
HK VMP BL 20 34 V	Hand-wheel	G 3/4"	50 - 220	100	70	100	50	22	54	57	50	Alu	8,5	0,67
HK VMP BL 20 100 V	Hand-wheel	G 1"	50 - 220	100	85	120	63	30	65	65	60	Alu	8,5	0,86
HK VMP BL 05 38 SV	Hand-wheel	G 3/8"	180 - 350	35	60	70	35	18	48	34	35	Steel	6,5	0,60
HK VMP BL 10 12 S V	Hand-wheel	G 1/2"	180 - 350	60	70	78	39	20	58	40	35	Steel	6,5	1,00
HK VMP BL 20 100 S V	Hand-wheel	G 1"	180 - 350	100	85	120	63	30	65	65	60	Steel	8,5	4,50
HK VMP BL 20 100	Screw	G 1"	50 - 220	100	85	120	63	30	65	65	60	Alu	8,5	0,86
HK VMP BL 20 100 S	Screw	G 1"	180 - 350	100	85	120	63	30	65	65	60	Steel	8,5	4,80

Material applies to the housing

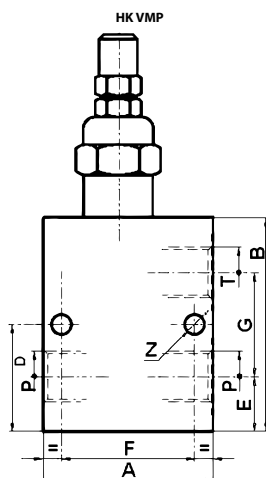

Web: <http://cat.hansa-flex.com/en/HKVMPL>

Accessories:

HK VMP BL F - Spring for VMPBL pressure relief valve

HK VMPP BL

VMPP BL pilot-controlled pressure relief valve

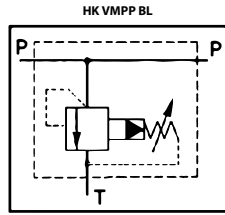

Design: pilot-controlled
Operating pressure: max. 350 bar

Note: These valves must be set according to the application.

Identification	Setting	Connections P + T	Pressure setting range bar	Q max. L/min	A	B	D	E	F	G	Depth mm	Material	Z	Weight kg
					mm	mm	mm	mm	mm	mm			mm	
HK VMPP BL 45 114	Screw	G 1.1/4"	50 - 220	250	100	135	70	35	80	68	70	Alu	10,5	1,20
HK VMPP BL 45 114 V	Hand-wheel	G 1.1/4"	50 - 220	250	100	135	70	35	80	68	70	Alu	10,5	1,20
HK VMPP BL 45 114 S	Screw	G 1.1/4"	180 - 350	250	100	135	70	35	80	68	70	Steel	10,5	1,45
HK VMPP BL 45 114 S V	Hand-wheel	G 1.1/4"	180 - 350	250	100	135	70	35	80	68	70	Steel	10,5	6,00

Material applies to the housing

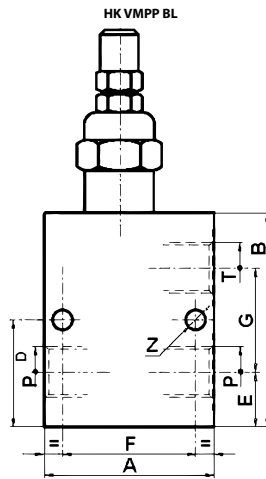

Web: <http://cat.hansa-flex.com/en/HKVMPPBL>

HK ARE

Pressure relief valve ARE

Design: direct-controlled, Type R with low internal leakage
Operating pressure: up to 500 bar

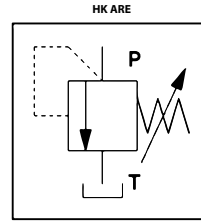

Note: These valves must be set according to the application.

Identification	Pressure setting range bar	Q max. L/min	A mm	B mm	Connection P	Connection T	Weight kg
HK ARE 06 100 R	3 - 100	40	140	62	G 1/4"	G 3/8"	1,0
HK ARE 06 210 R	10 - 210	40	140	62	G 1/4"	G 3/8"	1,0
HK ARE 06 350 R	15 - 350	40	140	62	G 1/4"	G 3/8"	1,0
HK ARE 06 500 R	30 - 500	40	140	62	G 1/4"	G 3/8"	1,0
HK ARE 15 15 R	2 - 15	75	165	62	G 1/2"	G 1/2"	1,3
HK ARE 15 75 R	4 - 75	75	165	62	G 1/2"	G 1/2"	1,3
HK ARE 15 150 R	8 - 150	75	165	62	G 1/2"	G 1/2"	1,3
HK ARE 15 250 R	8 - 250	75	165	62	G 1/2"	G 1/2"	1,3

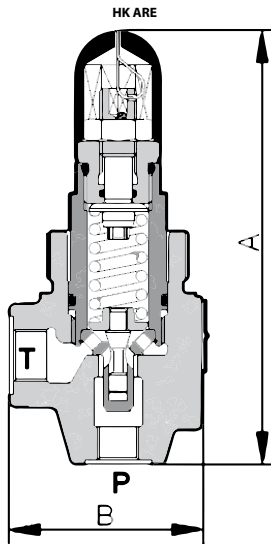

Web: <http://cat.hansa-flex.com/en/HKARE>

HK ARAM

Pressure relief valve ARAM

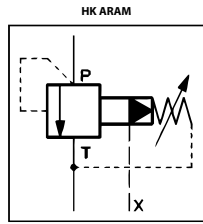

Design: pilot-controlled, with damping piston
Operating pressure: max. 350 bar

Note: These valves must be set according to the application.
 X port for optional remote control, sealed as standard

Identification	Pressure setting range bar	Q max. L/min	A mm	B mm	Connection P	Connection T	Connection X	Weight kg
HK ARAM 20 100	6 - 100	350	126	139	G 3/4"	G 1"	G 1/4"	3,9
HK ARAM 20 210	7 - 210	350	126	139	G 3/4"	G 1"	G 1/4"	3,9
HK ARAM 20 350	8 - 350	350	126	139	G 3/4"	G 1"	G 1/4"	3,9

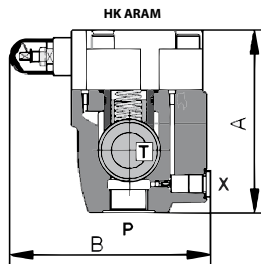

Web: <http://cat.hansa-flex.com/en/HKARAM>

HK FCV HN
Throttle valve

Precise volumetric flow control or barring in both directions
 Precise throttling over a wide flow rate range
 The hex. socket head screw in the setting knob serves for locking

Design: Economy variant, Steel version with precision valve spindle

Operating pressure: up to 400 bar

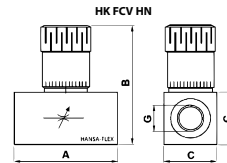

Note: These valves must be set according to the application.

Identification	Flow rate max. L/min	Pressure max. bar	A mm	B mm	C mm	G	Weight kg
HK FCV HN 400S 14	19	400	50	66	20	G 1/4"	0,20
HK FCV HN 600S 38	30	400	64	107	25	G 3/8"	0,40
HK FCV HN 800S 12	57	400	66	129	32	G 1/2"	0,60
HK FCV HN 1200S 34	95	320	82	142	38	G 3/4"	1,20
HK FCV HN 1600S 1	150	320	108	147	45	G 1"	2,50

Values for max. flow rate at $\Delta p = 20$ bar

Web: <http://cat.hansa-flex.com/en/HKFCVHN>

HK V2 572
Throttle valve

Precise volumetric flow control or barring in both directions
 Metallic seal without leakage, linear opening cross-section
 Precise throttling over a wide flow rate range
 The setting is made via a decimal scale from 0-9 on the underside of the setting knob and a reference scale A to C from 0 to 4 on the valve shaft for exactly reproducible settings

The hex. socket head screw in the setting knob serves for locking
 An additional lock nut is available for control panel installation

Design: Steel version with precision valve spindle, suitable for control panel installation

Operating pressure: up to 400 bar

Note: These valves must be set according to the application.

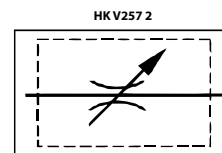

Identification	Flow rate max. L/min	Thread	Pressure bar	A mm	B mm	C mm	D mm	Weight kg
HK V2 572-1/8	8	G 1/8"	400	38	64	16	13,5	0,11
HK V2 572-1/4	14	G 1/4"	400	49	78	20	17,0	0,20
HK V2 572-3/8	38	G 3/8"	400	59	93	25	19,5	0,38
HK V2 572-1/2	50	G 1/2"	400	68	107	30	21,0	0,60
HK V2 572-3/4	80	G 3/4"	400	86	132	40	26,5	1,25
HK V2 572-1	190	G 1"	320	105	167	50	35,0	2,55
HK V2 572-1 1/4	200	G 1.1/4"	320	120	172	55	35,0	3,00
HK V2 572-1 1/2	350	G 1.1/2"	320	134	181	65	35,0	4,22
HK V2 572-2	450	G 2"	320	150	202	75	44,0	7,30

Values for max. flow rate at $\Delta p = 20$ bar

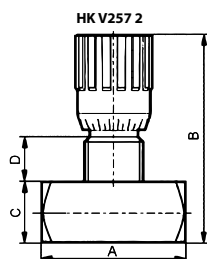

Web: <http://cat.hansa-flex.com/en/HKV2572>

Accessories:

HK KM 202 - Counter nut

DV IR

Throttle valve DV IR

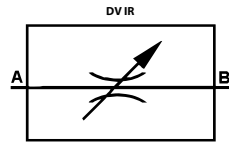

Design: Series EVN
Material: Gasket: NBR
Temp. max.: 100 °C
Media: Mineral oil
Operating pressure: max. 210 bar

Note: These valves must be set according to the application.

Ordering information: Seal: FPM (Viton) up to + 200°C on request.

Identification	Flow rate max. L/min	A mm	B mm	C mm	G1	Weight kg
DV 06 IR	15	36	60	17	G 1/4" -19	0,13
DV 10 IR	30	42	73	22	G 3/8" -19	0,25
DV 13 IR	50	57	85	27	G 1/2" -14	0,48

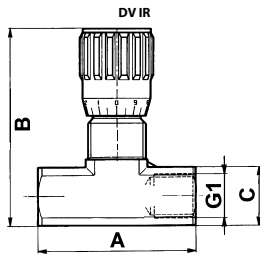

Web: <http://cat.hansa-flex.com/en/DVIR>

HK FCCV HF
Flow control check valve

Precise volumetric flow control or barring in one flow direction, free flow in the opposite direction

Precise throttling over a wide flow rate range

Opening pressure of the non-return valve 0.35 bar

The hex. socket head screw in the setting knob serves for locking

Design: Economy variant, Steel version with precision valve spindle

Operating pressure: up to 400 bar

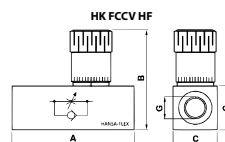

Note: These valves must be set according to the application.

Identification	Flow rate max. L/min	Pressure max. bar	A mm	B mm	C mm	G	Weight kg
HK FCCV HF 400S 14	19	400	67	45	20	G 1/4"	0,25
HK FCCV HF 600S 38	30	400	70	55	25	G 3/8"	0,50
HK FCCV HF 800S 12	57	400	87	69	32	G 1/2"	0,75
HK FCCV HF 1200S 34	95	320	99	86	38	G 3/4"	1,60
HK FCCV HF 1600S 1	150	320	127	124	45	G 1"	3,00

Values for max. flow rate at $\Delta p = 20$ bar

Web: <http://cat.hansa-flex.com/en/HKFCCVHF>

HK V2 575
Flow control check valve

Precise volumetric flow control or barring in one flow direction, free flow in the opposite direction

Metallic seal without leakage, linear opening cross-section

Precise throttling over a wide flow rate range

Opening pressure of the non-return valve 0.35 bar

Setting is as for the throttle valve

The hex. socket head screw in the setting knob serves for locking

An additional lock nut is available for control panel installation

Design: Steel version with precision valve spindle, suitable for control panel installation

Operating pressure: up to 400 bar

Note: These valves must be set according to the application.

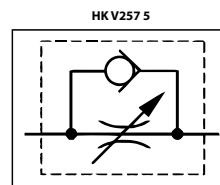

Identification	Flow rate max. L/min	Pressure bar	A mm	B mm	C mm	D mm	Thread	Weight kg
HK V2 575-1/8	8	400	50	64	16	13,5	G 1/8"	0,13
HK V2 575-1/4	14	400	66	78	20	17,0	G 1/4"	0,25
HK V2 575-3/8	38	400	79	93	25	19,5	G 3/8"	0,50
HK V2 575-1/2	50	400	95	107	30	21,0	G 1/2"	0,75
HK V2 575-3/4	80	400	115	132	40	26,5	G 3/4"	1,60
HK V2 575-1	190	320	139	167	50	35,0	G 1"	3,05
HK V2 575-1 1/4	200	320	157	172	55	35,0	G 1.1/4"	3,75
HK V2 575-1 1/2	350	320	190	181	65	35,0	G 1.1/2"	5,76
HK V2 575-2	450	320	228	202	75	44,0	G 2"	10,00

Values for max. flow rate at $\Delta p = 20$ bar

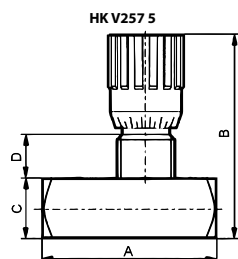

Web: <http://cat.hansa-flex.com/en/HKV2575>

Accessories:

HK KM 202 - Counter nut

DRV 1700

Regulating check valve DVR 1700

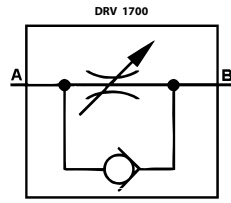

Media: Mineral oil
Operating pressure: max. 210 bar

Note: These valves must be set according to the application.

Identification	Flow rate max. L/min	G1	A mm	B mm	C mm	Weight kg
DRV 1700-1/4	15	G 1/4" -19	56	60	17	0,15
DRV 1700-3/8	30	G 3/8" -19	65	73	22	0,28
DRV 1700-1/2	50	G 1/2" -14	87	85	27	0,52

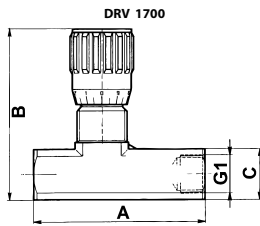

Web: <http://cat.hansa-flex.com/en/DRV1700>

HK V2 765 Z

Flow-control non-return valve V765Z

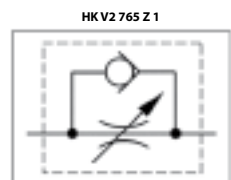

Design: Ball locking
Material: Housing: Cast iron, Inside parts of steel
Media: Mineral oil
Operating pressure: max. 300 bar

Note: These valves must be set according to the application.

Identification	p max. bar	Q max. L/min	L mm	D mm	G	Weight kg
HK V2 765 Z400	300	20	66	34	G 1/4"	0,27
HK V2 765 Z600	300	45	77	36	G 3/8"	0,33
HK V2 765 Z800	300	70	80	42	G 1/2"	0,49
HK V2 765 Z1000	250	110	95	51	G 3/4"	0,83

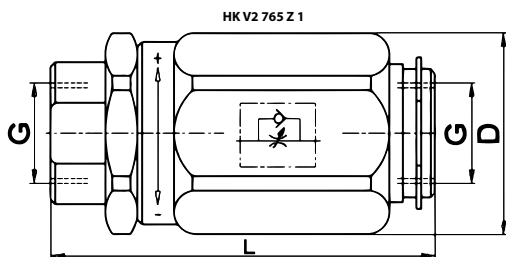

Web: <http://cat.hansa-flex.com/en/HKV2765Z>

HK AQFR

Throttle check valve AQFR

Design: Cone seat
Material: Steel
Media: Mineral oil
Operating pressure: max. 400 bar

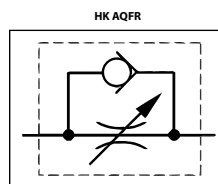

Note: These valves must be set according to the application.

Identification	p max. bar	Q max. L/min	L mm	G	AF mm	Weight kg
HK AQFR 10	400	30	93	G 3/8"	41	0,4
HK AQFR 15	350	50	105	G 1/2"	46	0,6
HK AQFR 20	350	80	127	G 3/4"	55	0,9
HK AQFR 25	350	160	153	G 1"	78	2,1
HK AQFR 32	350	250	196	G 1.1/4"	90	2,5

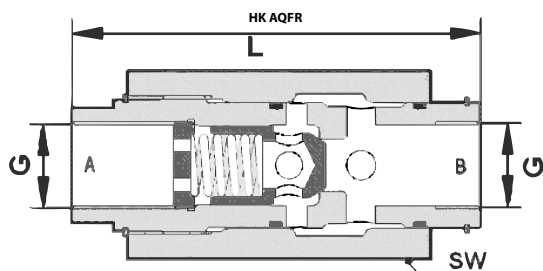

Web: <http://cat.hansa-flex.com/en/HKAQFR>

DRV IR

Regulating check valve DRV IR

Material: Steel
Media: Mineral oil
Operating pressure: max. 315 bar

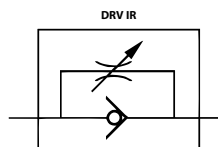

Note: These valves must be set according to the application.

Identification	G1	Q max. L/min	A mm	B mm	C mm	D mm	Weight kg
DRV 06 IR	G 1/4" -19	20	65	12	19	32	0,28
DRV 10 IR	G 3/8" -19	38	75	12	24	41	0,51
DRV 13 IR	G 1/2" -14	55	80	14	27	46	0,68
DRV 20 IR	G 3/4" -14	150	100	16	32	55	1,18
DRV 25 IR	G 1" -11	200	110	18	41	70	2,18

Qmax - max intake volumetric flow

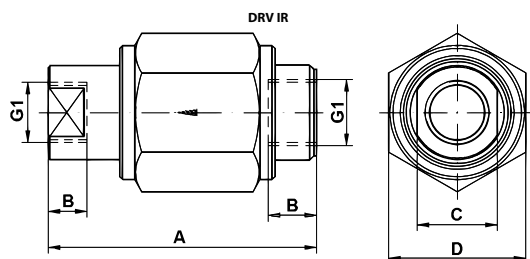

Web: <http://cat.hansa-flex.com/en/DRVIR>

HK V1 601

Line break safety valve without housing

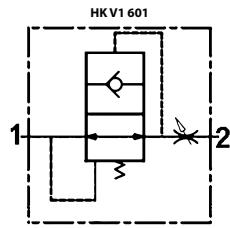

Material: Steel
Operating pressure: max. 300 bar

Note: Note: Line break safety valves must be set according to the application!
 The setting value "S" must correspond to 1.5 times the required volumetric flow for manually switched valves, and 2 times the required volumetric flow for electrically switched valves! Consider also the volumetric flow ratio with double-acting cylinders!

Identification	A	B	C	D	E	Q max.	Tightening torque	Weight
		mm	mm	mm	mm	L/min	N-m	kg
HK V1 601 0400	G 1/4"	8,0	2,5	8,0	5,0	25	15,0	0,01
HK V1 601 0600	G 3/8"	10,5	3,5	10,5	5,0	50	20,0	0,02
HK V1 601 0800	G 1/2"	13,0	4,5	12,5	5,0	80	40,0	0,02
HK V1 601 1200	G 3/4"	18,0	6,0	16,0	7,0	140	80,0	0,05

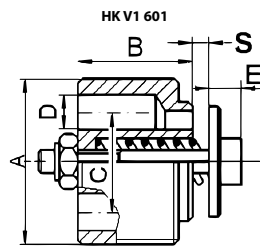
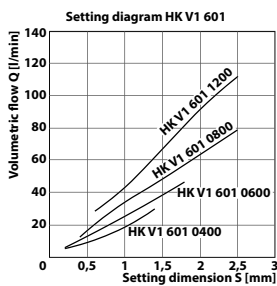

Web: <http://cat.hansa-flex.com/en/HKV1601>

Accessories:

- HK RV063 - Valve housing for line break safety valve
- HK LBS TOOL - Tool for line break safety valves

HK RV063
Valve housing for line break safety valve

Material: Steel
Operating pressure: max. 300 bar



Note: Note: Line break safety valves must be set according to the application!
 Information on settings, see HK V1 601 line break safety valves

Identification	H	M	N	O	AF	Weight
		mm	mm	mm	mm	kg
HK RV063 0400	G 1/4"	28	12	50	19	0,07
HK RV063 0600	G 3/8"	31	13	58	24	0,10
HK RV063 0800	G 1/2"	33	14	62	27	0,17
HK RV063 1200	G 3/4"	40	16	75	32	0,20

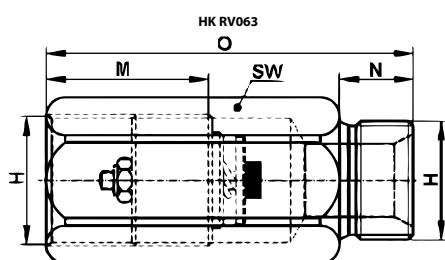

Web: <http://cat.hansa-flex.com/en/HKRV063>

Accessory for following products:
 HK V1 601 - Line break safety valve without housing

RBS IR
Burst pipe protection IR

Material: Steel
Operating pressure: max. 400 bar

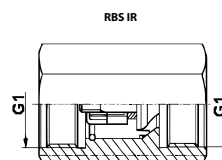

Identification	Operating pressure	G1	Closing quantity	Weight
	bar		L/min	kg
RBS 06-20 IR 10	400,0	G 3/8" -19	20	0,10
RBS 06-40 IR 10	400,0	G 3/8" -19	40	0,10
RBS 10-40 IR 13	315,0	G 1/2" -14	40	0,16
RBS 10-63 IR 13	315,0	G 1/2" -14	63	0,17
RBS 10-90 IR 13	315,0	G 1/2" -14	90	0,17
RBS 16-200 IR 25	250,0	G 1" -11	200	0,35

Web: <http://cat.hansa-flex.com/en/RBSIR>

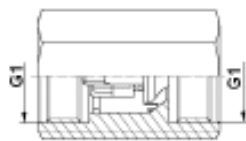
RBS M**Burst pipe protection M**

Material: Steel
Operating pressure: max. 400 bar

Identification	Operating pressure bar	G1	Closing quantity L/min	Weight kg
RBS 06-20 M 16	400,0	M 16 x 1.5	20	0,30
RBS 06-40 M 16	400,0	M 16 x 1.5	40	0,30
RBS 10-63 M 22	315,0	M 22 x 1.5	63	0,30
RBS 10-90 M 22	315,0	M 22 x 1.5	90	0,35
RBS 16-200 M 30	315,0	M 30 x 1.5	200	0,35

Web: <http://cat.hansa-flex.com/en/RBSM>

HK ADR
ADR non-return valve

Design: Cone locking
Material: Housing: Galvanised steel, Inside parts of steel
Operating pressure: max. 400 bar

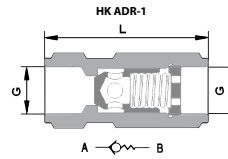

Identification	p max. bar	Opening pressure bar	Q max. L/min	G	L mm	AF mm	Weight kg
HK ADR 06	400	0,5	40	G 1/4"	67,0	22	0,2
HK ADR 10	400	0,5	80	G 3/8"	70,0	27	0,4
HK ADR 15	350	0,5	150	G 1/2"	82,5	32	0,6
HK ADR 20	350	0,5	300	G 3/4"	103,0	36	0,9
HK ADR 25	350	0,5	360	G 1"	120,0	46	2,1
HK ADR 32	350	0,5	500	G 1.1/4"	138,0	55	2,5

Web: <http://cat.hansa-flex.com/en/HKADR>

HK V1 501
V1501 non-return valve

Design: Cone locking
Material: Housing: Galvanised steel, Inside parts of steel
Operating pressure: max. 350 bar

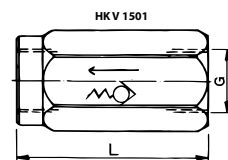

Identification	p max. bar	Opening pressure bar	Q max. L/min	G	L mm	AF mm	Weight kg
HK V1 501 0004	350	0,5	20	G 1/4"	62	19	0,12
HK V1 501 0006	350	0,5	40	G 3/8"	68	24	0,15
HK V1 501 0008	350	0,5	60	G 1/2"	77	30	0,28
HK V1 501 0012	300	0,5	100	G 3/4"	88	36	0,28
HK V1 501 0016	300	0,5	150	G 1"	105	41	0,35
HK V1 501 0020	250	0,5	200	G 1.1/4"	135	55	0,40

AF = Width across flats

Web: <http://cat.hansa-flex.com/en/HKV1501>

HK ADRL

ADRL non-return valve

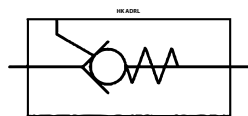

Design: Cone locking, pilot-controlled - single-acting
Material: Steel
Operating pressure: max. 400 bar

Identification	p max. bar	Opening pressure bar	Level control ratio	Q max. L/min	A mm	B mm	C mm	D mm	E mm	F mm	G mm	Weight kg
HK ADRL 10	400	0,5	1:2.8	30	41	120	30,0	14,0	G 3/8"	12	40,0	1,0
HK ADRL 15	350	0,5	1:2.7	60	50	145	33,0	16,0	G 1/2"	16	49,0	2,0
HK ADRL 20	350	0,5	1:2.5	100	55	175	42,5	18,5	G 3/4"	19	54,5	2,5
HK ADRL 32	350	0,5	1:2.3	300	90	245	53,0	23,5	G 1.1/4"	25	87,5	7,0

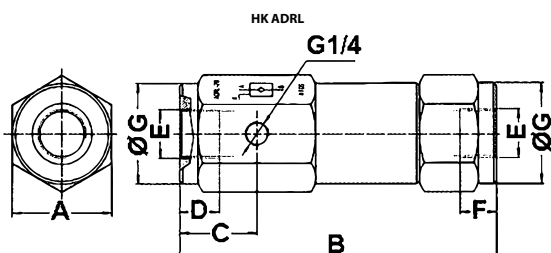

Web: <http://cat.hansa-flex.com/en/HKADRL>

HK V1 710

V1710 non-return valve

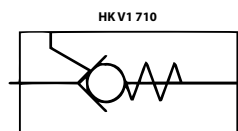

Design: Cone locking, pilot-controlled - single-acting
Material: Housing: Galvanised steel, Inside parts of hardened steel
Operating pressure: max. 320 bar

Note: Please note: max. thread depth S1 = 10.1 mm!

Identification	Opening pressure bar	Level control ratio	Q max. L/min	A mm	B mm	C mm	D mm	AF mm	Weight kg
HK V1 710 0004	2,5	1:9	15	103	31	1/4"	1/4"	36	0,60
HK V1 710 0006	5,0	1:6	35	112	35	1/4"	3/8"	40	0,82
HK V1 710 0008	3,0	1:4	45	120	38	1/4"	1/2"	42	1,10
HK V1 710 0012	0,5	1:4	80	151	45	1/4"	3/4"	55	1,90

AF = Width across flats

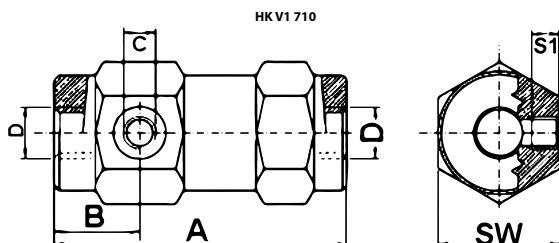

Web: <http://cat.hansa-flex.com/en/HKV1710>

HK V1 865
V1865 non-return valve

Design: Cone locking, pilot-controlled - double-acting
Material: Housing: Galvanised steel, Inside parts of hardened steel
Operating pressure: max. 350 bar

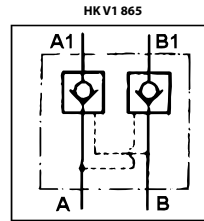

Identification	p max. bar	Opening pressure bar	Level control ratio	Q max. L/min	A mm	B mm	C	D mm	H mm	Weight kg
HK V1 865 0400	350	4,0	1:5.5	20	118	68	1/4" BSPP	38	40	0,66
HK V1 865 06NT	350	4,0	1:5.5	30	118	68	3/8" BSPP	38	40	0,66
HK V1 865 0800	300	4,0	1:5	45	144	80	1/2" BSPP	40	50	1,76
HK V1 865 M18X15	350	4,0	1:5.5	20	118	68	M 18 x 1.5	38	40	0,54

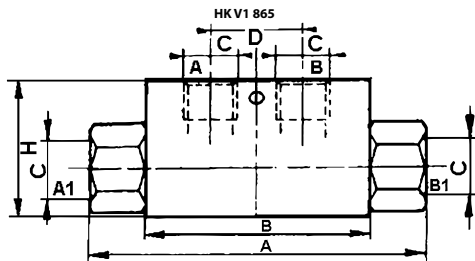

Web: <http://cat.hansa-flex.com/en/HKV1865>

HK V1 866
V1866 non-return valve

Design: Cone locking, pilot-controlled - double-acting
Material: Housing: Galvanised steel, Inside parts of hardened steel
Operating pressure: max. 350 bar
Connection: A1 and B1 with M18 x 1.5

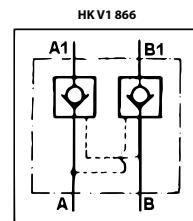

Identification	p max. bar	Opening pressure bar	Level control ratio	Q max. L/min	H mm	Weight kg
HK V1 866 0600	350	4,0	1:4.5	20	40	0,54

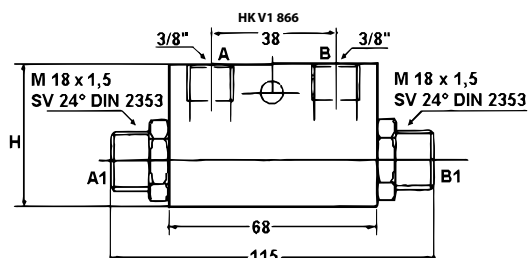

Web: <http://cat.hansa-flex.com/en/HKV1866>

HK VRDE

VRDE non-return valve for cylinder installation

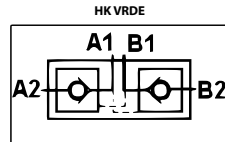

Design: Cone locking, pilot-controlled - double-acting, Direct flange mounting on cylinder
Scope of supply: incl. hollow screw and gaskets
Material: Steel housing
Operating pressure: max. 300 bar

Note: Recommended minimum distance of cylinder oil connections: 144 mm for HK VRDE 10 CIL / 150 mm for HK VRDE 20 CIL

Identification	Opening pressure bar	Level control ratio	Q max. L/min	A mm	B mm	C mm	D mm	E mm	F mm	G mm	Connection A1, A2, B1	Hollow screw B2	Weight kg
HK VRDE 10 CIL	0,6	1:4.5	20	88,5	84	68,5	24	40	27	10	G 1/4" - IG	1/4" AG	0,62
HK VRDE 20 CIL	0,6	1:4.9	20	90,5	86	72,0	26	45	31	12	G 3/8" - IG	3/8" AG	0,62

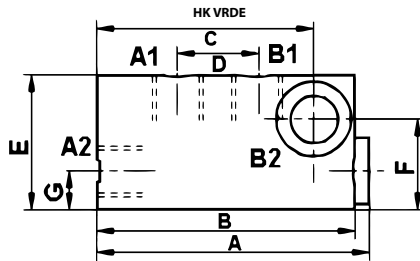

Web: <http://cat.hansa-flex.com/en/HKVRDE>

HK 055 211
Check valve SC, single-acting

Design: Cone locking, pilot-controlled - single-acting, Seat version - leak-free
Material: Housing: Aluminium, Inside parts of steel
Operating pressure: max. 350 bar

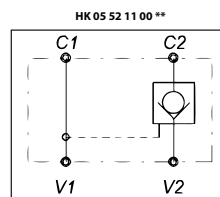

Identification	Thread	Opening pressure bar	Level control ratio	Q max. L/min	A	B	C	D	E	F	H	Weight kg
					mm	mm	mm	mm	mm	mm	mm	
HK 055 211 000 300	G 1/2"	1,0	1:3.2	50	95	35	50	38,5	25	32	38	0,70
HK 055 211 000 900	G 1/4"	2,0	1:4	20	70	35	40	33,5	0	24	35	0,36

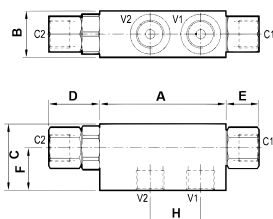
HK 055 211

Web: <http://cat.hansa-flex.com/en/HK055211>

HK 055 3
Check valve SC, double-acting

Design: Cone locking, pilot-controlled - double-acting, Seat version - leak-free
Material: Housing: Aluminium, Inside parts of steel
Operating pressure: max. 350 bar

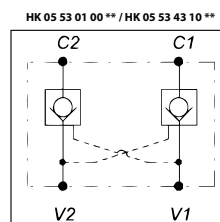

Identification	Thread	Opening pressure bar	Level control ratio	Q max. L/min	A	B	C	D	E	F	H	Weight kg
					mm	mm	mm	mm	mm	mm	mm	
HK 055 301 000 300	G 1/2"	1,5	1:3.2	50	110	35	69	40	69	35	34	0,92
HK 055 301 000 400	G 3/4"	1,5	1:4	100	165	50	89	60	105	44	50	2,61
HK 055 343 109 700	G 3/8"	1,0	1:7	30	123	35	60	40	62	30	32	0,64

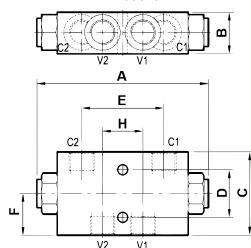
HK 055 3

Web: <http://cat.hansa-flex.com/en/HK0553>

HK 055 283

Check valve SC, single-acting with venting

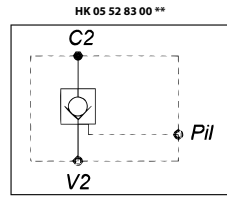

Design: Cone locking, pilot-controlled - single-acting, Seat version - leak-free, vented control range
Material: Housing: Aluminium, Inside parts of steel
Operating pressure: max. 350 bar

Identification	Thread	Opening pressure bar	Level control ratio	Q max. L/min	Weight kg
HK 055 283 000 200	G 3/8"	1,0	1:10	30	0,62
HK 055 283 000 201	G 3/8"	4,5	1:10	30	0,62

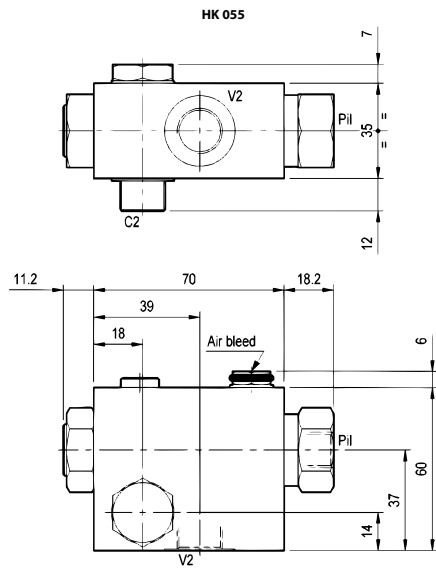

Web: <http://cat.hansa-flex.com/en/HK055283>

HK DRH

Non return valve RB

Design: Ball locking, pilot-controlled - double-acting
Material: Housing: Galvanised steel, Inside parts of steel
Operating pressure: max. 500 bar



Identification	p max. bar	Q max. L/min	A mm	B mm	C mm	D mm	E mm	G	L mm	AF mm	Weight kg
HK DRH 1	500	16	70	50	28,0	45	20	G 1/4"	6	19	0,50
HK DRH 2	500	30	89	63	36,0	60	30	G 3/8"	8	22	1,20
HK DRH 3	500	60	115	81	36,0	60	30	G 1/2"	10	27	1,60
HK DRH 4	400	90	150	106	55,0	70	40	G 3/4"	10	32	2,90

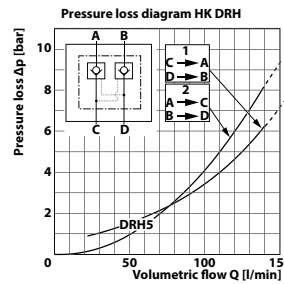
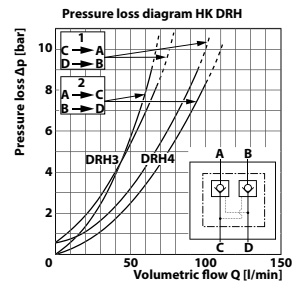
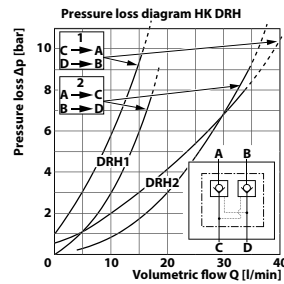
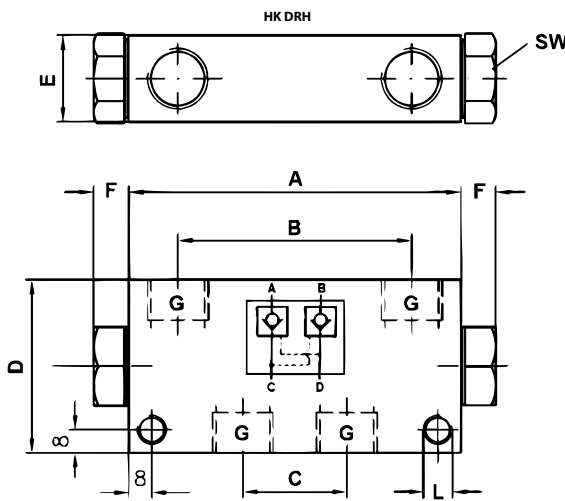

Web: <http://cat.hansa-flex.com/en/HKDRH>

HK RH

Non return valve RB

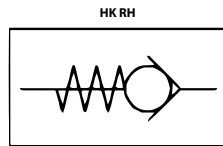

Type HK RH *** V with pre-release, a polished seat valve spool is used with ball check valve. This will pre-opened when unlock, the throttle effect allows a bumpless relaxation of oil volume. Mainly used for high operating pressures and high flow rates.

Pilot pressure ratio see diagram

Design: Ball locking, Type "V" with valve spool, pilot-controlled - single-acting

Material: Housing: Galvanised steel, Inside parts of steel

Operating pressure: max. 700 bar

Identification	p max. bar	Q max. L/min	A mm	B mm	G	L mm	AF mm	Weight kg
HK RH 1	700	15	31,5	27	G 1/4"	84	24	0,40
HK RH 2	700	35	32,0	29	G 3/8"	90	27	0,40
HK RH 3	500	55	36,5	31	G 1/2"	100	32	0,60
HK RH 3V	500	55	36,5	31	G 1/2"	100	32	0,60
HK RH 4	500	100	45,0	36	G 3/4"	126	41	1,30
HK RH 4V	500	100	45,0	36	G 3/4"	126	41	1,30

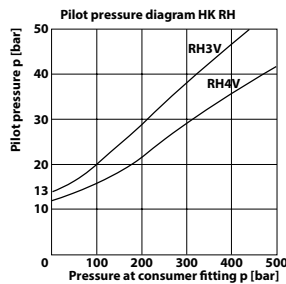
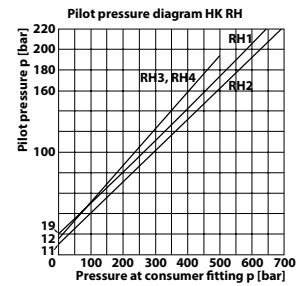
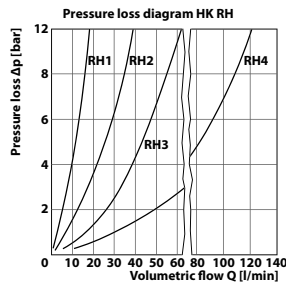
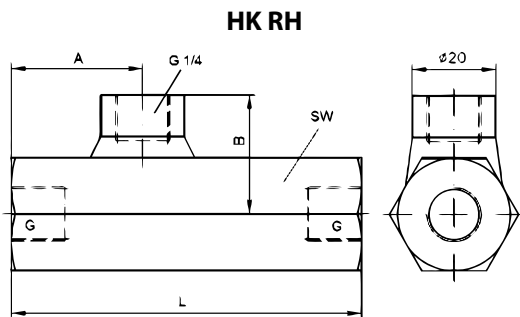

Web: <http://cat.hansa-flex.com/en/HK RH>

HK RK E

Non return valve with housing type E

Design: Ball locking, mounted in reverse direction
Material: Housing: Galvanised steel, Inside parts of steel
Operating pressure: max. 700 bar



Identification	p max. bar	Opening pressure bar	Q max. L/min	G	L mm	L1 mm	Ø D mm	Ø D1 mm	AF mm	Weight kg
HK RK 0 E	700	0,1	10	G 1/8"	8,0	28,0	14,0	12,5	14	0,03
HK RK 1 E	700	0,2	20	G 1/4"	12,0	43,0	19,0	12,5	19	0,06
HK RK 2 E	700	0,2	50	G 3/8"	12,0	44,0	22,0	20,5	22	0,09
HK RK 3 E	500	0,2	80	G 1/2"	14,0	52,0	26,0	24,0	27	0,14
HK RK 4 E	500	0,1	120	G 3/4"	16,0	60,0	32,0	30,0	36	0,30

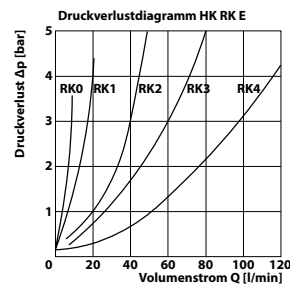
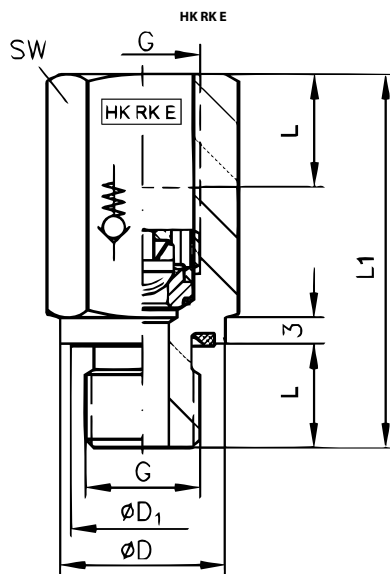

Web: <http://cat.hansa-flex.com/en/HKRKE>

Accessories:
 HK RK - Non return valve RK

HK RB F

Non return valve with housing type F



Design: Ball locking, mounted in flow direction
Material: Housing: Galvanised steel, Inside parts of steel
Operating pressure: max. 700 bar

1

Identification	p max. bar	Opening pressure bar	Q max. L/min	G	L mm	L1 mm	Ø D mm	Ø D1 mm	AF mm	Weight kg
HK RB 0 F	700	0,1	10	G 1/8"	8,0	28,0	14,0	12,5	14	0,03
HK RB 1 F	700	0,2	20	G 1/4"	12,0	43,0	19,0	12,5	19	0,06
HK RB 2 F	700	0,1	50	G 3/8"	12,0	44,0	22,0	20,5	22	0,09
HK RB 3 F	500	0,2	80	G 1/2"	14,0	52,0	26,0	24,0	27	0,14
HK RB 4 F	500	0,1	120	G 3/4"	16,0	60,0	32,0	30,0	36	0,30

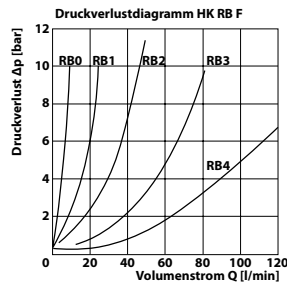
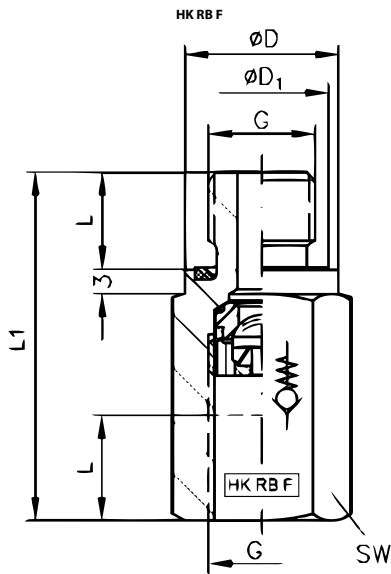

Web: <http://cat.hansa-flex.com/en/HKRBF>

Accessories:
 HK RB - Non return valve RB

Non return valve RK

Check valve for insertion into simple threaded boreholes (shoulder 118°).
Housing sealing by O-ring NBR.

Design: Ball locking, for mounting in reverse direction

Material: Steel

Operating pressure: max. 700 bar

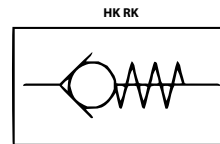

Note: For applications with greater shocks and vibration the valve must be secured with Loctite when screwing.

Identification	p max. bar	Opening pressure bar	Q max. L/min	G	L mm	L1 mm	LK mm	Ø D mm	Ø D1 mm	S mm	Tightening torque N-m	Weight kg
HK RK 0	700	0,1	10	G 1/8"	7,2	3,8	6,8	8,6	2,0	1,3	8,0	0,01
HK RK 1	700	0,2	20	G 1/4"	9,0	4,5	8,8	11,5	2,6	1,5	15,0	0,01
HK RK 2	700	0,2	50	G 3/8"	11,2	6,5	11,0	15,0	3,4	2,5	20,0	0,02
HK RK 3	500	0,2	80	G 1/2"	13,5	8,0	14,2	18,5	4,3	3,0	40,0	0,03
HK RK 4	500	0,1	120	G 3/4"	17,5	10,0	18,5	24,0	5,8	3,5	80,0	0,05

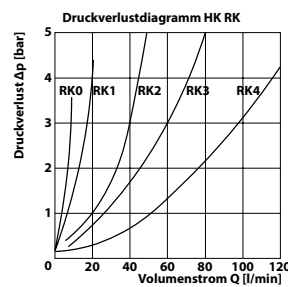
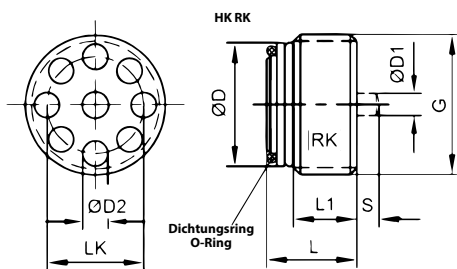

Web: <http://cat.hansa-flex.com/en/HK RK>

Accessory for following products:

HK GEH RK RB AG IG - Housing for non return valve RK/RB

HK GEH RK RB IG - Housing for non return valve RK/RB

Additional elements:

HK LBS TOOL RK - Tool for line break safety valves

HK RB

Non return valve RB

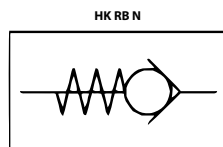

Check valve for insertion into simple threaded boreholes (shoulder 118 °).
Housing sealing by O-ring NBR.

Design: Ball locking, for mounting in flow direction
Material: Steel
Operating pressure: max. 700 bar

Note: For applications with greater shocks and vibration the valve must be secured with Loctite when screwing.

Identification	p max. bar	Opening pressure bar	Q max. L/min	G	L mm	L1 mm	Ø D mm	Ø D1 mm	S mm	AF mm	Tightening torque N-m	Weight kg
HK RB 0	700	0,1	10	G 1/8"	7,9	4,5	8,6	1,7	1,3	5	8,0	0,01
HK RB 1	700	0,2	20	G 1/4"	10,3	5,0	11,6	2,2	1,3	7	15,0	0,01
HK RB 2	700	0,1	50	G 3/8"	11,7	7,0	15,0	3,0	2,0	6	20,0	0,02
HK RB 3	500	0,2	80	G 1/2"	13,2	7,5	18,5	3,4	2,5	8	40,0	0,03
HK RB 4	500	0,1	120	G 3/4"	17,1	10,0	24,0	5,8	3,8	12	80,0	0,05

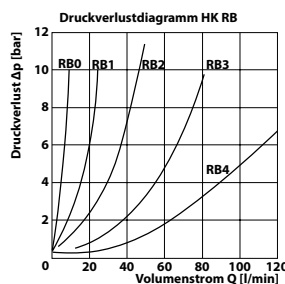
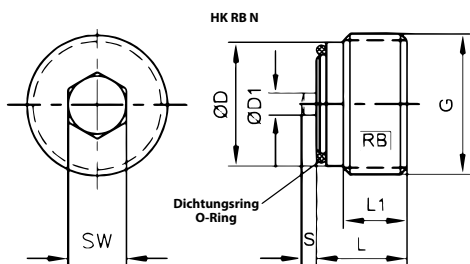

Web: <http://cat.hansa-flex.com/en/HKRB>

Accessory for following products:

HK GEH RK RB AG IG - Housing for non return valve RK/RB

HK GEH RK RB IG - Housing for non return valve RK/RB

HK GEH RK RB AG IG

Housing for non return valve RK/RB

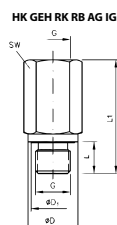

Material: Galvanised steel
Operating pressure: max. 700 bar

Identification	G	L mm	L1 mm	Ø D mm	Ø D1 mm	AF mm	Weight kg
HK GEH RKR B 0 AG IG	G 1/8"	8,0	28,0	14,0	12,5	14	0,02
HK GEH RKR B 1 AG IG	G 1/4"	12,0	43,0	19,0	12,5	19	0,05
HK GEH RKR B 2 AG IG	G 3/8"	12,0	44,0	22,0	20,5	22	0,07
HK GEH RKR B 3 AG IG	G 1/2"	14,0	52,0	26,0	24,0	27	0,11
HK GEH RKR B 4 AG IG	G 3/4"	16,0	60,0	32,0	30,0	36	0,26

Web: <http://cat.hansa-flex.com/en/HKGEHRKRBAIG>

Accessories:

HK RB - Non return valve RB

HK RK - Non return valve RK

HK GEH RK RB IG

Housing for non return valve RK/RB

Material: Galvanised steel
Operating pressure: max. 700 bar

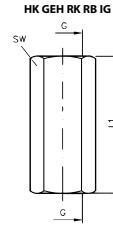

Identification	G	L1 mm	AF mm	Weight kg
HK GEH RKR 0 IG	G 1/8"	28,0	14	0,02
HK GEH RKR 1 IG	G 1/4"	43,0	19	0,05
HK GEH RKR 2 IG	G 3/8"	44,0	22	0,07
HK GEH RKR 3 IG	G 1/2"	52,0	27	0,11
HK GEH RKR 4 IG	G 3/4"	60,0	36	0,26

Web: <http://cat.hansa-flex.com/en/HKGEHRKRBIG>

Accessories:

HK RB - Non return valve RB
HK RK - Non return valve RK

HK V2 190

V2190 lowering valve

Design: single-acting
Material: Housing: Galvanised steel, Inside parts of steel
Operating pressure: max. 350 bar

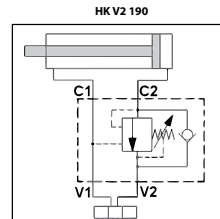

Note: When using these valve with a plunger cylinder, an additional pressure relief valve must be installed in the V1 line that has to be matched to the load pressure of the cylinder. This pressure relief valve must discharge to the tank. These rate-of-drop valves must be set according to the application.

Identification	Thread	Q max. L/min	Level control ratio	H mm	L mm	L1 mm	L2 mm	L3 mm	S mm	Weight kg
HK V2 190 A600	G 3/8"	40	1:4	60	100	148	30	60	30	1,21
HK V2 190 A800	G 1/2"	60	1:4	60	100	148	35	65	30	1,15

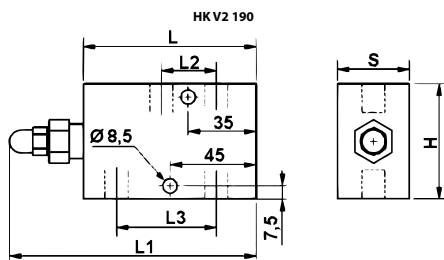

Web: <http://cat.hansa-flex.com/en/HKV2190>

HK V2 290

V2290 lowering valve

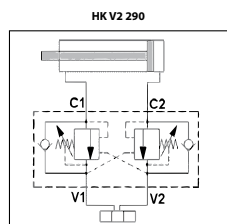

Design: double-acting
Material: Housing: Galvanised steel, Inside parts of steel
Operating pressure: max. 350 bar

Note: These rate-of-drop valves must be set according to the application.

Identification	Thread	Q max. L/min	Level control ratio	H mm	L mm	L1 mm	L2 mm	L3 mm	S mm	Weight kg
HK V2 290 A600	G 3/8"	40	1:4	60	150	246	50	110	30	1,74
HK V2 290 A800	G 1/2"	60	1:4	60	150	246	50	110	30	1,70

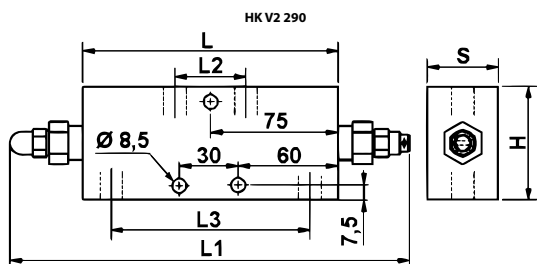

Web: <http://cat.hansa-flex.com/en/HKV2290>

HK 054 2

Counterbalancing valve SC, double-acting

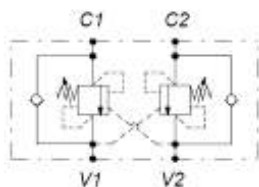

Design: double-acting, Pilot controlled, Seat version - leak-free
Material: Housing: Aluminium, Inside parts of steel
Operating pressure: max. 350 bar

Note: Max. load pressure 250 bar

Identification	Thread	Pressure setting range bar	Q max. L/min	Level control ratio	A mm	B mm	C mm	D mm	E mm	F mm	H mm	Weight kg
HK 054 247 100 220	G 3/8"	60 - 210	40	1:2.92	204	30	60	124	69	26	34	0,83
HK 054 247 100 235	G 3/8"	120 - 350	40	1:2.92	204	30	60	124	69	26	34	0,83
HK 054 201 030 320	G 1/2"	60 - 210	120	1:8.2	265	35	70	145	80	32	36	1,41
HK 054 201 030 335	G 1/2"	120 - 350	120	1:8.2	265	35	70	145	80	32	36	1,41
HK 054 201 030 435	G 3/4"	120 - 350	140	1:8.2	295	40	90	175	107	38	50	1,51

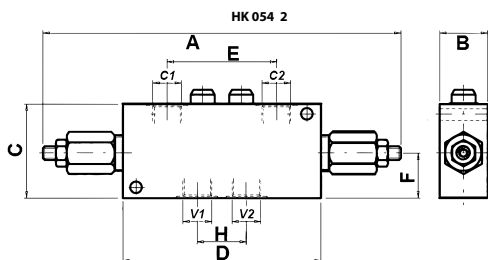

Web: <http://cat.hansa-flex.com/en/HK0542>

HK 054 322

Counterbalancing valve SC, single-acting

Design: single-acting, Pilot controlled, Seat version - leak-free
Material: Housing: Aluminium, Inside parts of steel
Operating pressure: max. 350 bar

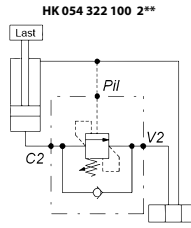

Note: Max. load pressure 250 bar

Identification	Thread	Pressure setting range bar	Q max. L/min	Level control ratio	A	B	C	D	E	F	H	I	Design	Weight kg
					mm	mm	mm	mm	mm	mm	mm	mm		
HK 054 322 100 220	G 3/8"	60 - 210	40	1:3.55	160	30	60	20	40	65	12	100	-	0,75
HK 054 322 100 235	G 3/8"	120 - 350	40	1:3.55	160	30	60	20	40	65	12	100	-	0,75
HK 054 322 100 320	G 1/2"	60 - 210	70	1:3.55	185	35	80	26	41	71	18	107	with measurement connector	1,20
HK 054 322 100 335	G 1/2"	120 - 350	70	1:3.55	185	35	80	26	41	71	18	107	with measurement connector	1,29

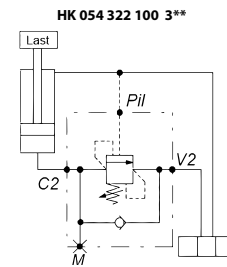
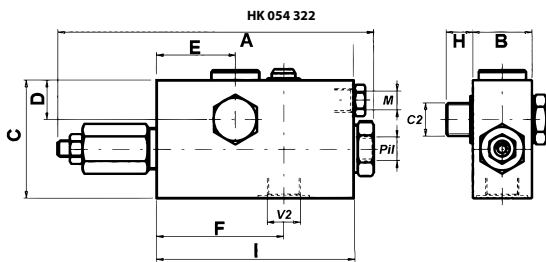

Web: <http://cat.hansa-flex.com/en/HK054322>

HK FPMD

Pressure relief valve FPMD (shock valve)

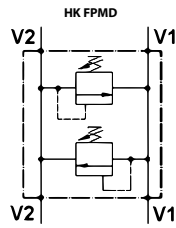

Design: direct-controlled, double-acting
Operating pressure: max. 250 bar with aluminium housing / max. 350 bar with steel housing

Note: These valves must be set according to the application.

Identification	Pressure setting range bar	Pressure max. bar	A mm	B mm	C mm	D mm	E mm	Thread V1 + V3	Volumetric flow max. L/min	Materi- al	Ø F mm	G mm	Weight kg
HK FPMD 40 ILP 38 A20	50 - 220	250	78	80	35	32	57	G 3/8"	50,0	Alu	9	30	0,6
HK FPMD 40 ILP 38 S35	80 - 350	350	78	80	35	32	57	G 3/8"	40,0	Steel	9	30	0,8
HK FPMD 70 ILP 12 A20	80 - 250	250	92	100	40	34	57	G 1/2"	80,0	Alu	9	38	1,0
HK FPMD 70 ILP 12 S35	100 - 350	350	92	100	40	34	57	G 1/2"	80,0	Steel	9	38	1,3

Material applies to the housing

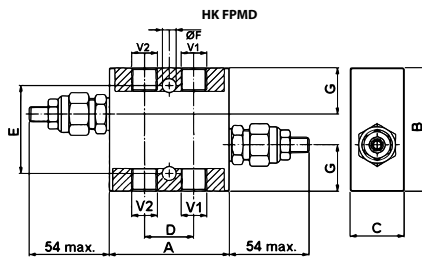

Web: <http://cat.hansa-flex.com/en/HKFPMD>

HK V6 215

flow control valve

With these 3-way flow control valves, the preferred oil flow (P) is held constant irrespective of the incoming oil flow (IN). The residual oil flow (B) can be diverted to the tank or used for an ancillary consumer

Division: max. 75 % of quantity from IN to P, min. 5 l/min to P

Design: pressure-compensated

Material: Housing: Cast iron, Inside parts of steel

Operating pressure: max. 250 bar

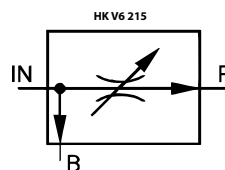

Note: These valves must be set according to the application.

Identification	Thread IN/B	Thread P	Inlet max. L/min	Width mm	Height mm	Length mm	Weight kg
HK V6 215 0320	G 1/2"	G 3/8"	40	65	98	87	1,26
HK V6 215 0322	G 3/4"	G 1/2"	70	80	101	106	1,75

Web: <http://cat.hansa-flex.com/en/HKV6215>

HK V6 215 DBV

Flow control valve with secondary pressure relief

With these 3-way flow control valves, the preferred oil flow (P) is held constant irrespective of the incoming oil flow (IN). The residual oil flow (B) can be diverted to the tank or used for an ancillary consumer

Division: max. 75 % of quantity from IN to P, min. 5 l/min to P

Design: pressure-compensated, with additional secondary pressure relief valve

Material: Housing: Cast iron, Inside parts of steel

Operating pressure: max. 250 bar

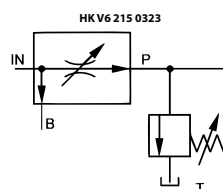

Note: These valves must be set according to the application.

Identification	Thread IN/B	Thread P	Inlet max. L/min	Width mm	Height mm	Length mm	Weight kg
HK V6 215 0323	G 3/4"	G 1/2"	70	80	125	106	1,84

Web: <http://cat.hansa-flex.com/en/HKV6215DBV>

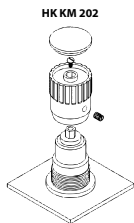
HK KM 202**Counter nut**

Installation: Release the lock of the handwheel
Loosen slotted screw under the PVC cap
Remove handwheel
Install valve using the lock nut

Use: For control panel installation of valves HKV257 2 and HK V257 5

Identification	Thread	for valve size	Weight kg
HK KM 202-1/8	M 17 x 1	1/8"	0,02
HK KM 202-1/4	M 20 x 1	1/4"	0,04
HK KM 202-3/8	M 25 x 1.5	3/8"	0,06
HK KM 202-1/2	M 30 x 1.5	1/2"	0,08
HK KM 202-3/4	M 40 x 1.5	3/4"	0,10
HK KM 202-1	M 50 x 1.5	1"	0,12
HK KM 202-1 1/4	M 50 x 1.5	1.1/4"	0,14
HK KM 202-1 1/2	M 55 x 2	1.1/2"	0,16
HK KM 202-2	M 65 x 2	2"	0,18

Web: <http://cat.hansa-flex.com/en/HKKM202>

Accessory for following products:

HK V2 572 - Throttle valve

HK V2 575 - Flow control check valve

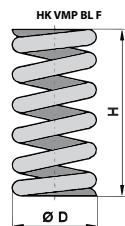
HK VMP BL F**Spring for VMPBL pressure relief valve**

Use: for pressure relief valve HK VMP BL

Identification	Pressure setting range bar	suitable for valve with connection T+P	H	Ø D	Weight kg
			mm	mm	
HK VMP BL 14 050	5 - 50	1/4"	25,1	8,6	0,01
HK VMP BL 14 220	50 - 220	1/4"	24,8	8,6	0,01
HK VMP BL 14 350	180 - 350	1/4" (steel housing only)	25,0	8,7	0,01
HK VMP BL 38 040	4 - 40	3/8"	30,3	13,6	0,02
HK VMP BL 38 080	20 - 80	3/8"	33,0	13,4	0,02
HK VMP BL 38 220	50 - 220	3/8"	33,7	14,0	0,02
HK VMP BL 38 350	180 - 350	3/8" (steel housing only)	35,8	14,3	0,02
HK VMP BL 12 040	4 - 40	1/2"	41,0	15,3	0,02
HK VMP BL 12 080	20 - 80	1/2"	42,2	14,8	0,02
HK VMP BL 12 220	50 - 220	1/2"	42,2	16,8	0,02
HK VMP BL 12 350	180 - 350	1/2" (steel housing only)	41,7	16,2	0,02
HK VMP BL 34 20 040	4 - 40	3/4" and 1"	42,0	17,5	0,02
HK VMP BL 34 20 080	20 - 80	3/4" and 1"	45,5	16,9	0,02
HK VMP BL 34 20 220	50 - 220	3/4" and 1"	42,1	20,1	0,02
HK VMP BL 34 20 350	180 - 350	3/4" and 1" (steel housing only)	45,1	20,5	0,02

Web: <http://cat.hansa-flex.com/en/HKVMPBLF>

Accessory for following products:

HK VMP BL - VMP BL pressure relief valve

HK LBS TOOL

Tool for line break safety valves

With this tool line break safety valves can be screwed into the corresponding housing.

Surface: galvanised
use: for valve type HK V1 601
Material: Steel



Note: For applications with greater shocks and vibration the valve must be secured with Loctite when screwing.

Identification	L mm	Ø A mm	Ø B mm	Ø C mm	Ø D mm	Ø F mm	Weight kg
HK LBS TOOL 1/4	68,0	15,9	11,5	6,3	8,0	2,35	0,06
HK LBS TOOL 3/8	68,0	15,9	14,8	6,3	10,0	3,25	0,08
HK LBS TOOL 1/2	76,0	24,9	18,7	8,0	11,9	4,35	0,17
HK LBS TOOL 3/4	76,0	24,9	23,5	8,0	16,0	5,95	0,25

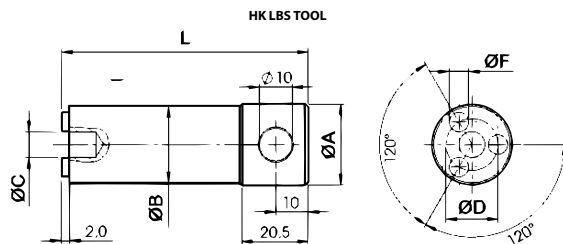

Web: <http://cat.hansa-flex.com/en/HKLBSTOOL>

Accessory for following products:

HK V1 601 - Line break safety valve without housing

HK LBS TOOL RK**Tool for line break safety valves**

With this tool line break safety valves can be screwed into the corresponding housing.

Surface: galvanised
use: for valve type HK RK
Material: Steel

Note: For applications with greater shocks and vibration the valve must be secured with Loctite when screwing.

Identification	L mm	L1 mm	Ø A mm	Ø B mm	Ø C mm	Ø D mm	AF mm	Weight kg
HK LBS TOOL RK 0 1/8	70,0	13	6,9	8,4	4,0	1,4	17	0,04
HK LBS TOOL RK 1 1/4	70,0	13	8,9	11,3	6,8	1,8	17	0,06
HK LBS TOOL RK 2 3/8	70,0	13	11,1	14,8	6,8	2,8	17	0,08
HK LBS TOOL RK 3 1/2	70,0	18	14,3	18,5	8,7	3,2	27	0,17
HK LBS TOOL RK 4 3/4	70,0	18	18,6	24,0	12,5	4,1	27	0,24

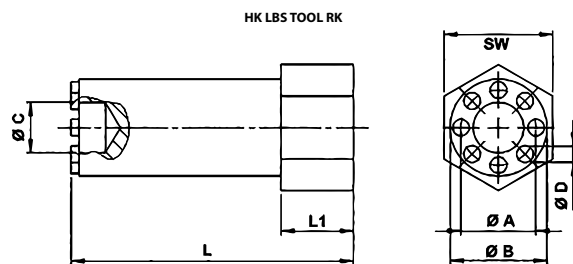

Web: <http://cat.hansa-flex.com/en/HKLBSTOOLRK>

Accessory for following products:

HK RK - Non return valve RK

HK RVPS

Pressure relief valve RVPS

Setting via setscrew

Design: pilot-controlled

Operating pressure: max. 350 bar

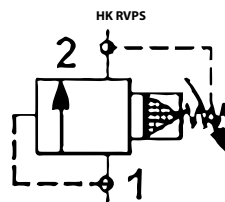

Note: These valves must be set according to the application.

Tightening torque for valve size 12 with Alu housing: 74-81 Nm

Tightening torque for valve size 12 with Steel housing: 95-102 Nm

Identification	Setting range min. bar	Setting range max. bar	Volumetric flow max. L/min	Screw-in housing	Screw-in thread	Weight kg
HK RVPS 12 NSO 15	7	105	230,0	HK GEH 12 C1220/HK GEH 34 C1220	SAE 12/2 1.1/16"-12UNF-2B	0,25
HK RVPS 12 NSO 50	35	350	230,0	HK GEH 12 C1220/HK GEH 34 C1221	SAE 12/2 1.1/16"-12UNF-2B	0,25

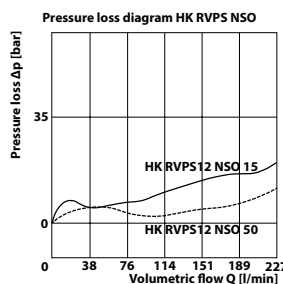
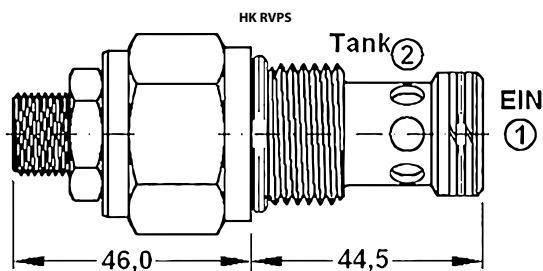

Web: <http://cat.hansa-flex.com/en/HKRVPS>

Accessories:

HK GEH 20 AL - Aluminium housing for SAE 2-way cartridge valve

HK GEH 20 GGG - GGG40 housing for SAE 2-way cartridge valve

HK RD

Pressure relief valve RD

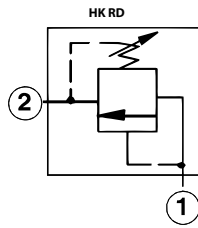

Only adjustable when pressure at port 1 < 50 bar
 connection 2 can be loaded with max. pressure
 Response time approx. 2 ms
Design: direct-controlled
Operating pressure: max. 350 bar

Note: These valves must be set according to the application.

Identification	Setting range		Qmax	A	B	Screw-in housing	Screw-in thread	AF	Tightening torque	Weight
	min. bar	max. bar								
HK RD DA LAN	35	210	95 L/min	61,0 mm	40,0 mm	HK FAU/HK FAUS	T-10A	22 mm	50,0 N-m	0,5 kg
HK RD DA LWN	55	315	95 L/min	61,0 mm	40,0 mm	HK FAU/HK FAUS	T-10A	22 mm	50,0 N-m	0,5 kg
HK RD FA LAN	35	210	200 L/min	64,0 mm	48,0 mm	HK CAV/HK CAVS/HK CAW/HK CAWS	T-3A	28 mm	65,0 N-m	0,5 kg
HK RD FA LWN	55	315	200 L/min	64,0 mm	48,0 mm	HK CAV/HK CAVS/HK CAW/HK CAWS	T-3A	28 mm	65,0 N-m	0,5 kg

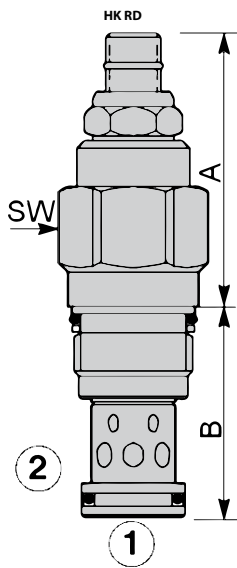

Web: <http://cat.hansa-flex.com/en/HKRD>

Accessories:

- HK GEH CA - Valve housing for cartridge valve T-3A
- HK GEH FA - Valve housing for cartridge valve T-10A
- HK HR SUN - Hand wheel for cartridge valve SUN

Pressure relief valve RP

Only adjustable when pressure at port 1 < 50 bar
 connection 2 can be loaded with max. pressure
 Response time approx. 10 ms

Design: pilot-controlled

Operating pressure: max. 350 bar

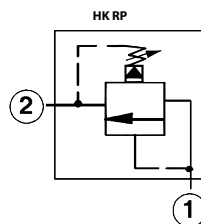

Note: These valves must be set according to the application.

Identification	Setting range		Qmax	A	B	Screw-in housing	Screw-in thread	AF	Tightening torque	Weight
	min. bar	max. bar								
HK RP EC LAN	7	210	95	51,0	40,0	HK FAU/HK FAUS	T-10A	22	50,0	0,5
HK RP EC LWN	10	315	95	51,0	40,0	HK FAU/HK FAUS	T-10A	22	50,0	0,5
HK RP GC LAN	7	210	200	54,0	48,0	HK CAV/HK CAVS/HK CAW/HK CAWS	T-3A	28	65,0	0,5
HK RP GC LWN	10	315	200	54,0	48,0	HK CAV/HK CAVS/HK CAW/HK CAWS	T-3A	28	65,0	0,5

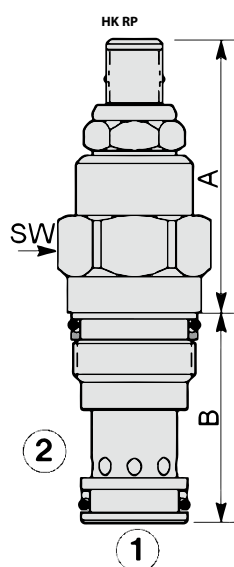

Web: <http://cat.hansa-flex.com/en/HKRP>

Accessories:

HK GEH CA - Valve housing for cartridge valve T-3A

HK GEH FA - Valve housing for cartridge valve T-10A

HK HR SUN - Hand wheel for cartridge valve SUN

HK PRRS

3-way pressure reduction valve PRRS

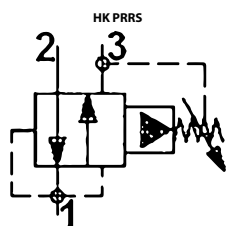

Setting via setscrew
 Design: pilot-controlled
 Operating pressure: max. 350 bar

Note: These valves must be set according to the application.
 Tightening torque for valve size 10 with Alu housing: 47-54 Nm
 Tightening torque for valve size 10 with Steel housing: 74-81 Nm

Identification	Setting range min. bar	Setting range max. bar	Pressure max. bar	Volumetric flow max. L/min	Screw-in housing	Screw-in thread	Weight kg
HK PRRS 10 NSO 06	5	40	350	46,0	HK GEH 38 C1030	SAE 10/2 7/8"-14UNF-2B	0,2
HK PRRS 10 NSO 15	5	100	350	46,0	HK GEH 38 C1030	SAE 10/2 7/8"-14UNF-2B	0,2
HK PRRS 10 NSO 30	5	210	350	46,0	HK GEH 38 C1030	SAE 10/2 7/8"-14UNF-2B	0,2

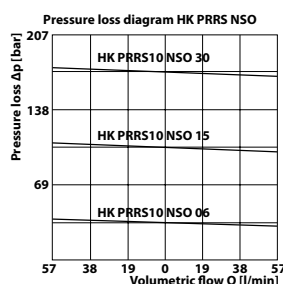
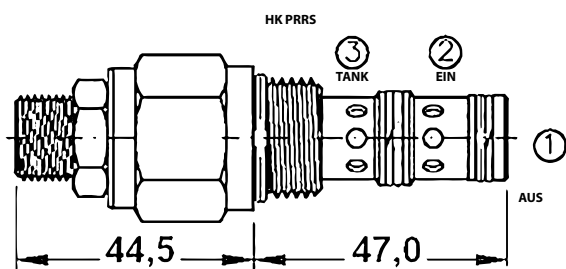

Web: <http://cat.hansa-flex.com/en/HKPRRS>

Accessories:

- HK GEH 30 AL - Aluminium housing for SAE 3-way cartridge valve
- HK GEH 30 GGG - GGG40 housing for SAE 3-way cartridge valve

HK CK XCN

Non-return valve CK

pressure at connection 2 decreases the required control pressure

Design: Pilot-controlled, without relief, Steel seat

Operating pressure: max. 350 bar

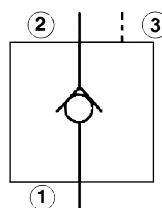

Identification	Q _{max} L/min	A mm	B mm	Screw-in housing	Screw-in thread	AF mm	Tightening torque N-m	Weight kg
HK CK CB XCN	60	30,0	35,0	HK ECU/HK ECUS	T-11A	22	50,0	0,5
HK CK EB XCN	120	35,0	35,0	HK BCV/HK BCVS/HK BCW/HK BCWS	T-2A	28	65,0	0,5

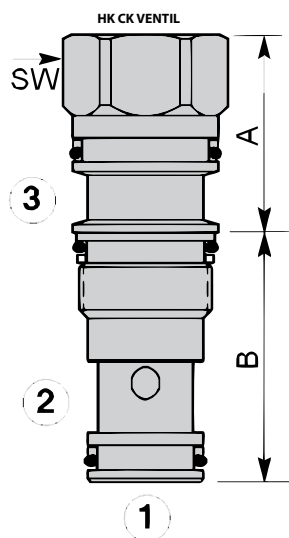

Web: <http://cat.hansa-flex.com/en/HKCKXCN>

Accessories:

HK GEH BC - Valve housing for cartridge valve T-2A

HK GEH EC - Valve housing for cartridge valve T-11A

HK HR SUN - Hand wheel for cartridge valve SUN

HK CB L

Overcentre valve CB

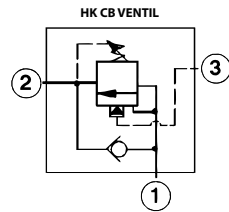

load-holding function to 210bar (with setting 280 bar, opening of load pressure 0 bar)
 Load-dependent opening for controlling negative (dragging) loads
 back pressure on connection 2 can impair the functioning of the valve
 closing pressure $\geq 85\%$ of the opening pressure
 Note! Relief function by screwing in the spindle
Operating pressure: max. 350 bar

Note: These valves must be set according to the application.

Identification	Pressure setting range min. bar	Pressure setting range max. bar	Qmax L/min	A mm	B mm	Screw-in housing	Screw-in thread	AF mm	Tightening torque N-m	Level control ratio	Weight kg
HK CB BY LHN	70	280	20	50,0	35,0	HK EBAM/HK EBAT/HK EBY/HK EBYS/HK YEU	T-11A	22	50,0	1:2	0,5
HK CB CA LIN	25	105	60	50,0	35,0	HK EBAM/HK EBAT/HK EBY/HK EBYS/HK YEU	T-11A	22	50,0	1:3	0,5
HK CB CA LHN	70	280	60	50,0	35,0	HK EBAM/HK EBAT/HK EBY/HK EBYS/HK YEU	T-11A	22	50,0	1:3	0,5
HK CB EA LIN	25	105	120	61,0	35,0	HK BCV/HK BCVS/HK BCW/HK BCWS/HK YAV	T-2A	28	65,0	1:3	0,5
HK CB EA LHN	70	280	120	61,0	35,0	HK BCV/HK BCVS/HK BCW/HK BCWS/HK YAV	T-2A	28	65,0	1:3	0,5

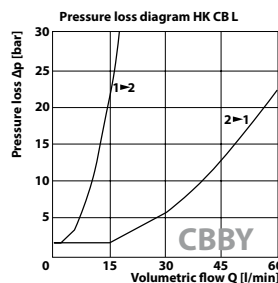
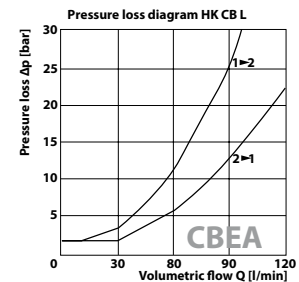
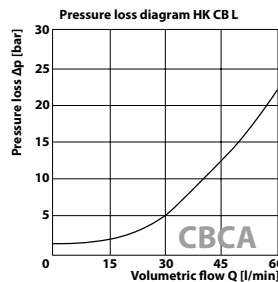
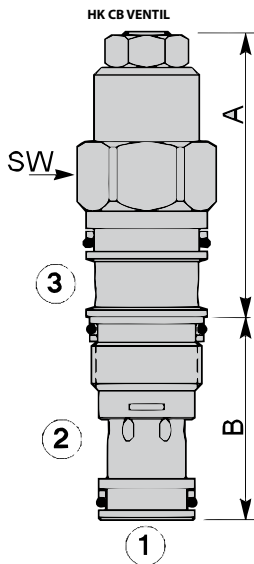

Web: <http://cat.hansa-flex.com/en/HKCBL>

Accessories:

- HK GEH BC - Valve housing for cartridge valve T-2A
- HK GEH EBA - Housing sandwich plate with measurement connctn. for cart. valve T-11A
- HK GEH EBY - Housing sandwich plate with measurement connctn. for cart. valve T-11A
- HK GEH YA - Valve housing for cartridge valve T-2A
- HK GEH YE - Valve housing for cartridge valve T-11A
- HK HR SUN - Hand wheel for cartridge valve SUN

Flow divider / combiner FDCV

flow divider / combiner - pressure compensated
 Division ratio 50 % : 50 %
 Max. deviation at $Q > 40\% Q_{max}$: $\pm 2.5\%$
Design: pressure-compensated
Operating pressure: max. 350 bar

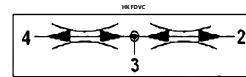

Note: The greatest division accuracy is achieved in the range of the max. intake volumetric flow.
 These valves can also be used for combining volumetric flows. (see circuit symbol)
 Tightening torque for valve size 10 with Alu housing: 47-54 Nm
 Tightening torque for valve size 10 with Steel housing: 74-81 Nm

Identification	Qon min. L/min	Qon max. L/min	Screw-in housing	Screw-in thread	Weight kg
HK FDCV 10 N0 11	3,5	7,0	HK GEH 12 C1040 ST	SAE 10/2 7/8"-14UNF-2B	0,14
HK FDCV 10 N0 22	7,5	15,0	HK GEH 12 C1040 ST	SAE 10/2 7/8"-14UNF-2B	0,14
HK FDCV 10 N0 33	11,0	22,0	HK GEH 12 C1040 ST	SAE 10/2 7/8"-14UNF-2B	0,14
HK FDCV 10 N0 44	15,0	30,0	HK GEH 12 C1040 ST	SAE 10/2 7/8"-14UNF-2B	0,14
HK FDCV 10 N0 66	22,5	45,0	HK GEH 12 C1040 ST	SAE 10/2 7/8"-14UNF-2B	0,14
HK FDCV 10 N0 88	30,0	60,0	HK GEH 12 C1040 ST	SAE 10/2 7/8"-14UNF-2B	0,14

Qein - intake volumetric flow

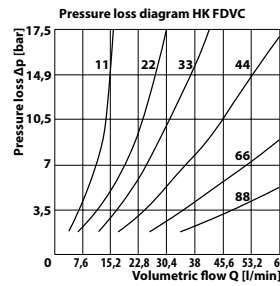
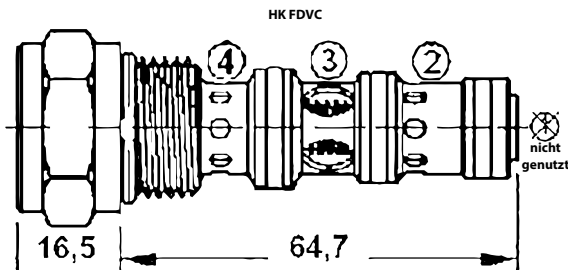

Web: <http://cat.hansa-flex.com/en/HKFDCV>

Accessories:
 HK GEH 40 AL - Housing for flow divider SAE 3-way aluminium

HK FS

Flow divider / combiner FS

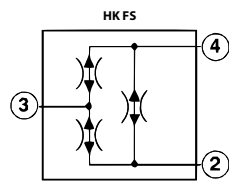

Δp at max nominal flow = 20 bar
 Same accuracy when dividing or combining the oil flows
 Division accuracy in % of total oil flow at connection 3:
 HKFSBS at 12l/min = 50% \pm 2.5%;
 HKFSBS at 2.5l/min = 50% \pm 4.5%;
 HKFSCS at 30l/min = 50% \pm 2.5%;
 HKFSCS at 6l/min = 50% \pm 4.5%;
 At $Q < Q_{min}$ the division accuracy is indeterminate
Design: pressure-compensated
Operating pressure: max. 350 bar

Identification	Volumetric flow min. L/min	Volumetric flow max. L/min	A mm	B mm	Screw-in housing	Screw-in thread	AF mm	Tightening torque N-m	Weight kg
HK FS BS XAN	2,5	12,0	19,0	85,0	HK MMU/HK MMUS/HK MMV/HK MMVS/HK MBJ M	T-31A	22	50,0	0,5
HK FS CS XAN	6,0	30,0	19,0	85,0	HK MMU/HK MMUS/HK MMV/HK MMVS/HK MBJ M	T-31A	22	50,0	0,5

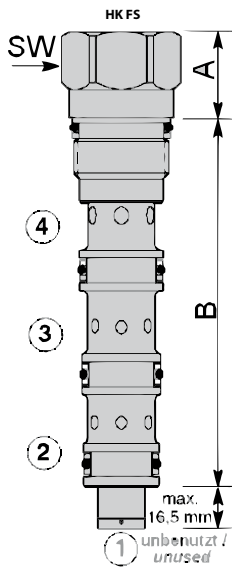

Web: <http://cat.hansa-flex.com/en/HKFS>

Accessories:

- HK GEH MM - Valve housing for cartridge valve T-31A
- HK GEH MBJ - Housing sandwich plate for cartridge valve T-31A

2-way directional flow control valve PCFC

Setting via setscrew
max. deviation: 5%

Only adjust valves in depressurized state!

Design: pressure-compensated

Operating pressure: max. 300 bar

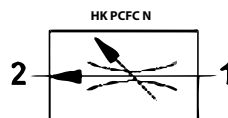

Note: These valves must be set according to the application.

Tightening torque for valve size 08 with Alu housing: 34-41 Nm

Tightening torque for valve size 08 with Steel housing: 47-54 Nm

Tightening torque for valve size 10 with Alu housing: 47-54 Nm

Tightening torque for valve size 10 with Steel housing: 74-81 Nm

Tightening torque for valve size 12 with Alu housing: 74-81 Nm

Tightening torque for valve size 12 with Steel housing: 95-102 Nm

Identification	Q min. Q max.		A	B	Screw-in housing	Screw-in thread	Setting range with Qon		Weight
	L/min	L/min					min. L/min	max. L/min	
HK PCFC 08 NS0 02	8	22	41,0	28,0	HK GEH 38 C 0820	SAE 8/2 3/4"-16UNF-2B	4,0	8,0	0,17
HK PCFC 08 NS0 03	11	22	41,0	28,0	HK GEH 38 C 0820	SAE 8/2 3/4"-16UNF-2B	5,5	11,0	0,17
HK PCFC 08 NS0 05	19	22	41,0	28,0	HK GEH 38 C 0820	SAE 8/2 3/4"-16UNF-2B	9,5	19,0	0,17
HK PCFC 10 NS0 08	30	45	48,3	32,5	HK GEH 38 C1020	SAE 10/2 7/8"-14UNF-2B	15,0	30,0	0,17
HK PCFC 12 NS0 15	57	90	49,8	44,5	HK GEH 12 C1220/HK GEH 34 C1220	SAE 12/2 1.1/16"-12UNF-2B	28,5	57,0	0,17
HK PCFC 12 NS0 20	76	90	49,8	44,5	HK GEH 12 C1220/HK GEH 34 C1220	SAE 12/2 1.1/16"-12UNF-2B	38,0	76,0	0,17

Q_{ein} - intake volumetric flow Q_{max} - max intake volumetric flow Q_{min} - min. volumetric flow for control function

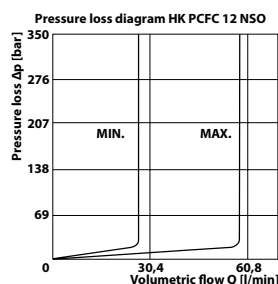
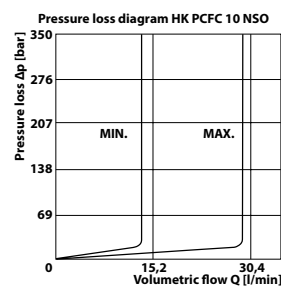
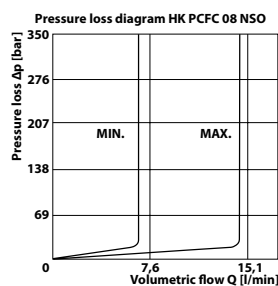
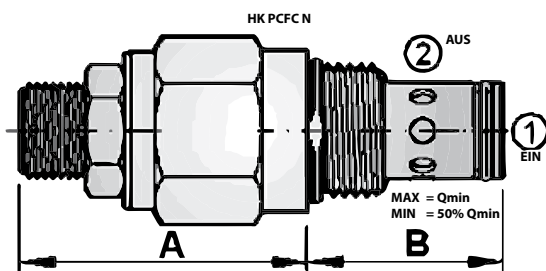

Web: <http://cat.hansa-flex.com/en/HKPCFC>

Accessories:

HK GEH 20 AL - Aluminium housing for SAE 2-way cartridge valve

HK GEH 20 GGG - GGG40 housing for SAE 2-way cartridge valve

HK FD

2-way directional control valve FD

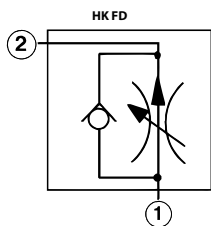

Design: with non-return valve for free return (pre-loading 0.7bar), pressure relieved valve spindle for easy adjustment
Operating pressure: max. 350 bar

Identification	Volumetric flow min. L/min	Volumetric flow max. L/min	A mm	B mm	Screw-in housing	Screw-in thread	AF mm	Tightening torque N-m	Weight kg
HK FD BA LCN	0,4	4,0	52,0	35,0	HK GAU/HK GAUS/HK GAV/HK GBA/HK GBY	T-13A	22	50,0	0,5
HK FD BA LBN	0,4	8,0	52,0	35,0	HK GAU/HK GAUS/HK GAV/HK GBA/HK GBY	T-13A	22	50,0	0,5
HK FD BA LAN	0,4	23,0	52,0	35,0	HK GAU/HK GAUS/HK GAV/HK GBA/HK GBY	T-13A	22	50,0	0,5
HK FD CB LBN	1,0	11,5	62,0	41,0	HK DAV/HK DAVS	T-5A	28	65,0	0,5
HK FD CB LWN	1,0	30,0	62,0	41,0	HK DAV/HK DAVS	T-5A	28	65,0	0,5
HK FD CB LAN	1,0	45,0	62,0	41,0	HK DAV/HK DAVS	T-5A	28	65,0	0,5

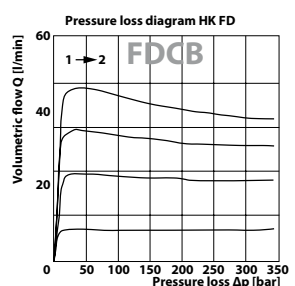
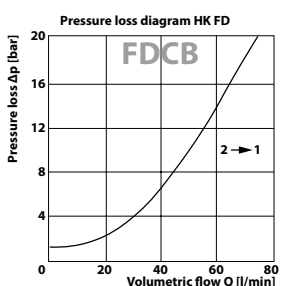
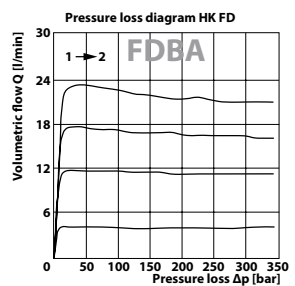
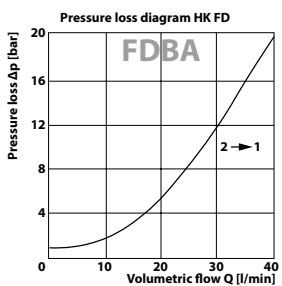
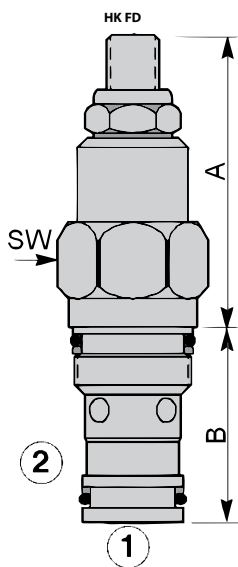

Web: <http://cat.hansa-flex.com/en/HKFD>

Accessories:

- HK GEH DA - Valve housing for cartridge valve T-5A
- HK GEH GA - Valve housing for cartridge valve T-13A
- HK GEH GBA - Housing sandwich plate with measurement connctn. for cart. valve T-13A
- HK GEH GBY - Housing sandwich plate with measurement connctn. for cart. valve T-13A
- HK HR SUN - Hand wheel for cartridge valve SUN

3-way flow control valve BFCV

max. deviation: 5%

Setting via setscrew

residual oil flow at outlet 2 can be pressurized.

Only adjust valves in depressurized state!

Design: pressure-compensated

Operating pressure: max. 300 bar

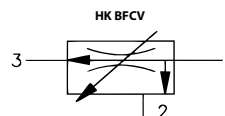

Note: These valves must be set according to the application.

Tightening torque for valve size 08 with Alu housing: 34-41 Nm

Tightening torque for valve size 08 with Steel housing: 47-54 Nm

Tightening torque for valve size 10 with Alu housing: 47-54 Nm

Tightening torque for valve size 10 with Steel housing: 74-81 Nm

Tightening torque for valve size 12 with Alu housing: 74-81 Nm

Tightening torque for valve size 12 with Steel housing: 95-102 Nm

Identification	Q min. Q max.		A	B	Screw-in housing	Screw-in thread	Setting range with Qon		Weight
	L/min	L/min					min. L/min	max. L/min	
HK BFCV 08 NS0 02	8	22	41,0	40,0	HK GEH 38 C 0830	SAE 08/3 3/4"-16UNF-2B	4,0	8,0	0,2
HK BFCV 08 NS0 03	11	22	41,0	40,0	HK GEH 38 C 0830	SAE 08/3 3/4"-16UNF-2B	5,5	11,0	0,2
HK BFCV 08 NS0 05	19	22	41,0	40,0	HK GEH 38 C 0830	SAE 08/3 3/4"-16UNF-2B	9,5	19,0	0,2
HK BFCV 10 NS0 08	30	45	48,3	47,3	HK GEH 38 C1030	SAE 10/3 7/8"-14UNF-2B	15,0	30,0	0,2
HK BFCV 12 NS0 15	57	76	49,8	67,3	HK GEH 12 C1230	SAE 12/3 1.1/16"-12UNF-2B	28,5	57,0	0,2
HK BFCV 12 NS0 18	68	76	49,8	67,3	HK GEH 12 C1230	SAE 12/3 1.1/16"-12UNF-2B	34,0	68,0	0,2

Q_{ein} - intake volumetric flow Q_{max} - max intake volumetric flow Q_{min} - min. volumetric flow for control function

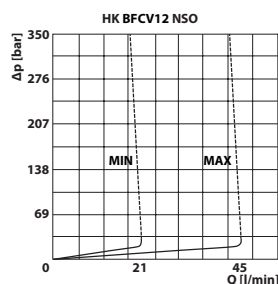
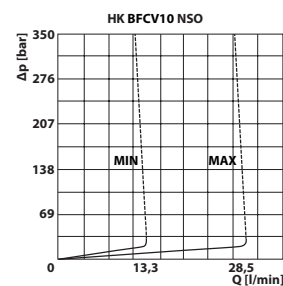
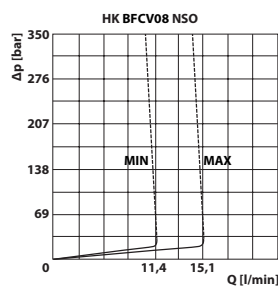
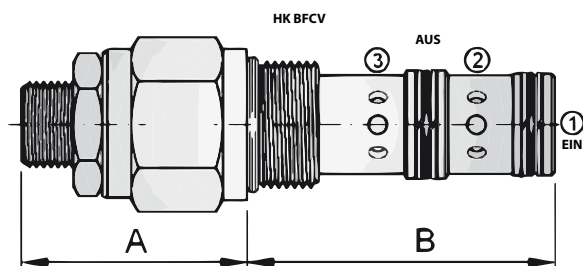

Web: <http://cat.hansa-flex.com/en/HKBFCV>

Accessories:

HK GEH 30 AL - Aluminium housing for SAE 3-way cartridge valve

HK GEH 30 GGG - GGG40 housing for SAE 3-way cartridge valve

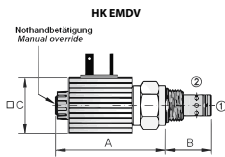
HK EMDV
2/2-way solenoid-controlled seat valve EMDV

Scope of supply: with coil, without plug
 Operating pressure: max. 350 bar

Note: Caution!

Type HKEMDV10N01/NC1 valves are not seat valves
 Please use rectifier plug HKSP669 for HKEMDV08***230AC valves
 Tightening torque for valve size 08 with Alu housing: 34-41 Nm
 Tightening torque for valve size 08 with Steel housing: 47-54 Nm
 Tightening torque for valve size 10 with Alu housing: 47-54 Nm
 Tightening torque for valve size 10 with Steel housing: 74-81 Nm
 Tightening torque for valve size 12 with Alu housing: 74-81 Nm
 Tightening torque for valve size 12 with Steel housing: 95-102 Nm

Identification	Circuit diagram	Control	Volumetric flow max.	A	B	C	Screw-in housing	Screw-in thread	Design	Rated voltage/current type	Weight kg
				L/min	mm	mm					
HK EMDV 08 N08 12DC		pilot-controlled	38,0	78,7	27,9	34,3	HK GEH 38 C 0820	SAE 8/2 3/4"-16UNF-2B	(1)	12 VDC	0,36
HK EMDV 08 N08 24DC		pilot-controlled	38,0	78,7	27,9	34,3	HK GEH 38 C 0820	SAE 8/2 3/4"-16UNF-2B	(1)	24 VDC	0,36
HK EMDV 08 N08 230AC		pilot-controlled	38,0	78,7	27,9	34,3	HK GEH 38 C 0820	SAE 8/2 3/4"-16UNF-2B	(1)	230 VAC	0,36
HK EMDV 08 NC8 12DC		pilot-controlled	38,0	71,1	27,9	34,3	HK GEH 38 C 0820	SAE 8/2 3/4"-16UNF-2B	(1)	12 VDC	0,36
HK EMDV 08 NC8 24DC		pilot-controlled	38,0	71,1	27,9	34,3	HK GEH 38 C 0820	SAE 8/2 3/4"-16UNF-2B	(1)	24 VDC	0,36
HK EMDV 08 NC8 230AC		pilot-controlled	38,0	71,1	27,9	34,3	HK GEH 38 C 0820	SAE 8/2 3/4"-16UNF-2B	(1)	230 VAC	0,36
HK EMDV 08 NC3 12DC		directly controlled	19,0	78,7	27,9	34,3	HK GEH 38 C 0820	SAE 8/2 3/4"-16UNF-2B	(1)	12 VDC	0,41
HK EMDV 08 NC3 24DC		directly controlled	19,0	78,7	27,9	34,3	HK GEH 38 C 0820	SAE 8/2 3/4"-16UNF-2B	(1)	24 VDC	0,41
HK EMDV 08 NC3 230AC		directly controlled	19,0	78,7	27,9	34,3	HK GEH 38 C 0820	SAE 8/2 3/4"-16UNF-2B	(1)	230 VAC	0,41
HK EMDV 10 N01 12DC		directly controlled	30,0	93,2	32,5	45,2	HK GEH 38 C1020	SAE 10/2 7/8"-14UNF-2B	(2)	12 VDC	0,88
HK EMDV 10 N01 24DC		directly controlled	30,0	93,2	32,5	45,2	HK GEH 38 C1020	SAE 10/2 7/8"-14UNF-2B	(2)	24 VDC	0,88
HK EMDV 10 N01 230AC		directly controlled	30,0	93,2	32,5	45,2	HK GEH 38 C1020	SAE 10/2 7/8"-14UNF-2B	(2)	230 VAC	0,88
HK EMDV 10 NC1 12DC		directly controlled	30,0	93,2	32,5	45,2	HK GEH 38 C1020	SAE 10/2 7/8"-14UNF-2B	(2)	12 VDC	0,88
HK EMDV 10 NC1 24DC		directly controlled	30,0	93,2	32,5	45,2	HK GEH 38 C1020	SAE 10/2 7/8"-14UNF-2B	(2)	24 VDC	0,88
HK EMDV 10 NC1 230AC		directly controlled	30,0	93,2	32,5	45,2	HK GEH 38 C1020	SAE 10/2 7/8"-14UNF-2B	(2)	230 VAC	0,88
HK EMDV 12 N04 12DC		pilot-controlled	136,0	96,8	44,4	45,2	HK GEH 12 C1220/HK GEH 34 C1220	SAE 12/2 1.1/16"-12UNF-2B	(2)	12 VDC	0,90
HK EMDV 12 N04 24DC		pilot-controlled	136,0	96,8	44,4	45,2	HK GEH 12 C1220/HK GEH 34 C1220	SAE 12/2 1.1/16"-12UNF-2B	(2)	24 VDC	0,90

(1) without manual emergency operation (2) with manual emergency operation →

(Continued)

HK EMDV

2/2-way solenoid-controlled seat valve EMDV

Identification	Circuit diagram	Control	Volumetric flow max.	A	B	C	Screw-in housing	Screw-in thread	Design	Rated voltage/current type	Weight kg
				L/min	mm	mm					
HK EMDV 12 N04 230AC W		pilot-controlled	136,0	96,8	44,4	45,2	HK GEH 12 C1220/HK GEH 34 C1220	SAE 12/2 1.1/16"-12UNF-2B	(2)	230 VAC	0,90
HK EMDV 12 NC4 12DC W		pilot-controlled	136,0	96,8	44,4	45,2	HK GEH 12 C1220/HK GEH 34 C1220	SAE 12/2 1.1/16"-12UNF-2B	(1)	12 VDC	0,90
HK EMDV 12 NC4 24DC W		pilot-controlled	136,0	96,8	44,4	45,2	HK GEH 12 C1220/HK GEH 34 C1220	SAE 12/2 1.1/16"-12UNF-2B	(1)	24 VDC	0,90
HK EMDV 12 NC4 230AC W		pilot-controlled	136,0	96,8	44,4	45,2	HK GEH 12 C1220/HK GEH 34 C1220	SAE 12/2 1.1/16"-12UNF-2B	(1)	230 VAC	0,90

(1) without manual emergency operation (2) with manual emergency operation

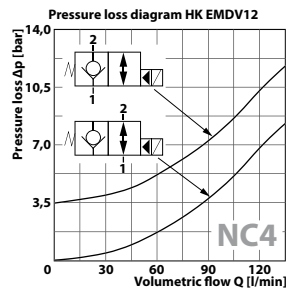
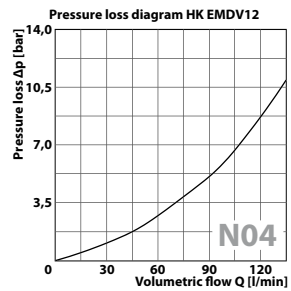
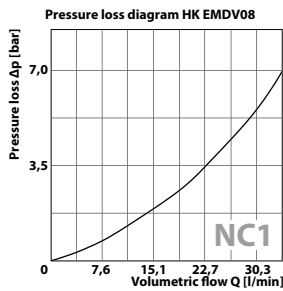
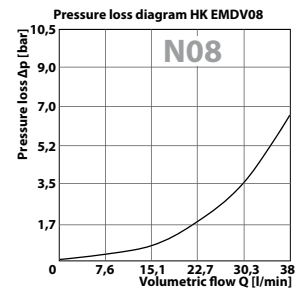
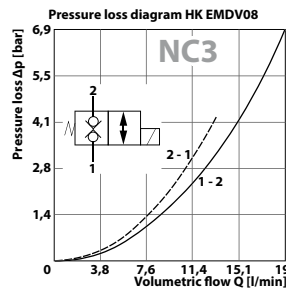
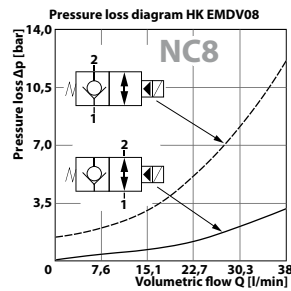
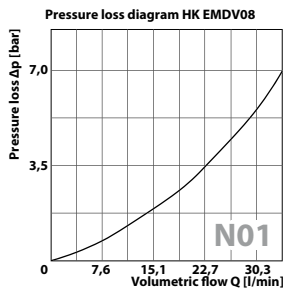
 Web: <http://cat.hansa-flex.com/en/HKEMDV>
Accessories:

HK GEH 20 AL - Aluminium housing for SAE 2-way cartridge valve

HK GEH 20 GGG - GGG40 housing for SAE 2-way cartridge valve

HK SP DIN 43650 - Electrical plug for solenoid coil DIN 43650 / ISO 4400

HK SP EMDV - Coil for cartridge valve EMDV

HK DTDA

2/2-way solenoid-operated directional control valve DTDA

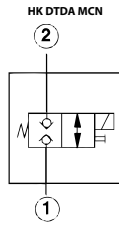

Max. leakage 0.7cm³/min at 250 bar and 32cSt

Design: direct-controlled, with manual emergency operation

Scope of supply: without coil or plug

Operating pressure: max. 350 bar

Ordering information: Please order solenoid coil separately (see accessories)

Identification	Circuit diagram	Volumetric flow min. L/min	A mm	B mm	C mm	Screw-in housing	Screw-in thread	AF mm	Tightening torque N-m	Design	Weight kg
HK DTDA MCN		40,0	89,0	35,0	37,0	HK GAU/HK GAUS/HK GAV	T-13A	22	48,0	power-off closed, double locking	0,5
HK DTDA MHN		40,0	89,0	35,0	37,0	HK GAU/HK GAUS/HK GAV	T-13A	22	48,0	power-off open, double locking	0,5

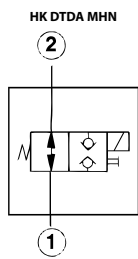
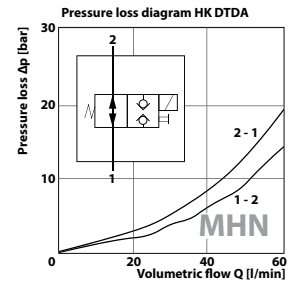
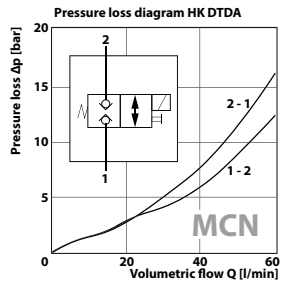
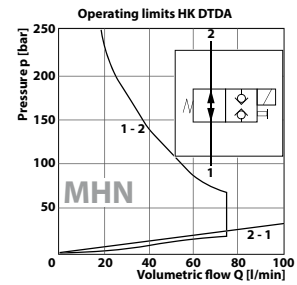
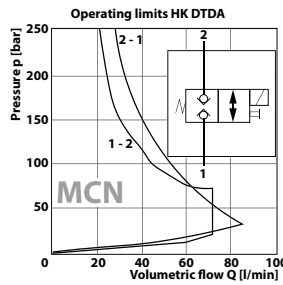
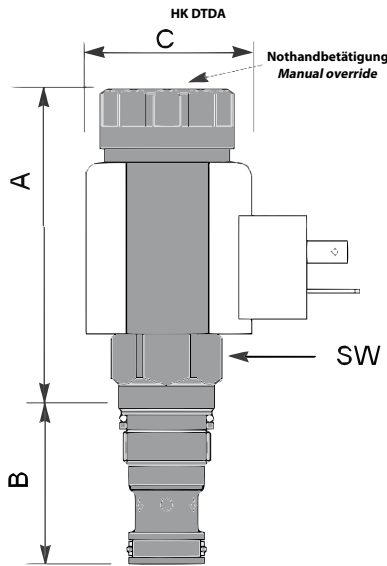

Web: <http://cat.hansa-flex.com/en/HKDTDA>

Accessories:

HK SP 770 - Coil for cartridge valve SUN

HK GEH GA - Valve housing for cartridge valve T-13A

HK GEH GBA - Housing sandwich plate with measurement connctn. for cart. valve T-13A

HK GEH GBY - Housing sandwich plate with measurement connctn. for cart. valve T-13A

HK GEH MBJ - Housing sandwich plate for cartridge valve T-31A

HK GEH 20 AL

Aluminium housing for SAE 2-way cartridge valve

Material: Aluminium AlZnMgCu1.5
Operating pressure: max. 250 bar
Surface: anodised



Identification	Valve bore	A	Connection 1,3	C	D	E	F	G	H	I	L	M	Weight
				mm	mm	mm	mm	mm	mm	mm	mm	mm	
HK GEH 38 C0820	C0820	UNF 3/4" -16	G 3/8"	50	50	29	20	13,5	12	6	9,0	35	0,2
HK GEH 38 C1020	C1020	UNF 7/8" -14	G 3/8"	60	60	39	24	19,0	15	7	7,5	45	0,4
HK GEH 34 C1020	C1020	UNF 7/8" -14	G 3/4"	60	60	44	24	21,5	15	7	7,5	45	0,6
HK GEH 12 C1220	C1220	UNF 1 1/16" -12	G 1/2"	80	80	49	34	26,0	18	9	10,0	60	0,8
HK GEH 34 C1220	C1220	UNF 1 1/16" -12	G 3/4"	80	80	49	34	26,0	18	9	10,0	60	0,8

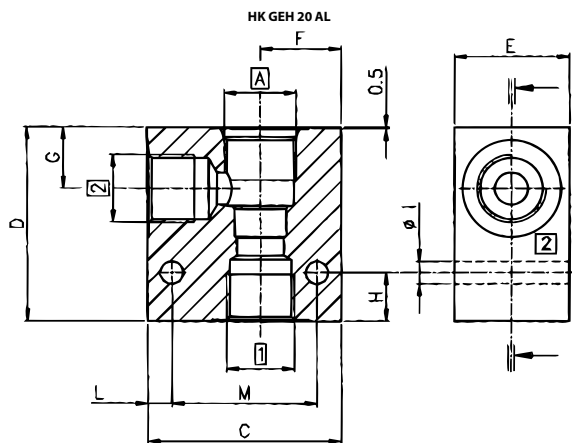

Web: <http://cat.hansa-flex.com/en/HKGEH20AL>

Accessory for following products:

HK EMDV - 2/2-way solenoid-controlled seat valve EMDV

HK RVPS - Pressure relief valve RVPS

HK PCFC - 2-way directional flow control valve PCFC

HK GEH 30 AL

Aluminium housing for SAE 3-way cartridge valve



Material: Aluminium AlZnMgCu1.5
Operating pressure: max. 250 bar
Surface: anodised

1

Identification	Valve bore	A	Connection 1,3	Connection 3	C	D	E	F	G	G1	H	I	L	M	Weight
					mm	mm	mm	mm	mm	mm	mm	mm	mm	mm	
HK GEH 38 C0830	C0830	UNF 3/4" -16	G 3/8"	G 3/8"	60	65	29	30,0	29,5	15,0	15	7	7,5	44	0,2
HK GEH 38 C1030	C1030	UNF 7/8" -14	G 3/8"	G 3/8"	70	75	39	35,5	34,5	18,5	15	7	7,5	54	0,5
HK GEH 12 C1230	C1230	UNF 1 1/16" -12	G 3/4"	G 1/2"	80	100	39	40,0	53,5	28,5	18	9	10,0	59	0,9

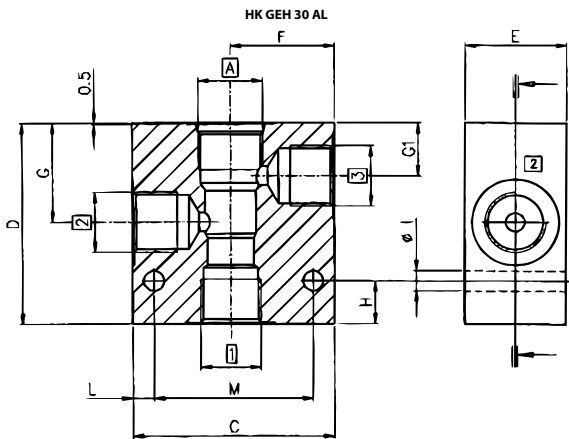

Web: <http://cat.hansa-flex.com/en/HKGEH30AL>

Accessory for following products:

HK BFCV - 3-way flow control valve BFCV

HK PRRS - 3-way pressure reduction valve PRRS

HK GEH 40 AL

Housing for flow divider SAE 3-way aluminium

Material: Aluminium AlZnMgCu1.5
Operating pressure: max. 250 bar
Surface: anodised



Identification	Valve bore	A	Connection ^{2,3,5}	C mm	D mm	E mm	F mm	G mm	G1 mm	G2 mm	H mm	I mm	L mm	M mm	Weight kg
HK GEH 12 C1040 ST	C1040	UNF 7/8" -14	G 1/2"	70	90	39	35	18,5	34	50	12	7	7,5	54	0,6

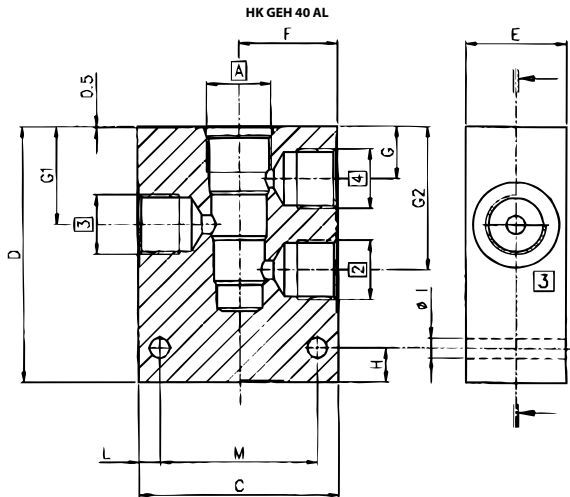

Web: <http://cat.hansa-flex.com/en/HKGEH40AL>

Accessory for following products:
 HK FDCV - Flow divider / combiner FDCV

HK GEH 20 GGG

GGG40 housing for SAE 2-way cartridge valve



Material: GGG 40
Operating pressure: max. 350 bar
Surface: galvanised

1

Identification	Valve bore	A	Connection 1,3	C	D	E	F	G	H	I	L	M	Weight
				mm	mm	mm	mm	mm	mm	mm	mm	mm	mm
HK GEH 38 C0820 GGG	C0820	UNF 3/4" -16	G 3/8"	50	50	29	20	13,5	12	6	9,0	35	0,4
HK GEH 38 C1020 GGG	C1020	UNF 7/8" -14	G 3/8"	60	60	40	24	19,0	15	7	7,5	45	0,8
HK GEH 34 C1020 GGG	C1020	UNF 7/8" -14	G 3/4"	60	60	44	24	21,5	15	7	7,5	45	1,7
HK GEH 12 C1220 GGG	C1220	UNF 1 1/16" -12	G 1/2"	80	80	50	34	26,0	18	9	10,0	60	0,9
HK GEH 34 C1220 GGG	C1220	UNF 1 1/16" -12	G 3/4"	80	80	50	34	26,0	18	9	10,0	60	1,7

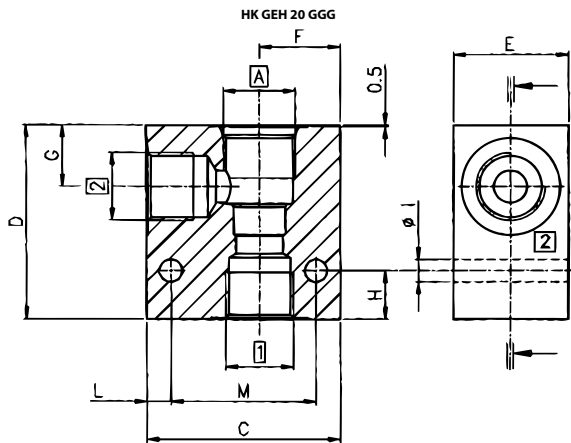

Web: <http://cat.hansa-flex.com/en/HKGEH20GGG>

Accessory for following products:

- HK EMDV - 2/2-way solenoid-controlled seat valve EMDV
- HK RVPS - Pressure relief valve RVPS
- HK PCFC - 2-way directional flow control valve PCFC

HK GEH 30 GGG

GGG40 housing for SAE 3-way cartridge valve

Material: GGG 40
Operating pressure: max. 350 bar
Surface: galvanised

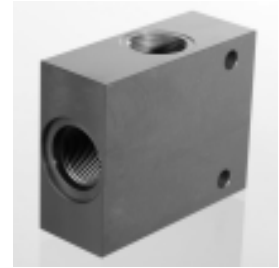

Identification	Valve bore	A	Connection 1,3	Connection 3	C	D	E	F	G	G1	H	I	L	M	Weight
					mm	mm	mm	mm	mm	mm	mm	mm	mm	mm	kg
HK GEH 38 C0830 GGG	C0830	UNF 3/4" -16	G 3/8"	G 3/8"	60	65	29	30,0	29,5	15,0	15	7	7,5	44	0,6
HK GEH 38 C1030 GGG	C1030	UNF 7/8" -14	G 3/8"	G 3/8"	70	75	39	35,5	34,5	18,5	15	7	7,5	54	1,2
HK GEH 12 C1230 GGG	C1230	UNF 1 1/16" -12	G 3/4"	G 1/2"	80	100	39	40,0	53,5	28,5	18	9	10,0	59	1,7

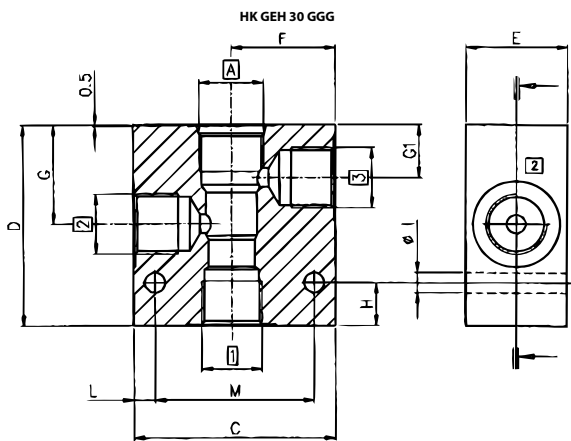

Web: <http://cat.hansa-flex.com/en/HKGEH30GGG>

Accessory for following products:
 HK BFCV - 3-way flow control valve BFCV
 HK PRRS - 3-way pressure reduction valve PRRS

HK GEH ZP NG

Steel housing sandwich plate NG6/10 for SAE 2-way cartridge valve

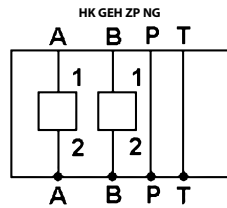

Sealing form: O-ring seal
Design: functions in channel A + B, optional sealing of a cartridge bore with blank plug (*)
Material: Steel
Operating pressure: max. 350 bar

Note: (*) matching blank plugs
 for SAE08/2 : PLUG O 08
 for SAE10/2 : PLUG O 10
 for SAE12/2 : PLUG O 12

Identification	Connection	C mm	D mm	E mm	F mm	G mm	for valve type	Weight kg
HK ZP NG6 C08 AB	Cetop 03 NG 6	45	50	25	100	45	HK EMDV08 - SAE8/2 3/4-16UNF-2B	1,3
HK ZP NG6 C10 AB	Cetop 03 NG 6	45	50	25	100	45	HK EMDV10 - SAE10/2 7/8-14UNF-2B	1,2
HK ZP NG10 C12 AB	Cetop 05 NG 10	75	50	31	160	52	HK EMDV12 - SAE12/2 1.1/16-12UNF-2B	2,1

HK GEH ZP NG6, NG10

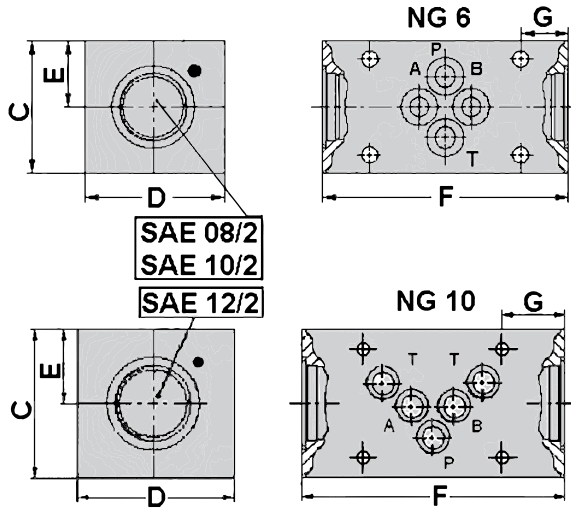

Web: <http://cat.hansa-flex.com/en/HKGEHZPNG>

HK GEH ZP16 DB ST

Steel housing ZP NG16 for SAE 2-way pressure relief valve

Sealing form: O-ring seal
Material: Steel
Operating pressure: max. 350 bar

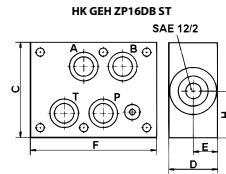

Identification	Connection	C	D	E	F	H	acts in channel	for valve type	Weight kg
		mm	mm	mm	mm	mm			
HK GEH ZP16 DB 12 AT	Cetop 07 NG 16	90	40	20	120	45	A + T	HK RVPS12NS0 - SAE12/2 1 1/16-12UNF-2B	3,4
HK GEH ZP16 DB 12 PT	Cetop 07 NG 16	90	40	20	120	45	P + T	HK RVPS12NS0 - SAE12/2 1 1/16-12UNF-2B	3,4

Web: <http://cat.hansa-flex.com/en/HKGEHZP16DBST>

HK GEH ZP25 DB ST

Steel housing ZP NG25 for SAE 2-way pressure relief valve

Sealing form: O-ring seal
Material: Steel
Operating pressure: max. 350 bar

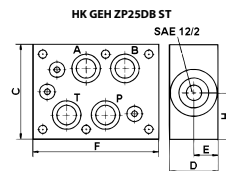

Identification	Connection	C	D	E	F	H	acts in channel	for valve type	Weight kg
		mm	mm	mm	mm	mm			
HK GEH ZP25 DB 12 AT	Cetop 08 NG 25	120	50	23	160	60	A + T	HK RVPS12NS0 - SAE12/2 1 1/16-12UNF-2B	11,2
HK GEH ZP25 DB 12 PT	Cetop 08 NG 25	120	50	23	160	60	P + T	HK RVPS12NS0 - SAE12/2 1 1/16-12UNF-2B	11,2

Web: <http://cat.hansa-flex.com/en/HKGEHZP25DBST>

HK GEH BC

Valve housing for cartridge valve T-2A



Material: Aluminium, Steel
Operating pressure: up to 350 bar

1

Identification	Connection 1,3	Connection 3	Operating pressure	Valve bore	Material	for valve type	Weight kg
HK BCV	G 1/2"	G 1/4"	max. 210 bar	T-2A	Aluminium	HK CKEB/HK CBEA	0,5
HK BCV S	G 1/2"	G 1/4"	max. 350 bar	T-2A	Steel	HK CKEB/HK CBEA	1,4
HK BCW	G 3/4"	G 1/4"	max. 210 bar	T-2A	Aluminium	HK CKEB/HK CBEA	0,5
HK BCW S	G 3/4"	G 1/4"	max. 350 bar	T-2A	Steel	HK CKEB/HK CBEA	1,4

HK GEH BC

Einschraubbohrung T-2A
Cartridge borehole T-2A

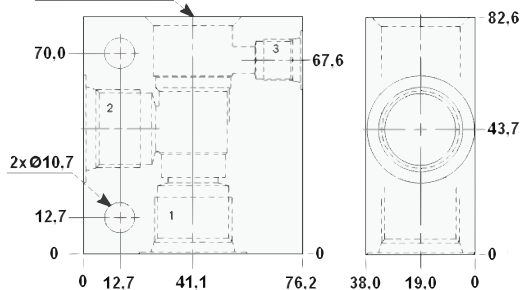

Web: <http://cat.hansa-flex.com/en/HKGEHBC>

Accessory for following products:

- HK CB L - Overcentre valve CB
- HK CK XCN - Non-return valve CK

HK GEH CA

Valve housing for cartridge valve T-3A

Material: Aluminium, Steel
Operating pressure: up to 350 bar



1

Identification	Connection 1,3	Operating pressure	Valve bore	Material	for valve type	Weight kg
HK CAV	G 1/2"	max. 210 bar	T-3A	Aluminium	HK RDFA/HK RPGC	0,5
HK CAV S	G 1/2"	max. 350 bar	T-3A	Steel	HK RDFA/HK RPGC	1,4
HK CAW	G 3/4"	max. 210 bar	T-3A	Aluminium	HK RDFA/HK RPGC	0,5
HK CAW S	G 3/4"	max. 350 bar	T-3A	Steel	HK RDFA/HK RPGC	1,4

HK GEH CA

Einschraubbohrung T-3A
Cartridge borehole T-3A

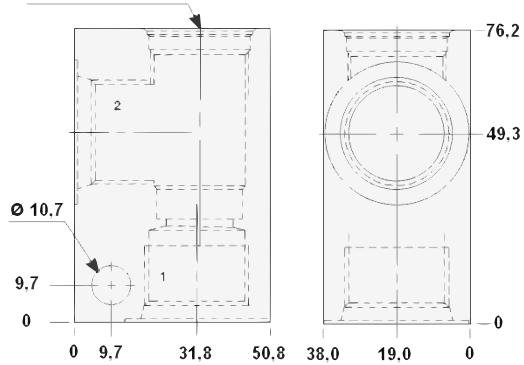

Web: <http://cat.hansa-flex.com/en/HKGEHCA>

Accessory for following products:

HK RD - Pressure relief valve RD

HK RP - Pressure relief valve RP

HK GEH DA

Valve housing for cartridge valve T-5A



Material: Aluminium, Steel
Operating pressure: up to 350 bar

1

Identification	Connection 1,3	Operating pressure	Valve bore	Material	for valve type	Weight kg
HK DAV	G 1/2"	max. 210 bar	T-5A	Aluminium	HK FDCB	0,5
HK DAV S	G 1/2"	max. 350 bar	T-5A	Steel	HK FDCB	1,4

HK GEH DA

Einschraubbohrung T-5A
Cartridge borehole T-5A

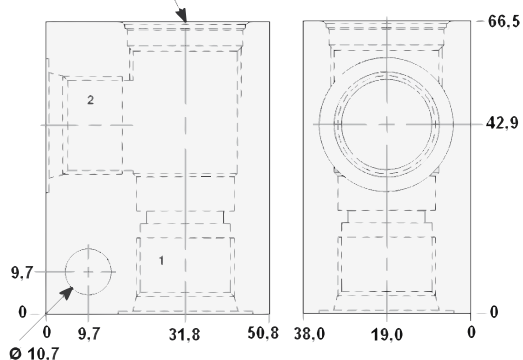

Web: <http://cat.hansa-flex.com/en/HKGEHDA>

Accessory for following products:
 HK FD - 2-way directional control valve FD

HK GEH EC

Valve housing for cartridge valve T-11A

Material: Aluminium, Steel
Operating pressure: up to 350 bar



Identification	Connection 1,3	Connection 3	Operating pressure	Valve bore	Material	for valve type	Weight kg
HK ECU	G 3/8"	G 1/4"	max. 210 bar	T-11A	Aluminium	HK CBCA/HK CKBK	0,5
HK ECU S	G 3/8"	G 1/4"	max. 350 bar	T-11A	Steel	HK CBCA/HK CKBK	1,4

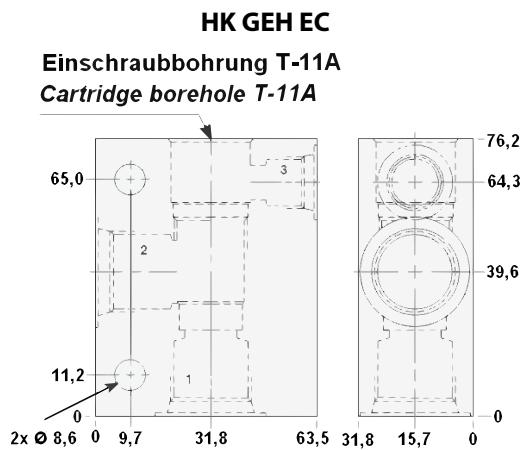

Web: <http://cat.hansa-flex.com/en/HKGEHEC>

Accessory for following products:
 HK CB L - Overcentre valve CB
 HK CK XCN - Non-return valve CK

HK GEH FA

Valve housing for cartridge valve T-10A



Material: Aluminium, Steel
Operating pressure: up to 350 bar

1

Identification	Connection 1,3	Operating pressure	Valve bore	Material	for valve type	Weight kg
HK FAU	G 3/8"	max. 210 bar	T-10A	Aluminium	HK RPEC/HK RDDA	0,5
HK FAU S	G 3/8"	max. 350 bar	T-10A	Steel	HK RPEC/HK RDDA	1,4
HK FAV	G 1/2"	max. 210 bar	T-10A	Aluminium	HK RPEC/HK RDDA	0,5
HK FAV S	G 1/2"	max. 350 bar	T-10A	Steel	HK RPEC/HK RDDA	1,4

HK GEH FA

Einschraubbohrung T-10A
Cartridge borehole T-10A

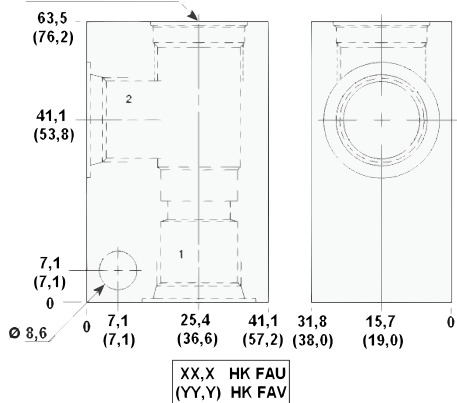

Web: <http://cat.hansa-flex.com/en/HKGEHFA>

Accessory for following products:

- HK RP - Pressure relief valve RP
- HK RD - Pressure relief valve RD

HK GEH GA

Valve housing for cartridge valve T-13A

Material: Aluminium, Steel
Operating pressure: up to 350 bar



Identification	Connection 1,3	Operating pressure	Valve bore	Material	for valve type	Weight kg
HK GAU	G 3/8"	max. 210 bar	T-13A	Aluminium	HK DTDA/HK FDDBA	0,5
HK GAU S	G 3/8"	max. 350 bar	T-13A	Steel	HK DTDA/HK FDDBA	1,4
HK GAV	G 1/2"	max. 210 bar	T-13A	Aluminium	HK DTDA/HK FDDBA	0,5

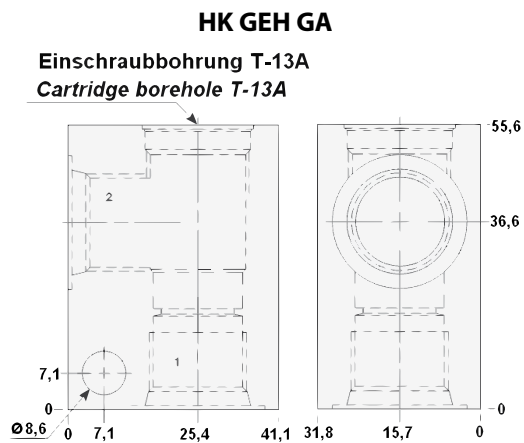

Web: <http://cat.hansa-flex.com/en/HKGEHGA>

Accessory for following products:
 HK DTDA - 2/2-way solenoid-operated directional control valve DTDA
 HK FD - 2-way directional control valve FD

HK GEH MM

Valve housing for cartridge valve T-31A



Material: Aluminium, Steel
Operating pressure: up to 350 bar

1

Identification	Connection ^{2,3,5}	Operating pressure	Valve bore	Material	for valve type	Weight kg
HK MMU	G 3/8"	max. 210 bar	T-31A	Aluminium	HK FSBS/HK FSCS	0,7
HK MMU S	G 3/8"	max. 350 bar	T-31A	Steel	HK FSBS/HK FSCS	1,6
HK MMV	G 1/2"	max. 210 bar	T-31A	Aluminium	HK FSBS/HK FSCS	0,7
HK MMV S	G 1/2"	max. 350 bar	T-31A	Steel	HK FSBS/HK FSCS	1,6

HK GEH MM

Einschraubbohrung T-31A

Cartridge borehole T-31A

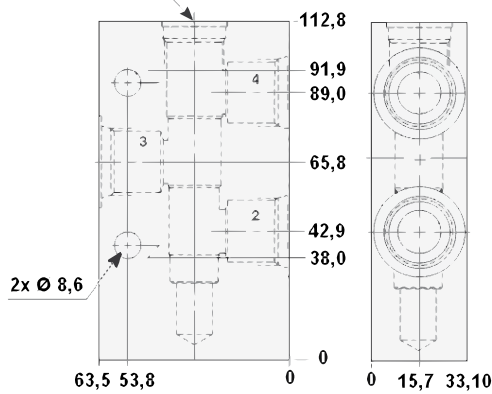

Web: <http://cat.hansa-flex.com/en/HKGEHMM>

Accessory for following products:
 HK FS - Flow divider / combiner FS

HK GEH YA

Valve housing for cartridge valve T-2A

Connections C1, C2, V1, V2: G1/2"

Material: Aluminium

Operating pressure: max. 210 bar



Identification	Valve bore	for valve type	Weight kg
HK YAV	T-2A	HK CBEA	0,7

HK GEH YA

Einschraubbohrung T-2A
Cartridge borehole T-2A

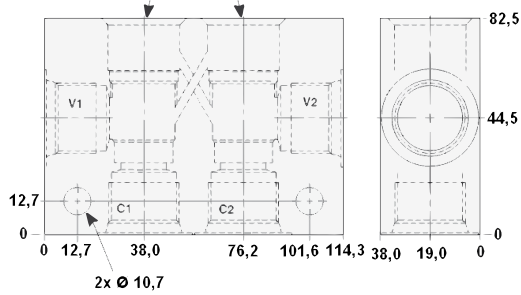

Web: <http://cat.hansa-flex.com/en/HKGEHYA>

Accessory for following products:
HK CB L - Overcentre valve CB

HK GEH YE

Valve housing for cartridge valve T-11A



Connections C1, C2, V1, V2: G1/2"
Material: Aluminium
Operating pressure: max. 210 bar

1

Identification	Valve bore	for valve type	Weight kg
HK YEU	T-11A	HK CBCA	0,5

HK GEH YE

**Einschraubbohrung T-11A
 Cartridge borehole T-11A**

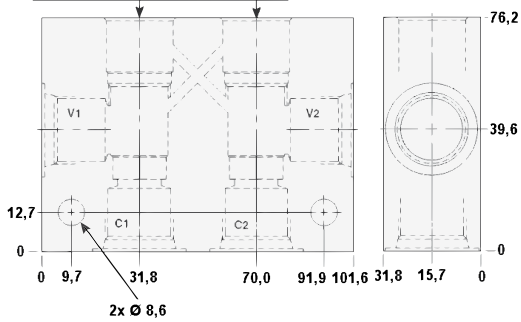

Web: <http://cat.hansa-flex.com/en/HKGEHYE>

Accessory for following products:
 HK CB L - Overcentre valve CB

Housing sandwich plate with measurement connctn. for cart. valve T-11A

Including measurement connection G1/4"

Material: Aluminium, Steel

Operating pressure: up to 350 bar



Identification	Connection	Operating pressure	Valve bore	Material	acts in channel	for valve type	Weight kg
HK EBA M	Cetop 03 NG 6	max. 210 bar	T-11A	Aluminium	A / B	HK CBBY/HK CBCA	0,5
HK EBAT	Cetop 03 NG 6	max. 350 bar	T-11A	Steel	A / B	HK CBBY/HK CBCA	1,1

HK GEH EBA

Einschraubbohrung T-11A

Cartridge borehole T-11A

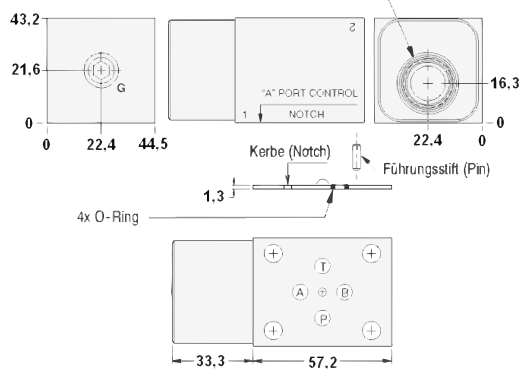

Web: <http://cat.hansa-flex.com/en/HKGEHEBA>

Accessory for following products:

HK CB L - Overcentre valve CB

HK GEH EBY

Housing sandwich plate with measurement connctn. for cart. valve T-11A



Material: Aluminium, Steel
Operating pressure: up to 350 bar

1

Identification	Connection	Operating pressure	Valve bore	Material	acts in channel	for valve type	Weight kg
HK EBY	Cetop 03 NG 6	max. 210 bar	T-11A	Aluminium	A + B	HK CBBY/HK CBCA	0,5
HK EBY S	Cetop 03 NG 6	max. 350 bar	T-11A	Steel	A + B	HK CBBY/HK CBCA	1,3

HK GEH EBY

**Einschraubbohrung T-11A
 Cartridge borehole T-11A**

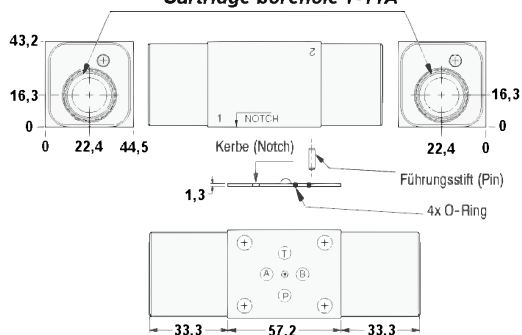

Web: <http://cat.hansa-flex.com/en/HKGEHEBY>

Accessory for following products:
 HK CB L - Overcentre valve CB

HK GEH GBA

Housing sandwich plate with measurement connctn. for cart. valve T-13A

Material: Aluminium
Operating pressure: max. 210 bar



1

Identification	Connection	Valve bore	acts in channel	for valve type	Weight kg
HK GBA	Cetop 03 NG 6	T-13A	A / B	HK FDBA	0,5

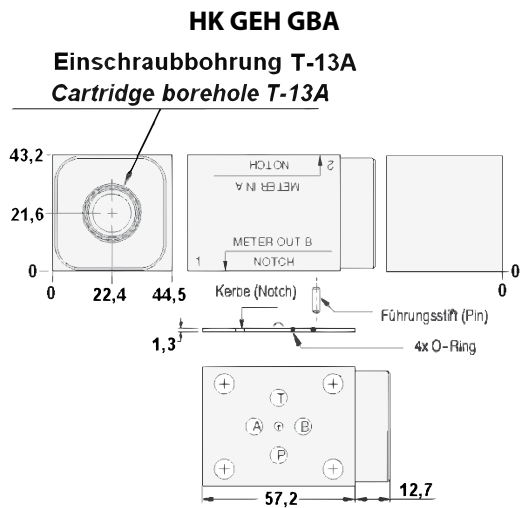

Web: <http://cat.hansa-flex.com/en/HKGEHGBA>

Accessory for following products:
 HK FD - 2-way directional control valve FD

HK GEH GBY

Housing sandwich plate with measurement connctn. for cart. valve T-13A



Material: Aluminium
Operating pressure: max. 210 bar

1

Identification	Connection	Valve bore	acts in channel	for valve type	Weight kg
HK GBY	Cetop 03 NG 6	T-13A	A + B	HK FDBA	1,1

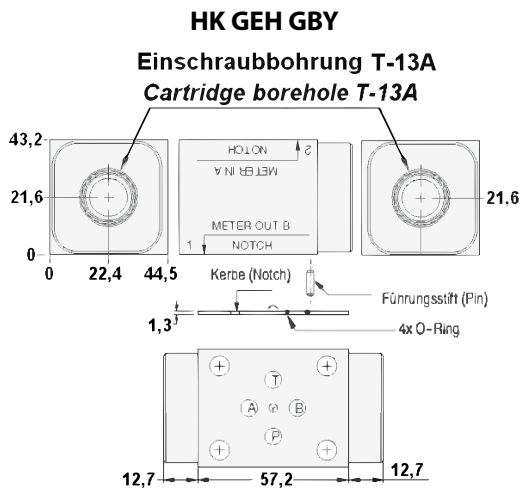

Web: <http://cat.hansa-flex.com/en/HKGEHGBY>

Accessory for following products:
 HK FD - 2-way directional control valve FD

HK GEH MBJ

Housing sandwich plate for cartridge valve T-31A

Material: Aluminium
Operating pressure: max. 210 bar



1

Identification	Connection	Valve bore	acts in channel	for valve type	Weight kg
HK MBJ M	Cetop 03 NG 6	T-31A	A / B	HK FSBS/HK FSCS	0,7

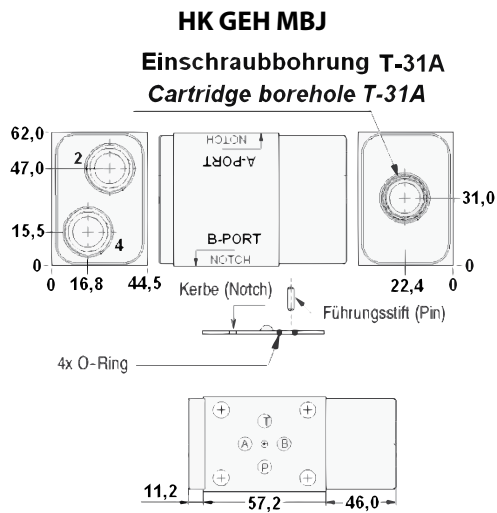

Web: <http://cat.hansa-flex.com/en/HKGEHMBJ>

Accessory for following products:
 HK FS - Flow divider / combiner FS

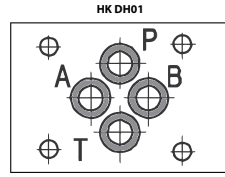
HK DH01
Hand-operated directional control valve NG6

Mechanical operation with hand lever
Hand lever mounted on side "A"

Design: 4/2-way valve or 4/3-way valve
Operating pressure: P, A, B: max. 350bar / T: max. 160bar
Volumetric flow: max. 50 l/min (note characteristic curves)
Connection: ISO/Cetop 03 size 6
Mounting: 4 pcs. socket head screw M5x50 12.9

Ordering information: Further circuits and versions available on request

Identification	Circuit diagram	Type	Overlap	Piston type	Design	Weight kg
HK DH01 20		4/2	negative (open)	0 [PB/AT]-[PA/BT]	Spring return	1,6
HK DH01 21		4/2	positive (closed)	1 [PB/AT]-[PA/BT]	Spring return	1,6
HK DH01 50		4/2	negative (open)	0 [PB/AT]-[PA/BT]	2 latching positions	1,6
HK DH01 51		4/2	positive (closed)	1 [PB/AT]-[PA/BT]	2 latching positions	1,6
HK DH01 10		4/3	negative (open)	0 [PB/AT]-[ABPT]-[PA/BT]	spring return to 0	1,6
HK DH01 11		4/3	positive (closed)	1 [PB/AT]-[A/B/P/T]-[PA/BT]	spring return to 0	1,6
HK DH01 13		4/3	positive (closed)	3 [PB/AT]-[ABT/P]-[PA/BT]	spring return to 0	1,6
HK DH01 14		4/3	negative (open)	4 [PA/BT]-[A/B/PT]-[PB/AT]	spring return to 0	1,6
HK DH01 40		4/3	negative (open)	0 [PB/AT]-[ABPT]-[PA/BT]	3 latching positions	1,6
HK DH01 41		4/3	positive (closed)	1 [PB/AT]-[A/B/P/T]-[PA/BT]	3 latching positions	1,6

Piston type example: [A/B/PT] = [A blocked / B blocked / P+T connected] →

(Continued)

HK DH01

Hand-operated directional control valve NG6

Identification	Circuit diagram	Type	Overlap	Piston type	Design	Weight kg
HK DH01 43		4/3	positive (closed)	3 [PB/AT]-[ABT/P]-[PA/BT]	3 latching positions	1,6
HK DH01 44		4/3	negative (open)	4 [PA/BT]-[A/B/PT]-[PB/AT]	3 latching positions	1,6

Piston type example: [A/B/PT] = [A blocked / B blocked / P+T connected]

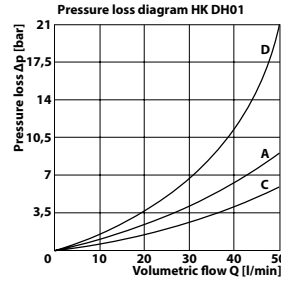
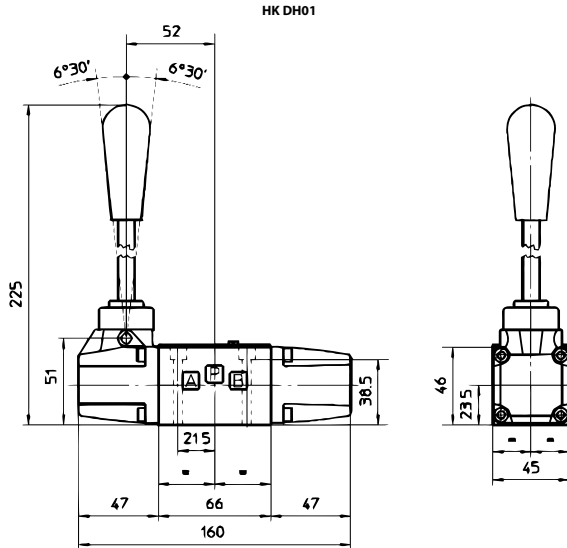

Piston types HK HK DH01

	P-A	P-B	A-T	B-T	P-T
Piston type 0	C	C	C	C	
1	A	A	A	A	
3	A	A	C	C	
4	D	D	D	D	A

Flow direction

Web: <http://cat.hansa-flex.com/en/HKDH01>

Accessories:

HK M HK DH - Screw set for NG 6 valves type HK DH / DG4V3

HK 41 C1

Hand-operated directional control valve NG6

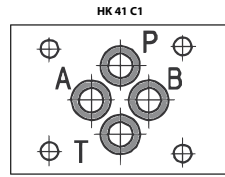

Mechanical operation with hand lever
Hand lever mounted on side "B"

- Design:** 4/2-way valve or 4/3-way valve
- Operating pressure:** P, A, B: max. 350bar / T: max. 210bar
- Volumetric flow:** max. 80 l/min (note characteristic curves)
- Connection:** ISO/Cetop 03 size 6
- Mounting:** 4 pcs. socket head screw M5x30 12.9

Ordering information: Further circuits and versions available on request

Identification	Circuit diagram	Type	Overlap	Piston type	Design	Weight kg
HK 41 3451 0204 C1		4/2	positive (closed)	51 [PB/AT]-[PA/BT]	Spring return	1,6
HK 41 3451 0905 C1		4/2	positive (closed)	51 [PB/AT]-[PA/BT]	2 latching positions	1,6
HK 41 3403 0304 C1		4/3	positive (closed)	03 [PB/AT]-[A/B/P/T]-[PA/BT]	spring return to 0	1,6
HK 41 3408 0304 C1		4/3	positive (closed)	08 [PB/AT]-[ABT/P]-[PA/BT]	spring return to 0	1,6
HK 41 3407 0304 C1		4/3	negative (open)	07 [PA/BT]-[A/B/PT]-[PB/AT]	spring return to 0	1,6
HK 41 3401 0705 C1		4/3	negative (open)	01 [PB/AT]-[ABPT]-[PA/BT]	3 latching positions	1,6
HK 41 3403 0705 C1		4/3	positive (closed)	03 [PB/AT]-[A/B/P/T]-[PA/BT]	3 latching positions	1,6
HK 41 3408 0705 C1		4/3	positive (closed)	08 [PB/AT]-[ABT/P]-[PA/BT]	3 latching positions	1,6
HK 41 3407 0705 C1		4/3	negative (open)	07 [PA/BT]-[A/B/PT]-[PB/AT]	3 latching positions	1,6

Piston type example: [A/B/PT] = [A blocked / B blocked / P+T connected]

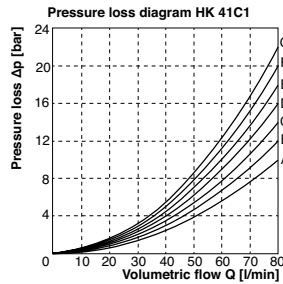
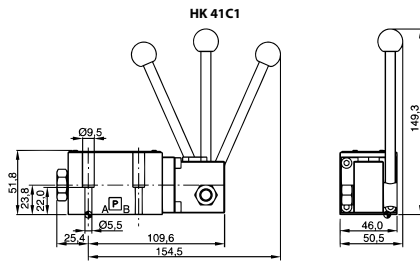

Piston types HK 41 C1 2016

Piston type	P-A	P-B	A-T	B-T	P-T
01	A	A	D	D	
03	B	B	B	B	
07	E	F	G	E	
08	B	B	C	C	
51	D	B	C	D	

Web: <http://cat.hansa-flex.com/en/HK41C1>

Accessories:
HK M HK 41 C - Set of bolts for NG6 valves type HK 41 C

Hand-operated directional control valve NG10

Mechanical operation with hand lever
Hand lever mounted on side "A"

Design: 4/2-way valve or 4/3-way valve
Operating pressure: P, A, B: max. 315bar / T: max. 160bar
Volumetric flow: max. 100 l/min (note characteristic curves)
Connection: ISO/Cetop 05 size 10
Mounting: 4 pcs. socket head screw M6x40 12.9

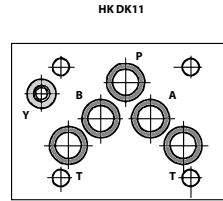

Ordering information: Further circuits and versions available on request

Identification	Circuit diagram	Type	Overlap	Piston type	Design	Weight kg
HK DK11 20		4/2	negative (open)	0 [PB/AT]-[PA/BT]	Spring return	2,5
HK DK11 21		4/2	positive (closed)	1 [PB/AT]-[PA/BT]	Spring return	2,5
HK DK11 50		4/2	negative (open)	0 [PB/AT]-[PA/BT]	2 latching positions	2,5
HK DK11 51		4/2	positive (closed)	1 [PB/AT]-[PA/BT]	2 latching positions	2,5
HK DK11 10		4/3	negative (open)	0 [PB/AT]-[ABPT]-[PA/BT]	spring return to 0	2,8
HK DK11 11		4/3	positive (closed)	1 [PB/AT]-[A/B/P/T]-[PA/BT]	spring return to 0	2,8
HK DK11 13		4/3	positive (closed)	3 [PB/AT]-[ABT/P]-[PA/BT]	spring return to 0	2,8
HK DK11 14		4/3	negative (open)	4 [PA/BT]-[A/B/PT]-[PB/AT]	spring return to 0	2,8
HK DK11 40		4/3	negative (open)	0 [PB/AT]-[ABPT]-[PA/BT]	3 latching positions	2,8
HK DK11 41		4/3	positive (closed)	1 [PB/AT]-[A/B/P/T]-[PA/BT]	3 latching positions	2,8

Piston type example: [A/B/PT] = [A blocked / B blocked / P+T connected] →

HK DK11

(Continued)

Hand-operated directional control valve NG10

Identification	Circuit diagram	Type	Overlap	Piston type	Design	Weight kg
HK DK11 43		4/3	positive (closed)	3 [PB/AT]-[ABT/P]-[PA/BT]	3 latching positions	2,8
HK DK11 44		4/3	negative (open)	4 [PA/BT]-[A/B/PT]-[PB/AT]	3 latching positions	2,8

Piston type example: [A/B/PT] = [A blocked / B blocked / P+T connected]

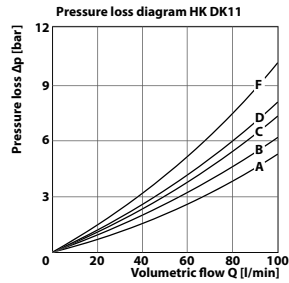
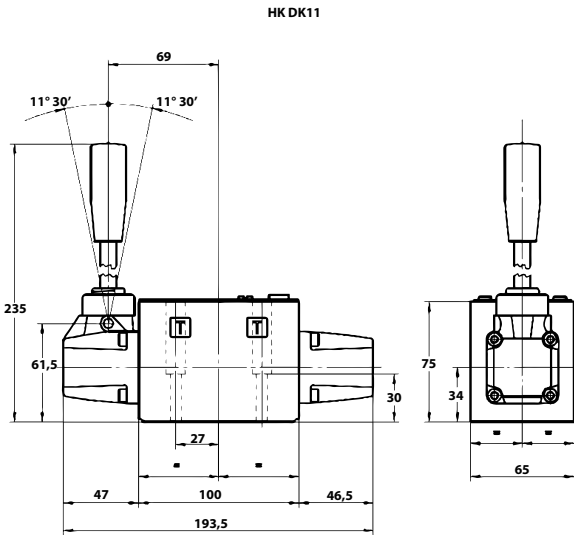

	P-A	P-B	A-T	B-T	P-T
Piston type 0	A	A	B	B	
Piston type 1	A	A	D	C	
Piston type 3	A	A	C	D	
Piston type 4	B	B	B	B	F

Flow direction

Web: <http://cat.hansa-flex.com/en/HKDK11>

Accessories:

HK M HK DK - Set of bolts for NG 10 valves types HK DK11/DKE/DG4V5

Solenoid-operated directional control valve size 6 without coil

Can only be used for DC coils
switching capacity limits see characteristic curves

- Design:** 4/2-way valve or 4/3-way valve, 5-chamber valve, with manual emergency operation, for DC coils
- Scope of supply:** without coil or plug
- Operating pressure:** P, A, B: max. 350bar / T: max. 210bar
- Volumetric flow:** max. 80 l/min (note characteristic curves)
- Connection:** ISO/Cetop 03 size 6
- Mounting:** 4 pcs. socket head screw M5x30 12.9

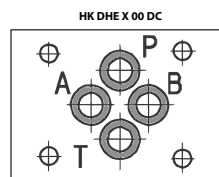

Note: Valves marked with (P) are leak oil reduced valves. With flow quantities of >70 % of the nominal values here, an increased drop in pressure is to be expected.

Leak oil reduced valves are also used as pilot valves for pilot-controlled solenoid-operated directional control valves.

When using a leak oil-reduced valve type HK DH* 0711 P*** as a pilot valve, the centre position of the main valve is overridden.

Ordering information: Further circuits and versions, volumetric flows and switching power limits on request

Identification	Circuit diagram	Type	Overlap	Piston type	Design	Weight kg
HK DHE 0610 X 00DC		4/2	negative (open)	0 [PB/AT]-[ABPT]	Spring return	1,35
HK DHE 0611 X 00DC		4/2	positive (closed)	1 [PB/AT]-[A/B/P/T]	Spring return	1,35
HK DHE 0613 X 00DC		4/2	positive (closed)	3 [PB/AT]-[ABT/P]	Spring return	1,35
HK DHE 0614 X 00DC		4/2	negative (open)	4 [PA/BT]-[A/B/PT]	Spring return	1,35
HK DHE 0630 2 X 00DC		4/2	negative (open)	0/2 [PB/AT]-[PA/BT]	Spring return	1,35
HK DHE 0631 2A X 00DC		4/2	positive (closed)	1/2 [PB/AT]-[PA/BT]	Spring return	1,35
HK DHE 0631 2 X 00DC		4/2	positive (closed)	1/2 [PB/AT]-[PA/BT]	Spring return	1,35
HK DHE 0632 2 X 00DC		4/2	positive (closed)	2/2 [PB/A/T]-[PA/B/T]	Spring return	1,35
HK DHE 0710 X 00DC		4/3	negative (open)	0 [PB/AT]-[ABPT]-[PA/BT]	spring return to 0	1,75
HK DHE 0710 9 X 00DC		4/3	negative (open)	09 [PB/AT]-[ABPT]-[PAB/T]	spring return to 0	1,75
HK DHE 0711 X 00DC		4/3	positive (closed)	1 [PB/AT]-[A/B/P/T]-[PA/BT]	spring return to 0	1,75
HK DHE 0713 X 00DC		4/3	positive (closed)	3 [PB/AT]-[ABT/P]-[PA/BT]	spring return to 0	1,75
HK DHE 0714 X 00DC		4/3	negative (open)	4 [PA/BT]-[A/B/PT]-[PB/AT]	spring return to 0	1,75
HK DHE 0714 8 X 00DC		4/3	negative (open)	4/8 [PA/BT]-[A/B/PT]-[PB/AT] spring return to 0, fine control notches		1,75
HK DHE 0714 9 X 00DC		4/3	positive (closed)	49 [PA/BT]-[A/B/PT]-[PAB/T]	spring return to 0	1,75
HK DHE 0716 X 00DC		4/3	positive (closed)	6 [PB/AT]-[AT/P/B]-[PA/BT]	spring return to 0	1,75
HK DHE 0717 X 00DC		4/3	positive (closed)	7 [PB/AT]-[A/P/BT]-[PA/BT]	spring return to 0	1,75
HK DHE 0718 X 00DC		4/3	positive (closed)	8 [PB/AT]-[PAB/T]-[PA/BT]	spring return to 0	1,75
HK DHE 0719 1 X 00DC		4/3	positive (closed)	91 [PAB/T]-[A/B/P/T]-[PA/BT]	spring return to 0	1,75
HK DHE 0751 2 X 00DC		4/2	positive (closed)	1/2 [PB/AT]-[PA/BT]	2 latching positions	1,35

Piston type example: [A/B/PT] = [A blocked / B blocked / P+T connected]

HK DHE X 00 DC

(Continued)

Solenoid-operated directional control valve size 6 without coil

Identification	Circuit diagram	Type	Overlap	Piston type	Design	Weight kg
HK DHE 0711 P X 00DC		4/3	positive (closed) 1	[PB/AT]-[A/B/P/T]-[PA/BT]	spring return to 0, reduced leak oil	1,75
HK DHE 0713 P X 00DC		4/3	positive (closed) 3	[PB/AT]-[ABT/P]-[PA/BT]	spring return to 0, reduced leak oil	1,75

Piston type example: [A/B/PT] = [A blocked / B blocked / P+T connected]

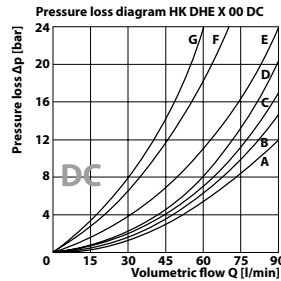
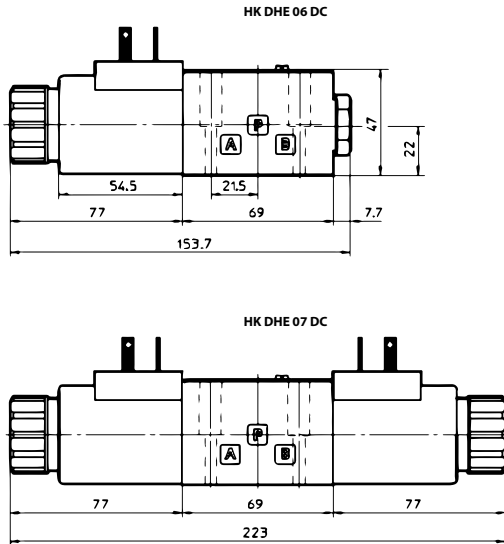

HK DHE X 00 DC

	P-A	P-B	A-T	B-T	P-T
Piston type 0, 0/1	A	A	C	C	D
0, 1/1	D	C	C	C	
3, 3/1	D	D	A	A	
4, 4/8, 5, 5/1, 09, 49, 91	F	F	G	C	E
1/2, 0/2	D	D	D	D	
6, 7	D	D	D	D	
8	A	A	E	E	
2	D	D			
2/2	F	F			

Flow direction

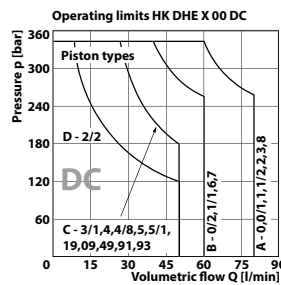

Web: <http://cat.hansa-flex.com/en/HKDHEX00DC>

Accessories:

- HK SP CO - Coil for HKDH solenoid-operated valve
- HK SP DIN 43650 - Electrical plug for solenoid coil DIN 43650 / ISO 4400
- HK M HK DH - Screw set for NG 6 valves type HK DH / DG4V3
- HK SP WPD / SP SET / 6 OE - Emergency hand operation for directional solenoid valve

Solenoid-operated directional control valve size 6 without coil

Can only be used for AC coils
switching capacity limits see characteristic curves

Design: 4/2-way valve or 4/3-way valve, 3-chamber valve, with manual emergency operation, for AC coils

Scope of supply: without coil or plug

Operating pressure: P, A, B: max. 350bar / T: max. 160bar

Volumetric flow: max. 80 l/min (note characteristic curves)

Connection: ISO/Cetop 03 size 6

Mounting: 4 pcs. socket head screw M5x30 12.9

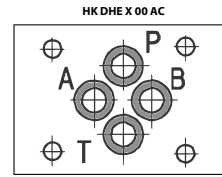

Note: Valves marked with (P) are leak oil reduced valves. With flow quantities of >70 % of the nominal values here, an increased drop in pressure is to be expected.

Leak oil reduced valves are also used as pilot valves for pilot-controlled solenoid-operated directional control valves.

When using a leak oil-reduced valve type HK DH* 0711 P*** as a pilot valve, the centre position of the main valve is overridden.

Ordering information: Further circuits and versions, volumetric flows and switching power limits on request

Identification	Circuit diagram	Type	Overlap	Piston type	Design	Weight kg
HK DHE 0610 X 00AC		4/2	negative (open)	0 [PB/AT]-[ABPT]	Spring return	1,35
HK DHE 0611 X 00AC		4/2	positive (closed)	1 [PB/AT]-[A/B/P/T]	Spring return	1,35
HK DHE 0613 X 00AC		4/2	positive (closed)	3 [PB/AT]-[ABT/P]	Spring return	1,35
HK DHE 0614 X 00AC		4/2	negative (open)	4 [PA/BT]-[A/B/PT]	Spring return	1,35
HK DHE 0630 2 X 00AC		4/2	negative (open)	0/2 [PB/AT]-[PA/BT]	Spring return	1,35
HK DHE 0631 2A 00AC		4/2	positive (closed)	1/2 [PB/AT]-[PA/BT]	Spring return	1,35
HK DHE 0631 2 X 00AC		4/2	positive (closed)	1/2 [PB/AT]-[PA/BT]	Spring return	1,35
HK DHE 0632 2 X 00AC		4/2	positive (closed)	2/2 [PB/A/T]-[PA/B/T]	Spring return	1,35
HK DHE 0710 X 00AC		4/3	negative (open)	0 [PB/AT]-[ABPT]-[PA/BT]	spring return to 0	1,75
HK DHE 0710 9 X 00AC		4/3	negative (open)	09 [PB/AT]-[ABPT]-[PAB/T]	spring return to 0	1,75
HK DHE 0711 X 00AC		4/3	positive (closed)	1 [PB/AT]-[A/B/P/T]-[PA/BT]	spring return to 0	1,75
HK DHE 0713 X 00AC		4/3	positive (closed)	3 [PB/AT]-[ABT/P]-[PA/BT]	spring return to 0	1,75
HK DHE 0714 X 00AC		4/3	negative (open)	4 [PA/BT]-[A/B/PT]-[PB/AT]	spring return to 0	1,75
HK DHE 0714 9 X 00AC		4/3	positive (closed)	49 [PA/BT]-[A/B/PT]-[PAB/T]	spring return to 0	1,75
HK DHE 0716 X 00AC		4/3	positive (closed)	6 [PB/AT]-[AT/P/B]-[PA/BT]	spring return to 0	1,75
HK DHE 0717 X 00AC		4/3	positive (closed)	7 [PB/AT]-[A/P/BT]-[PA/BT]	spring return to 0	1,75
HK DHE 0718 X 00AC		4/3	positive (closed)	8 [PB/AT]-[PAB/T]-[PA/BT]	spring return to 0	1,75
HK DHE 0719 1 X 00AC		4/3	positive (closed)	91 [PAB/T]-[A/B/P/T]-[PA/BT]	spring return to 0	1,75
HK DHE 0751 2 X 00AC		4/2	positive (closed)	1/2 [PB/AT]-[PA/BT]	2 latching positions	1,75

Piston type example: [A/B/PT] = [A blocked / B blocked / P+T connected]

HK DHE X 00 AC

(Continued)

Solenoid-operated directional control valve size 6 without coil

Identification	Circuit diagram	Type	Overlap	Piston type	Design	Weight kg
HK DHE 0711 P X 00AC		4/3	positive (closed) 1	[PB/AT]-[A/B/P/T]-[PA/BT]	spring return to 0, reduced leak oil	1,75
HK DHE 0713 P X 00AC		4/3	positive (closed) 3	[PB/AT]-[ABT/P]-[PA/BT]	spring return to 0, reduced leak oil	1,75

Piston type example: [A/B/P/T] = [A blocked / B blocked / P+T connected]

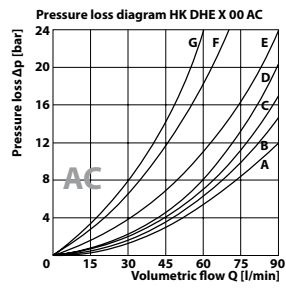
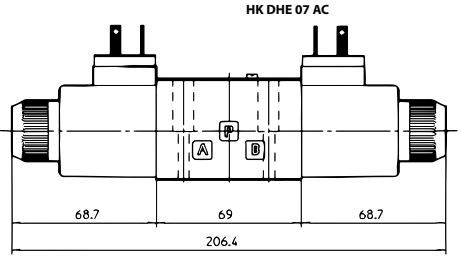
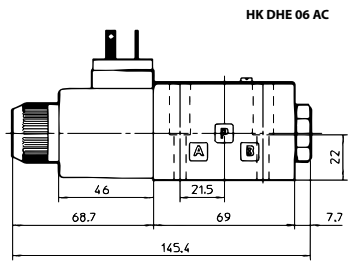

	P-A	P-B	A-T	B-T	P-T
Piston type 0, 0/1	A	A	C	C	D
0, 1/1	D	C	C	C	
3, 3/1	D	D	A	A	
4, 4/8, 5, 5/1, 09, 49, 91	F	F	G	C	E
1/2, 0/2	D	D	D	D	
6, 7	D	D	D	D	
8	A	A	E	E	
2	D	D			
2/2	F	F			

Flow direction

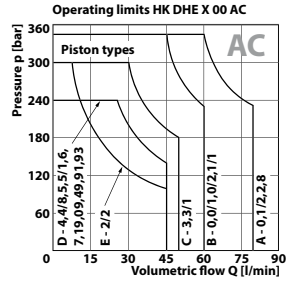

Web: <http://cat.hansa-flex.com/en/HKDHEX00AC>

Accessories:

- HK SP CO - Coil for HKDH solenoid-operated valve
- HK SP DIN 43650 - Electrical plug for solenoid coil DIN 43650 / ISO 4400
- HK M HK DH - Screw set for NG 6 valves type HK DH / DG4V3
- HK SP WPD / SP SET / 6 OE - Emergency hand operation for directional solenoid valve

Solenoid-operated directional control valve NG6

switching capacity limits see characteristic curves

Design: 4/2-way valve or 4/3-way valve, with manual emergency operation

Scope of supply: with coil, without plug

Operating pressure: P, A, B: max. 350bar / T: max. 210bar

Volumetric flow: max. 80 l/min (note characteristic curves)

Connection: ISO/Cetop 03 size 6

Mounting: 4 pcs. socket head screw M5x30 12.9

protection class: IP 65

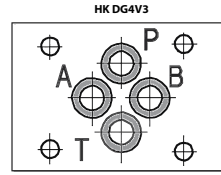

Ordering information: Further circuits and versions, volumetric flows and switching power limits on request

Identification	Circuit diagram	Type	Piston type	Rated voltage/ current type	Overlap	Design	Weight kg
HK DG4V3 0A VM U 12DC		4/2	0A [PB/AT]-[PA/BT]	12 VDC	negative (open)	Spring return	1,60
HK DG4V3 0A VM U 24DC		4/2	0A [PB/AT]-[PA/BT]	24 VDC	negative (open)	Spring return	1,60
HK DG4V3 0A VM U 110AC		4/2	0A [PB/AT]-[PA/BT]	110 VAC	negative (open)	Spring return	1,60
HK DG4V3 0A VM U 230AC		4/2	0A [PB/AT]-[PA/BT]	230 VAC 50 Hz	negative (open)	Spring return	1,60
HK DG4V3 0B VM U 12DC		4/2	0B [PB/AT]-[ABPT]	12 VDC	negative (open)	Spring return	1,60
HK DG4V3 0B VM U 24DC		4/2	0B [PB/AT]-[ABPT]	24 VDC	negative (open)	Spring return	1,60
HK DG4V3 0B VM U 110AC		4/2	0B [PB/AT]-[ABPT]	110 VAC	negative (open)	Spring return	1,60
HK DG4V3 0B VM U 230AC		4/2	0B [PB/AT]-[ABPT]	230 VAC 50 Hz	negative (open)	Spring return	1,60
HK DG4V3 2A VM U 12DC		4/2	2A [PB/AT]-[PA/BT]	12 VDC	positive (closed)	Spring return	1,60
HK DG4V3 2A VM U 24DC		4/2	2A [PB/AT]-[PA/BT]	24 VDC	positive (closed)	Spring return	1,60
HK DG4V3 2A VM U 110AC		4/2	2A [PB/AT]-[PA/BT]	110 VAC	positive (closed)	Spring return	1,60
HK DG4V3 2A VM U 230AC		4/2	2A [PB/AT]-[PA/BT]	230 VAC 50 Hz	positive (closed)	Spring return	1,60
HK DG4V3 2AL VM U 12DC		4/2	2AL [PB/AT]-[PA/BT]	12 VDC	negative (open)	Spring return	1,60
HK DG4V3 2AL VM U 24DC		4/2	2AL [PB/AT]-[PA/BT]	24 VDC	negative (open)	Spring return	1,60
HK DG4V3 2AL VM U 110AC		4/2	2AL [PB/AT]-[PA/BT]	110 VAC	negative (open)	Spring return	1,60
HK DG4V3 2AL VM U 230AC		4/2	2AL [PB/AT]-[PA/BT]	230 VAC 50 Hz	negative (open)	Spring return	1,60
HK DG4V3 2B VM U 12DC		4/2	2B [PB/AT]-[A/B/P/T]	12 VDC	positive (closed)	Spring return	1,60
HK DG4V3 2B VM U 24DC		4/2	2B [PB/AT]-[A/B/P/T]	24 VDC	positive (closed)	Spring return	1,60
HK DG4V3 2B VM U 110AC		4/2	2B [PB/AT]-[A/B/P/T]	110 VAC	positive (closed)	Spring return	1,60
HK DG4V3 2B VM U 230AC		4/2	2B [PB/AT]-[A/B/P/T]	230 VAC 50 Hz	positive (closed)	Spring return	1,60
HK DG4V3 6B VM U 12DC		4/2	6B [PB/AT]-[ABT/P]	12 VDC	positive (closed)	Spring return	1,60

Piston type example: [A/B/PT] = [A blocked / B blocked / P+T connected]

HK DG4V3

(Continued)

Solenoid-operated directional control valve NG6

Identification	Circuit diagram	Type	Piston type	Rated voltage/ current type	Overlap	Design	Weight kg
HK DG4V3 6B VM U 24DC		4/2	6B [PB/AT]-[ABT/P]	24 VDC	positive (closed)	Spring return	1,60
HK DG4V3 6B VM U 110AC		4/2	6B [PB/AT]-[ABT/P]	110 VAC	positive (closed)	Spring return	1,60
HK DG4V3 6B VM U 230AC		4/2	6B [PB/AT]-[ABT/P]	230 VAC 50 Hz	positive (closed)	Spring return	1,60
HK DG4V3 8BL VM U 12DC		4/2	8BL [PA/BT]-[A/B/PT]	12 VDC	negative (open)	Spring return	1,60
HK DG4V3 8BL VM U 24DC		4/2	8BL [PA/BT]-[A/B/PT]	24 VDC	negative (open)	Spring return	1,60
HK DG4V3 8BL VM U 110AC		4/2	8BL [PA/BT]-[A/B/PT]	110 VAC	negative (open)	Spring return	1,60
HK DG4V3 8BL VM U 230AC		4/2	8BL [PA/BT]-[A/B/PT]	230 VAC 50 Hz	negative (open)	Spring return	1,60
HK DG4V3 22A VM U 12DC		4/2	22A [PB/A/T]-[PA/B/T]	12 VDC	positive (closed)	Spring return	1,60
HK DG4V3 22A VM U 24DC		4/2	22A [PB/A/T]-[PA/B/T]	24 VDC	positive (closed)	Spring return	1,60
HK DG4V3 22A VM U 110AC		4/2	22A [PB/A/T]-[PA/B/T]	110 VAC	positive (closed)	Spring return	1,60
HK DG4V3 22A VM U 230AC		4/2	22A [PB/A/T]-[PA/B/T]	230 VAC 50 Hz	positive (closed)	Spring return	1,60
HK DG4V3 0C VM U 12DC		4/3	0C [PB/AT]-[ABPT]-[PA/BT]	12 VDC	negative (open)	spring return to 0	2,20
HK DG4V3 0C VM U 24DC		4/3	0C [PB/AT]-[ABPT]-[PA/BT]	24 VDC	negative (open)	spring return to 0	2,20
HK DG4V3 0C VM U 110AC		4/3	0C [PB/AT]-[ABPT]-[PA/BT]	110 VAC	negative (open)	spring return to 0	2,20
HK DG4V3 0C VM U 230AC		4/3	0C [PB/AT]-[ABPT]-[PA/BT]	230 VAC 50 Hz	negative (open)	spring return to 0	2,20
HK DG4V3 2C VM U 12DC		4/3	2C [PB/AT]-[A/B/P/T]-[PA/BT]	12 VDC	positive (closed)	spring return to 0	2,20
HK DG4V3 2C VM U 24DC		4/3	2C [PB/AT]-[A/B/P/T]-[PA/BT]	24 VDC	positive (closed)	spring return to 0	2,20
HK DG4V3 2C VM U 110AC		4/3	2C [PB/AT]-[A/B/P/T]-[PA/BT]	110 VAC	positive (closed)	spring return to 0	2,20
HK DG4V3 2C VM U 230AC		4/3	2C [PB/AT]-[A/B/P/T]-[PA/BT]	230 VAC 50 Hz	positive (closed)	spring return to 0	2,20
HK DG4V3 6C VM U 12DC		4/3	6C [PB/AT]-[ABT/P]-[PA/BT]	12 VDC	positive (closed)	spring return to 0	2,20
HK DG4V3 6C VM U 24DC		4/3	6C [PB/AT]-[ABT/P]-[PA/BT]	24 VDC	positive (closed)	spring return to 0	2,20
HK DG4V3 6C VM U 110AC		4/3	6C [PB/AT]-[ABT/P]-[PA/BT]	110 VAC	positive (closed)	spring return to 0	2,20
HK DG4V3 6C VM U 230AC		4/3	6C [PB/AT]-[ABT/P]-[PA/BT]	230 VAC 50 Hz	positive (closed)	spring return to 0	2,20
HK DG4V3 7C VM U 12DC		4/3	7C [PB/AT]-[PAB/T]-[PA/BT]	12 VDC	positive (closed)	spring return to 0	2,20
HK DG4V3 7C VM U 24DC		4/3	7C [PB/AT]-[PAB/T]-[PA/BT]	24 VDC	positive (closed)	spring return to 0	2,20
HK DG4V3 7C VM U 110AC		4/3	7C [PB/AT]-[PAB/T]-[PA/BT]	110 VAC	positive (closed)	spring return to 0	2,20

Piston type example: [A/B/PT] = [A blocked / B blocked / P+T connected]



(Continued)

HK DG4V3

Solenoid-operated directional control valve NG6

Identification	Circuit diagram	Type	Piston type	Rated voltage/ current type	Overlap	Design	Weight kg
HK DG4V3 7C VM U 230AC		4/3	7C [PB/AT]-[PAB/T]-[PA/BT]	230 VAC 50 Hz positive (closed)	spring return to 0	2,20	
HK DG4V3 8C VM U 12DC		4/3	8C [PA/BT]-[A/B/PT]-[PB/AT]	12 VDC	negative (open) spring return to 0	2,20	
HK DG4V3 8C VMU 24DC		4/3	8C [PA/BT]-[A/B/PT]-[PB/AT]	24 VDC	negative (open) spring return to 0	2,20	
HK DG4V3 8C VM U 110AC		4/3	8C [PA/BT]-[A/B/PT]-[PB/AT]	110 VAC	negative (open) spring return to 0	2,20	
HK DG4V3 8C VM U 230AC		4/3	8C [PA/BT]-[A/B/PT]-[PB/AT]	230 VAC 50 Hz negative (open)	spring return to 0	2,20	
HK DG4V3 2N VM U 12DC		4/2	2N [PB/AT]-[PA/BT]	12 VDC	positive (closed) 2 latching positions	1,60	
HK DG4V3 2N VM U 24DC		4/2	2N [PB/AT]-[PA/BT]	24 VDC	positive (closed) 2 latching positions	1,60	
HK DG4V3 2N VM U 110AC		4/2	2N [PB/AT]-[PA/BT]	110 VAC	positive (closed) 2 latching positions	1,60	
HK DG4V3 2N VM U 230AC		4/2	2N [PB/AT]-[PA/BT]	230 VAC 50 Hz positive (closed)	2 latching positions	1,60	

Piston type example: [A/B/PT] = [A blocked / B blocked / P+T connected]

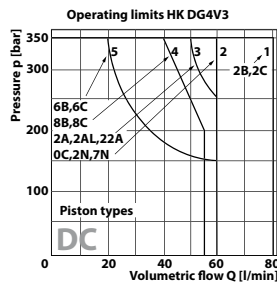
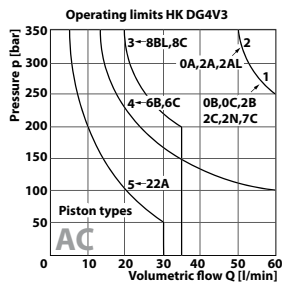
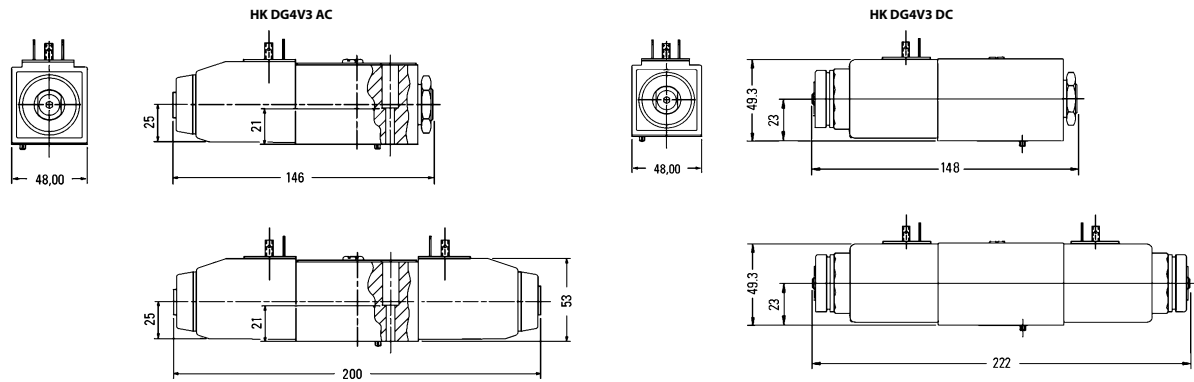

Web: <http://cat.hansa-flex.com/en/HKDG4V3>

Accessories:

- HK SP DG4V3 - Coil for HK DG4V3 solenoid-operated valve
- HK SP DIN 43650 - Electrical plug for solenoid coil DIN 43650 / ISO 4400
- HK M HK DH - Screw set for NG 6 valves type HK DH / DG4V3

HK 41 C1 (7/G/Q/R)

Solenoid-operated directional control valve NG6

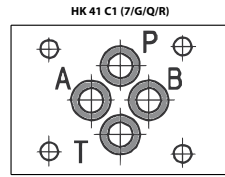

switching capacity limits see characteristic curves

Design: 4/2-way valve or 4/3-way valve, with manual emergency operation

Scope of supply: with coil, without plug

Operating pressure: P, A, B: max. 350bar / T: max. 210bar (VDC) / T: max. 140-bar (VAC)

Volumetric flow: max. 80 l/min (note characteristic curves)

Connection: ISO/Cetop 03 size 6

Mounting: 4 pcs. socket head screw M5x30 12.9

Ordering information: Further circuits and versions, volumetric flows and switching power limits on request

Identification	Circuit diagram	Type	Rated voltage/ current type	Overlap	Piston type	Design	Weight kg
HK 41 3151 0101 C1 R		4/2	12 VDC	positive (closed)	51 [PB/AT]-[PA/BT]	Spring return	1,5
HK 41 3151 0101 C1 Q		4/2	24 VDC	positive (closed)	51 [PB/AT]-[PA/BT]	Spring return	1,5
HK 41 3151 0101 C1 G		4/2	205 VDC	positive (closed)	51 [PB/AT]-[PA/BT]	Spring return	1,5
HK 41 3151 0101 C1 7		4/2	230 VAC 50 Hz	positive (closed)	51 [PB/AT]-[PA/BT]	Spring return	1,5
HK 41 3111 0101 C1 R		4/2	12 VDC	negative (open)	11 [PB/AT]-[PA/BT]	Spring return	1,5
HK 41 3111 0101 C1 Q		4/2	24 VDC	negative (open)	11 [PB/AT]-[PA/BT]	Spring return	1,5
HK 41 3111 0101 C1 G		4/2	205 VDC	negative (open)	11 [PB/AT]-[PA/BT]	Spring return	1,5
HK 41 3111 0101 C1 7		4/2	230 VAC 50 Hz	negative (open)	11 [PB/AT]-[PA/BT]	Spring return	1,5
HK 41 3151 0201 C1 R		4/2	12 VDC	positive (closed)	51 [PB/AT]-[PA/BT]	Spring return	1,5
HK 41 3151 0201 C1 Q		4/2	24 VDC	positive (closed)	51 [PB/AT]-[PA/BT]	Spring return	1,5
HK 41 3151 0201 C1 G		4/2	205 VDC	positive (closed)	51 [PB/AT]-[PA/BT]	Spring return	1,5
HK 41 3151 0201 C1 7		4/2	230 VAC 50 Hz	positive (closed)	51 [PB/AT]-[PA/BT]	Spring return	1,5
HK 41 3101 0601 C1 R		4/2	12 VDC	negative (open)	01 [PB/AT]-[ABPT]	Spring return	1,5
HK 41 3101 0601 C1 Q		4/2	24 VDC	negative (open)	01 [PB/AT]-[ABPT]	Spring return	1,5
HK 41 3101 0601 C1 G		4/2	205 VDC	negative (open)	01 [PB/AT]-[ABPT]	Spring return	1,5
HK 41 3101 0601 C1 7		4/2	230 VAC 50 Hz	negative (open)	01 [PB/AT]-[ABPT]	Spring return	1,5
HK 41 3103 0601 C1 R		4/2	12 VDC	positive (closed)	03 [PB/AT]-[A/B/P/T]	Spring return	1,5
HK 41 3103 0601 C1 Q		4/2	24 VDC	positive (closed)	03 [PB/AT]-[A/B/P/T]	Spring return	1,5
HK 41 3103 0601 C1 G		4/2	205 VDC	positive (closed)	03 [PB/AT]-[A/B/P/T]	Spring return	1,5
HK 41 3103 0601 C1 7		4/2	230 VAC 50 Hz	positive (closed)	03 [PB/AT]-[A/B/P/T]	Spring return	1,5
HK 41 3108 0601 C1 R		4/2	12 VDC	positive (closed)	08 [PB/AT]-[ABT/P]	Spring return	1,5

Piston type example: [A/B/PT] = [A blocked / B blocked / P+T connected]



(Continued) HK 41 C1 (7/G/Q/R)

Solenoid-operated directional control valve NG6

Identification	Circuit diagram	Type	Rated voltage/ current type	Overlap	Piston type	Design	Weight kg
HK 41 3108 0601 C1 Q		4/2	24 VDC	positive (closed)	08 [PB/AT]-[ABT/P]	Spring return	1,5
HK 41 3108 0601 C1 G		4/2	205 VDC	positive (closed)	08 [PB/AT]-[ABT/P]	Spring return	1,5
HK 41 3108 0601 C1 7		4/2	230 VAC 50 Hz	positive (closed)	08 [PB/AT]-[ABT/P]	Spring return	1,5
HK 41 3107 0601 C1 R		4/2	12 VDC	negative (open)	07 [PA/BT]-[A/B/PT]	Spring return	1,5
HK 41 3107 0601 C1 Q		4/2	24 VDC	negative (open)	07 [PA/BT]-[A/B/PT]	Spring return	1,5
HK 41 3107 0601 C1 G		4/2	205 VDC	negative (open)	07 [PA/BT]-[A/B/PT]	Spring return	1,5
HK 41 3107 0601 C1 7		4/2	230 VAC 50 Hz	negative (open)	07 [PA/BT]-[A/B/PT]	Spring return	1,5
HK 41 3152 0101 C1 R		4/2	12 VDC	positive (closed)	52 [PB/A/T]-[PA/B/T]	Spring return	1,5
HK 41 3152 0101 C1 Q		4/2	24 VDC	positive (closed)	52 [PB/A/T]-[PA/B/T]	Spring return	1,5
HK 41 3152 0101 C1 G		4/2	205 VDC	positive (closed)	52 [PB/A/T]-[PA/B/T]	Spring return	1,5
HK 41 3152 0101 C1 7		4/2	230 VAC 50 Hz	positive (closed)	52 [PB/A/T]-[PA/B/T]	Spring return	1,5
HK 41 3201 0302 C1 R		4/3	12 VDC	negative (open)	01 [PB/AT]-[ABPT]-[PA/BT]	spring return to 0	2,1
HK 41 3201 0302 C1 Q		4/3	24 VDC	negative (open)	01 [PB/AT]-[ABPT]-[PA/BT]	spring return to 0	2,1
HK 41 3201 0302 C1 G		4/3	205 VDC	negative (open)	01 [PB/AT]-[ABPT]-[PA/BT]	spring return to 0	2,1
HK 41 3201 0302 C1 7		4/3	230 VAC 50 Hz	negative (open)	01 [PB/AT]-[ABPT]-[PA/BT]	spring return to 0	2,1
HK 41 3203 0302 C1 R		4/3	12 VDC	positive (closed) 03	[PB/AT]-[A/B/P/T]-[PA/BT]	spring return to 0	2,1
HK 41 3203 0302 C1 Q		4/3	24 VDC	positive (closed) 03	[PB/AT]-[A/B/P/T]-[PA/BT]	spring return to 0	2,1
HK 41 3203 0302 C1 G		4/3	205 VDC	positive (closed) 03	[PB/AT]-[A/B/P/T]-[PA/BT]	spring return to 0	2,1
HK 41 3203 0302 C1 7		4/3	230 VAC 50 Hz	positive (closed) 03	[PB/AT]-[A/B/P/T]-[PA/BT]	spring return to 0	2,1
HK 41 3208 0302 C1 R		4/3	12 VDC	positive (closed)	08 [PB/AT]-[ABT/P]-[PA/BT]	spring return to 0	2,1
HK 41 3208 0302 C1 Q		4/3	24 VDC	positive (closed)	08 [PB/AT]-[ABT/P]-[PA/BT]	spring return to 0	2,1
HK 41 3208 0302 C1 G		4/3	205 VDC	positive (closed)	08 [PB/AT]-[ABT/P]-[PA/BT]	spring return to 0	2,1
HK 41 3208 0302 C1 7		4/3	230 VAC 50 Hz	positive (closed)	08 [PB/AT]-[ABT/P]-[PA/BT]	spring return to 0	2,1
HK 41 3207 0302 C1 R		4/3	12 VDC	negative (open)	07 [PA/BT]-[A/B/PT]-[PB/AT]	Spring return	2,1
HK 41 3207 0302 C1 Q		4/3	24 VDC	negative (open)	07 [PA/BT]-[A/B/PT]-[PB/AT]	Spring return	2,1
HK 41 3207 0302 C1 G		4/3	205 VDC	negative (open)	07 [PA/BT]-[A/B/PT]-[PB/AT]	Spring return	2,1

Piston type example: [A/B/PT] = [A blocked / B blocked / P+T connected] →

HK 41 C1 (7/G/Q/R)

(Continued)

Solenoid-operated directional control valve NG6

Identification	Circuit diagram	Type	Rated voltage/ current type	Overlap	Piston type	Design	Weight kg
HK 41 3207 0302 C1 7		4/3	230 VAC 50 Hz	negative (open)	07 [PA/BT]-[A/B/PT]-[PB/AT]	Spring return	2,1
HK 41 3751 0902 C1 R		4/2	12 VDC	positive (closed)	51 [PB/AT]-[PA/BT]	2 latching positions	1,5
HK 41 3751 0902 C1 Q		4/2	24 VDC	positive (closed)	51 [PB/AT]-[PA/BT]	2 latching positions	1,5
HK 41 3751 0902 C1 G		4/2	205 VDC	positive (closed)	51 [PB/AT]-[PA/BT]	2 latching positions	1,5
HK 41 3751 0902 C1 7		4/2	230 VAC 50 Hz	positive (closed)	51 [PB/AT]-[PA/BT]	2 latching positions	1,5

Piston type example: [A/B/PT] = [A blocked / B blocked / P+T connected]

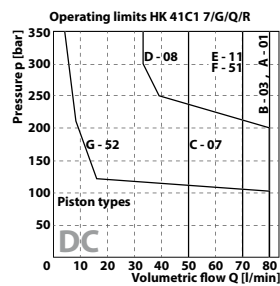
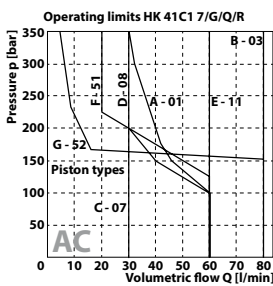
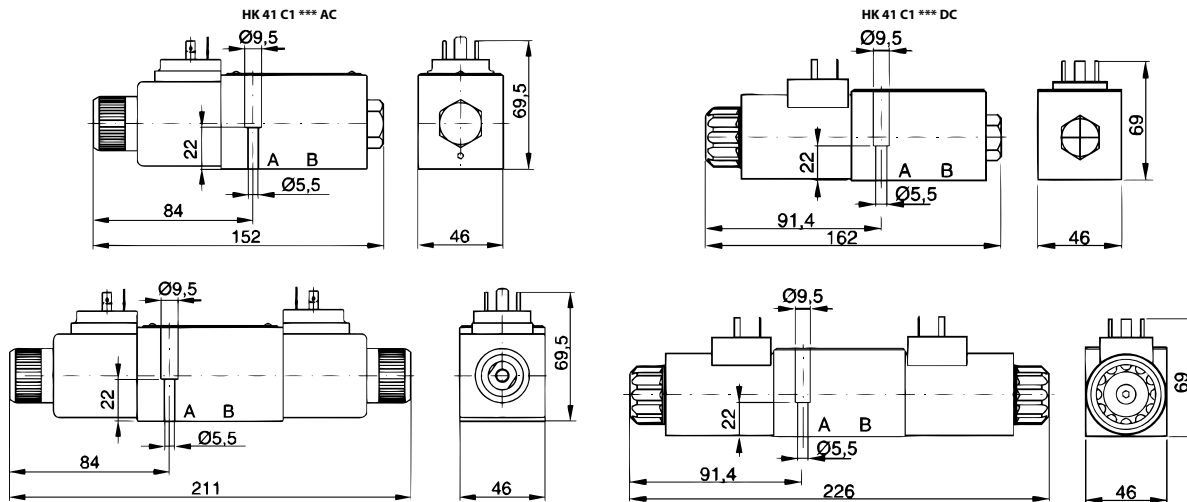

Piston types HK 41C1 7GQR

Piston type	P-A	P-B	A-T	B-T
01	A	A	D	D
03	B	B	B	B
07	E	F	G	E
08	B	B	C	C
11	B	A	B	C
51	D	B	C	D
52	C	B	-	-

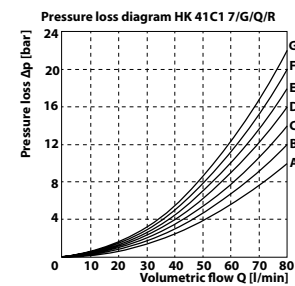

Web: <http://cat.hansa-flex.com/en/HK41C17GQR>

Accessories:

- HK SP 41C - Coil for HK41C solenoid-operated valve
- HK SP DIN 43650 - Electrical plug for solenoid coil DIN 43650 / ISO 4400
- HK M HK 41 C - Set of bolts for NG6 valves type HK 41C

HK DKE X 00 DC

Solenoid-operated directional control valve size 10 without coil

Can only be used for DC coils
switching capacity limits see characteristic curves

Design: 4/2-way valve or 4/3-way valve, 5-chamber valve, with manual emergency operation, for DC coils

Scope of supply: without coil or plug

Operating pressure: P, A, B: max. 315bar / T: max. 210bar

Volumetric flow: max. 120 l/min (note characteristic curves)

Connection: ISO/Cetop 05 size 10

Mounting: 4 pcs. socket head screw M6x40 12.9

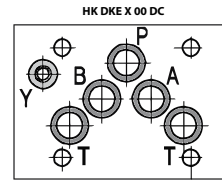

Ordering information: Further circuits and versions, volumetric flows and switching power limits on request

Identification	Circuit diagram	Type	Overlap	Piston type	Design	Weight kg
HK DKE 1 610 X00DC		4/2	negative (open)	0 [PB/AT]-[ABPT]	Spring return	3,8
HK DKE 1 611 X00DC		4/2	positive (closed)	1 [PB/AT]-[A/B/P/T]	Spring return	3,8
HK DKE 1 613 X00DC		4/2	positive (closed)	3 [PB/AT]-[ABT/P]	Spring return	3,8
HK DKE 1 631 2 X00DC		4/2	positive (closed)	1/2 [PB/AT]-[PA/BT]	Spring return	3,8
HK DKE 1 631 2 A X00DC		4/2	positive (closed)	1/2 [PB/AT]-[PA/BT]	Spring return	3,8
HK DKE 1 632 2 X00DC		4/2	positive (closed)	2/2 [PB/A/T]-[PA/B/T]	Spring return	3,8
HK DKE 1 710 X00DC		4/3	negative (open)	0 [PB/AT]-[ABPT]-[PA/BT]	spring return to 0	4,1
HK DKE 1 711 X00DC		4/3	positive (closed)	1 [PB/AT]-[A/B/P/T]-[PA/BT]	spring return to 0	4,1
HK DKE 1 713 X00DC		4/3	positive (closed)	3 [PB/AT]-[ABT/P]-[PA/BT]	spring return to 0	4,1

Piston type example: [A/B/PT] = [A blocked / B blocked / P+T connected] →

HK DKE X 00 DC

(Continued)

Solenoid-operated directional control valve size 10 without coil

Identification	Circuit diagram	Type	Overlap	Piston type	Design	Weight kg
HK DKE 1 714 X00DC		4/3	negative (open)	4 [PA/BT]-[A/B/PT]-[PB/AT]	spring return to 0	4,1
HK DKE 1 751 2 X00DC		4/2	positive (closed)	1/2 [PB/AT]-[PA/BT]	2 latching positions	3,8

Piston type example: [A/B/PT] = [A blocked / B blocked / P+T connected]

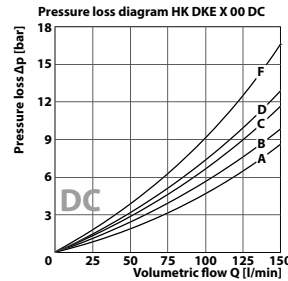
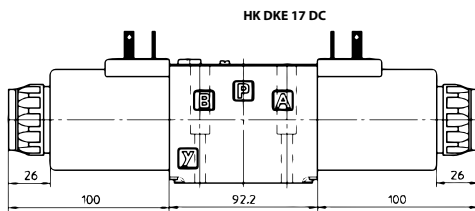
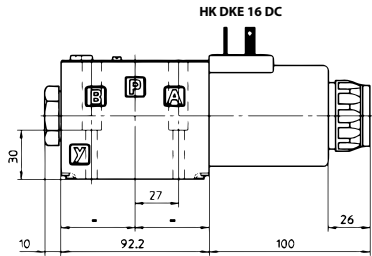

Piston types HK DKE X 00 DC

Piston type	P-A	P-B	A-T	B-T	P-T
0, 0/1, 0/2, 2/2	A	A	B	B	
1, 1/4, 1/3, 6, 8	A	A	D	C	
3, 3/1, 7	A	A	C	D	
4	B	B	B	B	F
1/2	B	C	C	B	

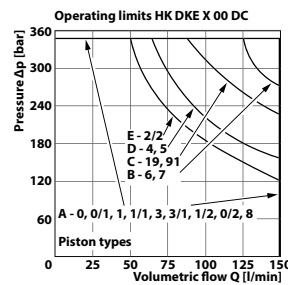

Web: <http://cat.hansa-flex.com/en/HKDKE00DC>

Accessories:

- HK SP CAE - Coil for solenoid-operated directional control valve HK DKE
- HK SP DIN 43650 - Electrical plug for solenoid coil DIN 43650 / ISO 4400
- HK M HK DK - Set of bolts for NG 10 valves types HK DK11/DKE/DG4V5
- HK SP WPD / SP SET / 6 OE - Emergency hand operation for directional solenoid valve

Solenoid-operated directional control valve size 10 without coil

Can only be used for AC coils
switching capacity limits see characteristic curves

Design: 4/2-way valve or 4/3-way valve, 3-chamber valve, with manual emergency operation, for AC coils

Scope of supply: without coil or plug

Operating pressure: P, A, B: max. 350bar / T: max. 160bar

Volumetric flow: max. 150 l/min (note characteristic curves)

Connection: ISO/Cetop 05 size 10

Mounting: 4 pcs. socket head screw M6x40 12.9

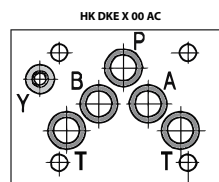

1

Ordering information: Further circuits and versions, volumetric flows and switching power limits on request

Identification	Circuit diagram	Type	Overlap	Piston type	Design	Weight kg
HK DKE 1610 X 00AC		4/2	negative (open)	0 [PB/AT]-[ABPT]	Spring return	3,6
HK DKE 1611 X 00AC		4/2	positive (closed)	1 [PB/AT]-[A/B/P/T]	Spring return	3,6
HK DKE 1613 X 00AC		4/2	positive (closed)	3 [PB/AT]-[ABT/P]	Spring return	3,6
HK DKE 1631 2 A 00AC		4/2	positive (closed)	1/2 [PB/AT]-[PA/BT]	Spring return	3,6
HK DKE 1631 2 X 00AC		4/2	positive (closed)	1/2 [PB/AT]-[PA/BT]	Spring return	3,6
HK DKE 1632 2 X 00AC		4/2	positive (closed)	2/2 [PB/A/T]-[PA/B/T]	Spring return	3,6
HK DKE 1710 X 00AC		4/3	negative (open)	0 [PB/AT]-[ABPT]-[PA/BT]	spring return to 0	4,1
HK DKE 1711 X 00AC		4/3	positive (closed)	1 [PB/AT]-[A/B/P/T]-[PA/BT]	spring return to 0	4,1
HK DKE 1713 X 00AC		4/3	positive (closed)	3 [PB/AT]-[ABT/P]-[PA/BT]	spring return to 0	4,1

Piston type example: [A/B/PT] = [A blocked / B blocked / P+T connected] →

HK DKE X 00 AC

(Continued)

Solenoid-operated directional control valve size 10 without coil

Identification	Circuit diagram	Type	Overlap	Piston type	Design	Weight kg
HK DKE 1714 X 00AC		4/3	negative (open)	4 [PA/BT]-[A/B/PT]-[PB/AT]	spring return to 0	4,1
HK DKE 1751 2 X 00AC		4/2	positive (closed)	1/2 [PB/AT]-[PA/BT]	2 latching positions	3,3

Piston type example: [A/B/PT] = [A blocked / B blocked / P+T connected]

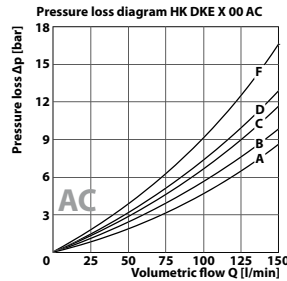
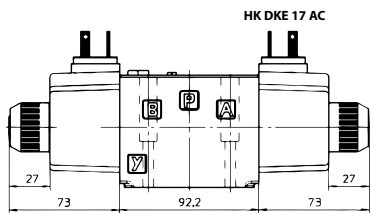
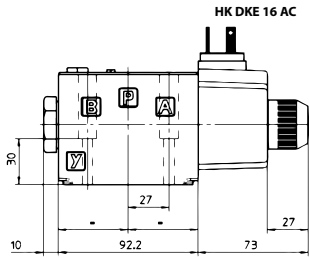

Piston types HK DKE X 00 AC

Piston type	P-A	P-B	A-T	B-T	P-T
0, 0/1, 0/2, 2/2	A	A	B	B	
1, 1/4, 1/3, 6, 8	A	A	D	C	
3, 3/1, 7	A	A	C	D	
4	B	B	B	B	F
1/2	B	C	C	B	

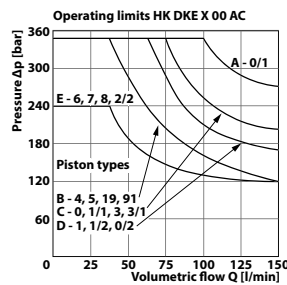

Web: <http://cat.hansa-flex.com/en/HKDKE00AC>

Accessories:

- HK SP CAE - Coil for solenoid-operated directional control valve HK DKE
- HK SP DIN 43650 - Electrical plug for solenoid coil DIN 43650 / ISO 4400
- HK M HK DK - Set of bolts for NG 10 valves types HK DK11/DKE/DG4V5
- HK SP WPD / SP SET / 6 OE - Emergency hand operation for directional solenoid valve

Solenoid-operated directional control valve NG10

switching capacity limits see characteristic curves

Design: 4/2-way valve or 4/3-way valve, with manual emergency operation

Scope of supply: with coil, without plug

Operating pressure: P, A, B: max. 315bar / T: max. 160bar (VDC) / T: max. 120bar (VAC)

Volumetric flow: max. 120 l/min (note characteristic curves)

Connection: ISO/Cetop 05 size 10

Mounting: 4 pcs. socket head screw M6x40 12.9

protection class: IP 65

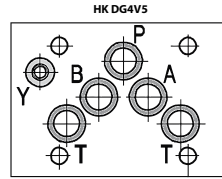

Ordering information: Further circuits and versions, volumetric flows and switching power limits on request

Identification	Circuit diagram	Type	Piston type	Rated voltage/ current type	Overlap	Design	Weight kg
HK DG4V5 0BJ VM U 12DC		4/2	0BJ [PB/AT]-[ABPT]	12 VDC	negative (open)	Spring return	3,60
HK DG4V5 0BJ VM U 24DC		4/2	0BJ [PB/AT]-[ABPT]	24 VDC	negative (open)	Spring return	3,60
HK DG4V5 0B VM U 110AC		4/2	0B [PB/AT]-[ABPT]	110 VAC	negative (open)	Spring return	3,60
HK DG4V5 0B VM U 230AC		4/2	0B [PB/AT]-[ABPT]	230 VAC 50 Hz	negative (open)	Spring return	3,60
HK DG4V5 2AJ VM U 12DC		4/2	2AJ [PB/AT]-[PA/BT]	12 VDC	positive (closed)	Spring return	3,60
HK DG4V5 2AJ VM U 24DC		4/2	2AJ [PB/AT]-[PA/BT]	24 VDC	positive (closed)	Spring return	3,60
HK DG4V5 2A VM U 110AC		4/2	2A [PB/AT]-[PA/BT]	110 VAC	positive (closed)	Spring return	3,60
HK DG4V5 2A VM U 230AC		4/2	2A [PB/AT]-[PA/BT]	230 VAC 50 Hz	positive (closed)	Spring return	3,60
HK DG4V5 2ALJ VM U 12DC		4/2	2ALJ [PB/AT]-[PA/BT]	12 VDC	negative (open)	Spring return	3,60
HK DG4V5 2ALJ VM U 24DC		4/2	2ALJ [PB/AT]-[PA/BT]	24 VDC	negative (open)	Spring return	3,60
HK DG4V5 2AL VM U 110AC		4/2	2AL [PB/AT]-[PA/BT]	110 VAC	negative (open)	Spring return	3,60
HK DG4V5 2AL VM U 230AC		4/2	2AL [PB/AT]-[PA/BT]	230 VAC 50 Hz	negative (open)	Spring return	3,60
HK DG4V5 2BJ VM U 12DC		4/2	2BJ [PB/AT]-[A/B/P/T]	12 VDC	positive (closed)	Spring return	3,60
HK DG4V5 2BJ VM U 24DC		4/2	2BJ [PB/AT]-[A/B/P/T]	24 VDC	positive (closed)	Spring return	3,60
HK DG4V5 2B VM U 110AC		4/2	2B [PB/AT]-[A/B/P/T]	110 VAC	positive (closed)	Spring return	3,60
HK DG4V5 2B VM U 230AC		4/2	2B [PB/AT]-[A/B/P/T]	230 VAC 50 Hz	positive (closed)	Spring return	3,60
HK DG4V5 6BJ VM U 12DC		4/2	6BJ [PB/AT]-[ABT/P]	12 VDC	positive (closed)	Spring return	3,60
HK DG4V5 6BJ VM U 24DC		4/2	6BJ [PB/AT]-[ABT/P]	24 VDC	positive (closed)	Spring return	3,60
HK DG4V5 6B VM U 110AC		4/2	6B [PB/AT]-[ABT/P]	110 VAC	positive (closed)	Spring return	3,60
HK DG4V5 6B VM U 230AC		4/2	6B [PB/AT]-[ABT/P]	230 VAC 50 Hz	positive (closed)	Spring return	3,60
HK DG4V5 22AJ VM U 12DC		4/2	22AJ [PB/A/T]-[PA/B/T]	12 VDC	positive (closed)	Spring return	3,60

Piston type example: [A/B/PT] = [A blocked / B blocked / P+T connected]

HK DG4V5

(Continued)

Solenoid-operated directional control valve NG10

Identification	Circuit diagram	Type	Piston type	Rated voltage/ current type	Overlap	Design	Weight kg
HK DG4V5 22AJ VM U 24DC		4/2	22AJ [PB/A/T]-[PA/B/T]	24 VDC	positive (closed)	Spring return	3,60
HK DG4V5 22A VM U 110AC		4/2	22A [PB/A/T]-[PA/B/T]	110 VAC	positive (closed)	Spring return	3,60
HK DG4V5 22A VM U 230AC		4/2	22A [PB/A/T]-[PA/B/T]	230 VAC 50 Hz	positive (closed)	Spring return	3,60
HK DG4V5 0CJ VM U 12DC		4/3	0CJ [PB/AT]-[ABPT]-[PA/BT]	12 VDC	negative (open)	spring return to 0	4,30
HK DG4V5 0CJ VM U 24DC		4/3	0CJ [PB/AT]-[ABPT]-[PA/BT]	24 VDC	negative (open)	spring return to 0	4,30
HK DG4V5 0C VM U 110AC		4/3	0C [PB/AT]-[ABPT]-[PA/BT]	110 VAC	negative (open)	spring return to 0	4,30
HK DG4V5 0C VM U 230AC		4/3	0C [PB/AT]-[ABPT]-[PA/BT]	230 VAC 50 Hz	negative (open)	spring return to 0	4,30
HK DG4V5 2CJ VM U 12DC		4/3	2CJ [PB/AT]-[A/B/P/T]-[PA/BT]	12 VDC	positive (closed)	spring return to 0	4,30
HK DG4V5 2CJ VM U 24DC		4/3	2CJ [PB/AT]-[A/B/P/T]-[PA/BT]	24 VDC	positive (closed)	spring return to 0	4,30
HK DG4V5 2C VM U 110AC		4/3	2C [PB/AT]-[A/B/P/T]-[PA/BT]	110 VAC	positive (closed)	spring return to 0	4,30
HK DG4V5 2C VM U 230AC		4/3	2C [PB/AT]-[A/B/P/T]-[PA/BT]	230 VAC 50 Hz	positive (closed)	spring return to 0	4,30
HK DG4V5 6CJ VM U 12DC		4/3	6CJ [PB/AT]-[ABT/P]-[PA/BT]	12 VDC	positive (closed)	spring return to 0	4,30
HK DG4V5 6CJ VM U 24DC		4/3	6CJ [PB/AT]-[ABT/P]-[PA/BT]	24 VDC	positive (closed)	spring return to 0	4,30
HK DG4V5 6C VM U 110AC		4/3	6C [PB/AT]-[ABT/P]-[PA/BT]	110 VAC	positive (closed)	spring return to 0	4,30
HK DG4V5 6C VM U 230AC		4/3	6C [PB/AT]-[ABT/P]-[PA/BT]	230 VAC 50 Hz	positive (closed)	spring return to 0	4,30
HK DG4V5 8CJ VM U 12DC		4/3	8CJ [PA/BT]-[A/B/PT]-[PB/AT]	12 VDC	negative (open)	spring return to 0	4,30
HK DG4V5 8CJ VM U 24DC		4/3	8CJ [PA/BT]-[A/B/PT]-[PB/AT]	24 VDC	negative (open)	spring return to 0	4,30
HK DG4V5 8CJ VM U 110AC		4/3	8CJ [PA/BT]-[A/B/PT]-[PB/AT]	110 VAC	negative (open)	spring return to 0	4,30
HK DG4V5 8CJ VM U 230AC		4/3	8CJ [PA/BT]-[A/B/PT]-[PB/AT]	230 VAC 50 Hz	negative (open)	spring return to 0	4,30
HK DG4V5 2NJ VM U 12DC		4/3	2NJ [PB/AT]-[PA/BT]	12 VDC	positive (closed)	2 latching positions	4,30
HK DG4V5 2NJ VM U 24DC		4/3	2NJ [PB/AT]-[PA/BT]	24 VDC	positive (closed)	2 latching positions	4,30
HK DG4V5 2N VM U 110AC		4/3	2N [PB/AT]-[PA/BT]	110 VAC	positive (closed)	2 latching positions	4,30
HK DG4V5 2N VM U 230AC		4/3	2N [PB/AT]-[PA/BT]	230 VAC 50 Hz	positive (closed)	2 latching positions	4,30

Piston type example: [A/B/PT] = [A blocked / B blocked / P+T connected]

(Continued)

HK DG4V5

Solenoid-operated directional control valve NG10

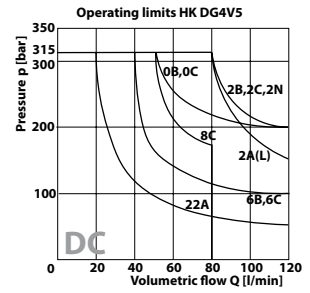
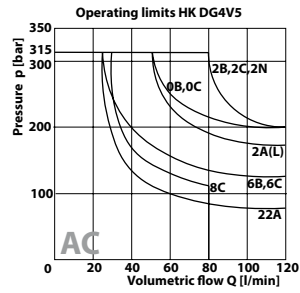
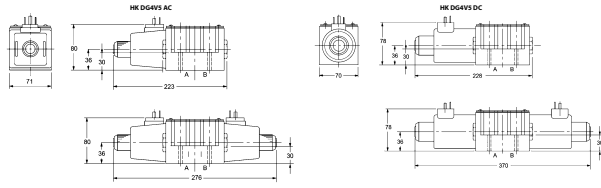

Web: <http://cat.hansa-flex.com/en/HKDG4V5>

Accessories:

- HK SP DG4V5 - Coil for HK DG4V5 solenoid-operated valve
- HK SP DIN 43650 - Electrical plug for solenoid coil DIN 43650 / ISO 4400
- HK M HK DK - Set of bolts for NG 10 valves types HK DK11/DKE/DG4V5



HK 42 C1 (7/G/Q/R)

Solenoid-operated directional control valve NG10

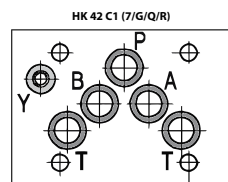

switching capacity limits see characteristic curves

- Design:** 4/2-way valve or 4/3-way valve, with manual emergency operation
- Scope of supply:** with coil, without plug
- Operating pressure:** P, A, B: max. 350bar / T: max. 100bar
- Volumetric flow:** max. 140 l/min (note characteristic curves)
- Connection:** ISO/Cetop 05 size 10
- Mounting:** 4 pcs. socket head screw M6x40 12.9

Ordering information: Further circuits and versions, volumetric flows and switching power limits on request

Identification	Circuit diagram	Type	Rated voltage/ current type	Overlap	Piston type	Design	Weight kg
HK 42 3151 0101 C1 R		4/2	12 VDC	positive (closed)	51 [PB/AT]-[PA/BT]	Spring return	3,4
HK 42 3151 0101 C1 Q		4/2	24 VDC	positive (closed)	51 [PB/AT]-[PA/BT]	Spring return	3,4
HK 42 3151 0101 C1 G		4/2	205 VDC	positive (closed)	51 [PB/AT]-[PA/BT]	Spring return	3,4
HK 42 3151 0101 C1 7		4/2	230 VAC 50 Hz	positive (closed)	51 [PB/AT]-[PA/BT]	Spring return	3,4
HK 42 3111 0101 C1 R		4/2	12 VDC	negative (open)	11 [PB/AT]-[PA/BT]	Spring return	3,4
HK 42 3111 0101 C1 Q		4/2	24 VDC	negative (open)	11 [PB/AT]-[PA/BT]	Spring return	3,4
HK 42 3111 0101 C1 G		4/2	205 VDC	negative (open)	11 [PB/AT]-[PA/BT]	Spring return	3,4
HK 42 3111 0101 C1 7		4/2	230 VAC 50 Hz	negative (open)	11 [PB/AT]-[PA/BT]	Spring return	3,4
HK 42 3151 0201 C1 R		4/2	12 VDC	positive (closed)	51 [PB/AT]-[PA/BT]	Spring return	3,4
HK 42 3151 0201 C1 Q		4/2	24 VDC	positive (closed)	51 [PB/AT]-[PA/BT]	Spring return	3,4
HK 42 3151 0201 C1 G		4/2	205 VDC	positive (closed)	51 [PB/AT]-[PA/BT]	Spring return	3,4
HK 42 3151 0201 C1 7		4/2	230 VAC 50 Hz	positive (closed)	51 [PB/AT]-[PA/BT]	Spring return	3,4
HK 42 3101 0601 C1 R		4/2	12 VDC	negative (open)	01 [PB/AT]-[ABPT]	Spring return	3,4
HK 42 3101 0601 C1 Q		4/2	24 VDC	negative (open)	01 [PB/AT]-[ABPT]	Spring return	3,4
HK 42 3101 0601 C1 G		4/2	205 VDC	negative (open)	01 [PB/AT]-[ABPT]	Spring return	3,4
HK 42 3101 0601 C1 7		4/2	230 VAC 50 Hz	negative (open)	01 [PB/AT]-[ABPT]	Spring return	3,4
HK 42 3103 0601 C1 R		4/2	12 VDC	positive (closed)	03 [PB/AT]-[A/B/P/T]	Spring return	3,4
HK 42 3103 0601 C1 Q		4/2	24 VDC	positive (closed)	03 [PB/AT]-[A/B/P/T]	Spring return	3,4
HK 42 3103 0601 C1 G		4/2	205 VDC	positive (closed)	03 [PB/AT]-[A/B/P/T]	Spring return	3,4
HK 42 3103 0601 C1 7		4/2	230 VAC 50 Hz	positive (closed)	03 [PB/AT]-[A/B/P/T]	Spring return	3,4
HK 42 3108 0601 C1 R		4/2	12 VDC	positive (closed)	08 [PB/AT]-[ABT/P]	Spring return	3,4

Piston type example: [A/B/PT] = [A blocked / B blocked / P+T connected]



(Continued) HK 42 C1 (7/G/Q/R)

Solenoid-operated directional control valve NG10

Identification	Circuit diagram	Type	Rated voltage/ current type	Overlap	Piston type	Design	Weight kg
HK 42 3108 0601 C1 Q		4/2	24 VDC	positive (closed)	08 [PB/AT]-[ABT/P]	Spring return	3,4
HK 42 3108 0601 C1 G		4/2	205 VDC	positive (closed)	08 [PB/AT]-[ABT/P]	Spring return	3,4
HK 42 3108 0601 C1 7		4/2	230 VAC 50 Hz	positive (closed)	08 [PB/AT]-[ABT/P]	Spring return	3,4
HK 42 3107 0601 C1 R		4/2	12 VDC	negative (open)	07 [PA/BT]-[A/B/PT]	Spring return	3,4
HK 42 3107 0601 C1 Q		4/2	24 VDC	negative (open)	07 [PA/BT]-[A/B/PT]	Spring return	3,4
HK 42 3107 0601 C1 G		4/2	205 VDC	negative (open)	07 [PA/BT]-[A/B/PT]	Spring return	3,4
HK 42 3107 0601 C1 7		4/2	230 VAC 50 Hz	negative (open)	07 [PA/BT]-[A/B/PT]	Spring return	3,4
HK 42 3172 0101 C1 R		4/2	12 VDC	positive (closed)	72 [PA/B/T]-[PB/A/T]	Spring return	3,4
HK 42 3172 0101 C1 Q		4/2	24 VDC	positive (closed)	72 [PA/B/T]-[PB/A/T]	Spring return	3,4
HK 42 3172 0101 C1 G		4/2	205 VDC	positive (closed)	72 [PA/B/T]-[PB/A/T]	Spring return	3,4
HK 42 3172 0101 C1 7		4/2	230 VAC 50 Hz	positive (closed)	72 [PA/B/T]-[PB/A/T]	Spring return	3,4
HK 42 3201 0302 C1 R		4/3	12 VDC	negative (open)	01 [PB/AT]-[ABPT]-[PA/BT]	spring return to 0	3,6
HK 42 3201 0302 C1 Q		4/3	24 VDC	negative (open)	01 [PB/AT]-[ABPT]-[PA/BT]	spring return to 0	3,6
HK 42 3201 0302 C1 G		4/3	205 VDC	negative (open)	01 [PB/AT]-[ABPT]-[PA/BT]	spring return to 0	3,6
HK 42 3201 0302 C1 7		4/3	230 VAC 50 Hz	negative (open)	01 [PB/AT]-[ABPT]-[PA/BT]	spring return to 0	3,6
HK 42 3203 0302 C1 R		4/3	12 VDC	positive (closed) 03	[PB/AT]-[A/B/P/T]-[PA/BT]	spring return to 0	3,6
HK 42 3203 0302 C1 Q		4/3	24 VDC	positive (closed) 03	[PB/AT]-[A/B/P/T]-[PA/BT]	spring return to 0	3,6
HK 42 3203 0302 C1 G		4/3	205 VDC	positive (closed) 03	[PB/AT]-[A/B/P/T]-[PA/BT]	spring return to 0	3,6
HK 42 3203 0302 C1 7		4/3	230 VAC 50 Hz	positive (closed) 03	[PB/AT]-[A/B/P/T]-[PA/BT]	spring return to 0	3,6
HK 42 3208 0302 C1 R		4/3	12 VDC	positive (closed)	08 [PB/AT]-[ABT/P]-[PA/BT]	spring return to 0	3,6
HK 42 3208 0302 C1 Q		4/3	24 VDC	positive (closed)	08 [PB/AT]-[ABT/P]-[PA/BT]	spring return to 0	3,6
HK 42 3208 0302 C1 G		4/3	205 VDC	positive (closed)	08 [PB/AT]-[ABT/P]-[PA/BT]	spring return to 0	3,6
HK 42 3208 0302 C1 7		4/3	230 VAC 50 Hz	positive (closed)	08 [PB/AT]-[ABT/P]-[PA/BT]	spring return to 0	3,6
HK 42 3207 0302 C1 R		4/3	12 VDC	negative (open)	07 [PA/BT]-[A/B/PT]-[PB/AT]	spring return to 0	3,6
HK 42 3207 0302 C1 Q		4/3	24 VDC	negative (open)	07 [PA/BT]-[A/B/PT]-[PB/AT]	spring return to 0	3,6
HK 42 3207 0302 C1 G		4/3	205 VDC	negative (open)	07 [PA/BT]-[A/B/PT]-[PB/AT]	spring return to 0	3,6

Piston type example: [A/B/PT] = [A blocked / B blocked / P+T connected] →

HK 42 C1 (7/G/Q/R)

(Continued)

Solenoid-operated directional control valve NG10

Identification	Circuit diagram	Type	Rated voltage/ current type	Overlap	Piston type	Design	Weight kg
HK 42 3207 0302 C1 7		4/3	230 VAC 50 Hz	negative (open)	07 [PA/BT]-[A/B/PT]-[PB/AT]	spring return to 0	3,6
HK 42 3751 0902 C1 R		4/2	12 VDC	positive (closed)	51 [PB/AT]-[PA/BT]	2 latching positions	3,6
HK 42 3751 0902 C1 Q		4/2	24 VDC	positive (closed)	51 [PB/AT]-[PA/BT]	2 latching positions	3,6
HK 42 3751 0902 C1 G		4/2	205 VDC	positive (closed)	51 [PB/AT]-[PA/BT]	2 latching positions	3,6
HK 42 3751 0902 C1 7		4/2	230 VAC 50 Hz	positive (closed)	51 [PB/AT]-[PA/BT]	2 latching positions	3,6

Piston type example: [A/B/PT] = [A blocked / B blocked / P+T connected]

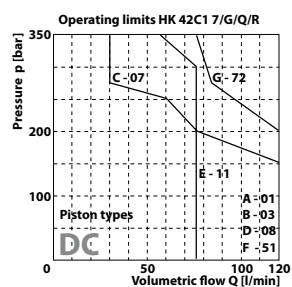
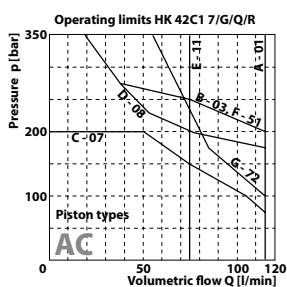
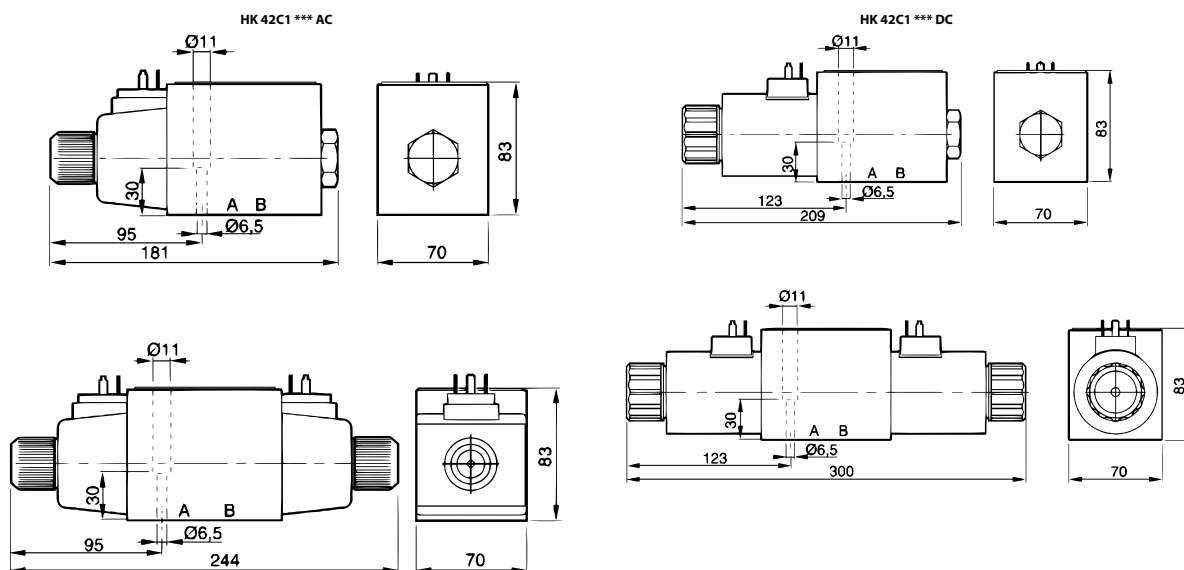

Piston types HK 42C1 7GQR

Piston type	P-A	P-B	A-T	B-T
01	D	D	A	A
03	D	D	C	C
07	D	D	D	D
08	D	D	B	B
11	D	D	B	B
51	D	D	C	C
72	C	D	-	-

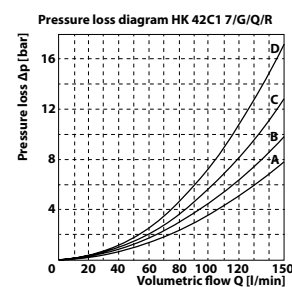

Web: <http://cat.hansa-flex.com/en/HK42C17GQR>

Accessories:

- HK SP 42C - Coil for solenoid-operated directional control valve HK42C
- HK SP DIN 43650 - Electrical plug for solenoid coil DIN 43650 / ISO 4400
- HK M HK 42 C - Set of bolts for NG10 valves type HK 42 C

HK DPH 2

Directional control valve NG16

These valves are actuated by a leak oil-reduced, solenoid-operated directional control valve size 6 set up as a pilot valve (type HK DHE *P*). Control is internal, but conversion to external is possible. The minimum control pressure for correct functioning is 8 bar.

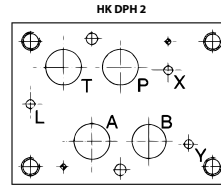

With the version with the control pressure generator, an additional pressure drop occurs, which ensures the minimum required control pressure for correct functioning. The version with the control pressure generator must be used if the pressure drop in the valve is below the minimum control pressure.

- Design:** 4/3-way valve (without pilot valve), pilot-controlled
- Operating pressure:** P, A, B: max. 350bar / T: max. 210bar
- Volumetric flow:** max. 300 l/min (note characteristic curves)
- Connection:** ISO/Cetop 07 NG16
- Mounting:** 2 No. hex. socket head screw M6x40 12.9 + 4 No. M10x50 12.9

Ordering information: Further circuits and versions, volumetric flows and switching power limits on request

Identification	Circuit diagram	Type	Overlap	Piston type	Design	Weight kg
HK DPH 2 710 DR SPIL		4/3	negative (open) 0	[PB/AT]-[ABPT]-[PA/BT]	Spring return, control pressure generator	7,5
HK DPH 2 711 D SPIL		4/3	positive (closed) 1	[PB/AT]-[A/B/P/T]-[PA/BT]	Spring return	7,5
HK DPH 2 713 D SPIL		4/3	positive (closed) 3	[PB/AT]-[ABT/P]-[PA/BT]	Spring return	8,0
HK DPH 2 714 DR SPIL		4/3	negative (open) 4	[PA/BT]-[A/B/PT]-[PB/AT]	Spring return, control pressure generator	7,5

Piston type example: [A/B/PT] = [A blocked / B blocked / P+T connected]

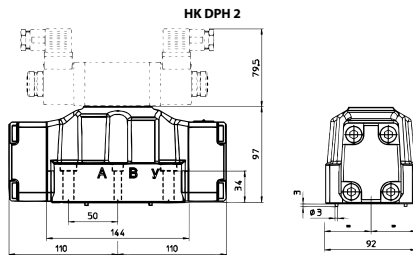

Piston types HK DPH 2

	P-A	P-B	A-T	B-T	P-T
Piston type 1, 3	A	A	D	A	-
0	A	A	D	E	C
4	C	C	H	I	F

Flow direction

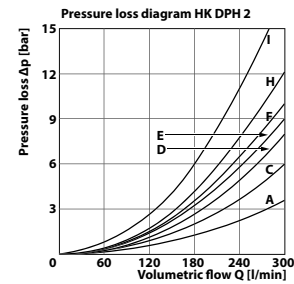

Web: <http://cat.hansa-flex.com/en/HKDPH2>

- Accessories:**
- HK DHE X 00 DC - Solenoid-operated directional control valve size 6 without coil
 - HK DHE X 00 AC - Solenoid-operated directional control valve size 6 without coil
 - HK M HK DPH 2 - Set of bolts for NG16 valves type HK DPH 2

HK DPH 4

Directional control valve NG25

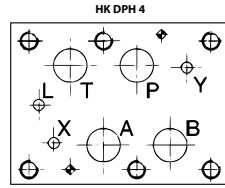

These valves are actuated by a leak oil-reduced, solenoid-operated directional control valve size 6 set up as a pilot valve (type HK DHE *P*). Control is internal, but conversion to external is possible. The minimum control pressure for correct functioning is 8 bar.

With the version with the control pressure generator, an additional pressure drop occurs, which ensures the minimum required control pressure for correct functioning. The version with the control pressure generator must be used if the pressure drop in the valve is below the minimum control pressure.

- Design:** 4/3-way valve (without pilot valve), pilot-controlled
- Operating pressure:** P, A, B: max. 350bar / T: max. 210bar
- Volumetric flow:** max. 650 l/min (note characteristic curves)
- Connection:** ISO/Cetop 08 NG25
- Mounting:** 6 No. hex. socket head screw M12x50 12.9

Ordering information: Further circuits and versions, volumetric flows and switching power limits on request

Identification	Circuit diagram	Type	Overlap	Piston type	Design	Weight kg
HK DPH 4 710 DR SPIL		4/3	negative (open) 0	[PB/AT]-[ABPT]-[PA/BT]	Spring return, control pressure generator	12,2
HK DPH 4 711 D SPIL		4/3	positive (closed) 1	[PB/AT]-[A/B/P/T]-[PA/BT]	Spring return	12,2
HK DPH 4 713 D SPIL		4/3	positive (closed) 3	[PB/AT]-[ABT/P]-[PA/BT]	Spring return	12,2
HK DPH 4 714 DR SPIL		4/3	negative (open) 4	[PA/BT]-[A/B/PT]-[PB/AT]	Spring return, control pressure generator	12,2

Piston type example: [A/B/PT] = [A blocked / B blocked / P+T connected]

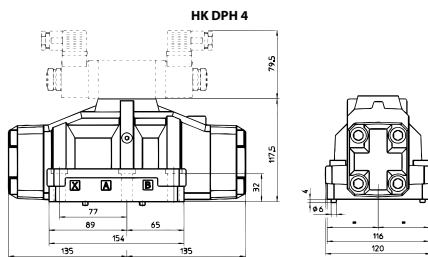

Piston types HK DPH 4

Piston type	Flow direction					
	P-A	P-B	A-T	B-T	P-T	
0	-	A	C	-	-	
1	-	D	D	-	-	
3	-	C	C	-	-	
4	-	E	F	-	-	

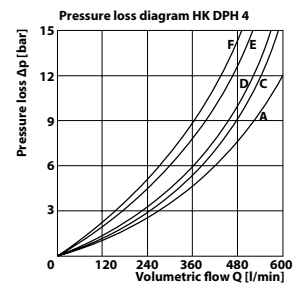

Web: <http://cat.hansa-flex.com/en/HKDPH4>

- Accessories:**
- HK DHE X 00 DC - Solenoid-operated directional control valve size 6 without coil
 - HK DHE X 00 AC - Solenoid-operated directional control valve size 6 without coil
 - HK M HK DPH 4 - Set of bolts for NG25 valves type HK DPH 4

HK DLO

Poppet valve NG6

2-way or 3-way seat valves with 2 switching positions
Solenoids and all moving parts switch internally in oil
Solenoid coil 24 VDC with emergency hand operation

- Scope of supply:** with coil, 24 DC, without plug
- Operating pressure:** P, A, B: max. 350bar / T: max. 160bar
- Volumetric flow:** max. 30 l/min (note characteristic curves)
- Connection:** ISO/Cetop 03 size 6
- Mounting:** 4 pcs. socket head screw M5x50 12.9

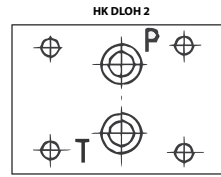

Note: The valves of type HK DLOH can be equipped with a plug-in non-return valve in port P (see accessories).

Identification	Circuit diagram	Type	Volumetric flow max. L/min	Design	Weight kg
HK DLOH 2AU X 24DC		2/2	12,0	power-off open	1,5
HK DLOH 2CU X 24DC		2/2	12,0	power-off closed	1,5
HK DLOH 3AU X 24DC		3/2	12,0	power-off open	1,5
HK DLOH 3CU X 24DC		3/2	12,0	power-off closed	1,5
HK DLOK 3AO X 24DC		3/2	30,0	power-off open	1,5
HK DLOK 3CO X 24DC		3/2	30,0	power-off closed	1,5

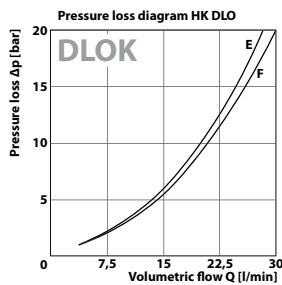
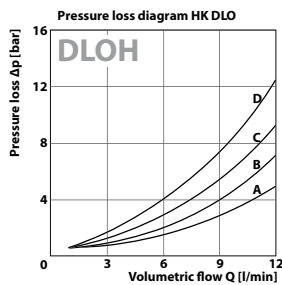
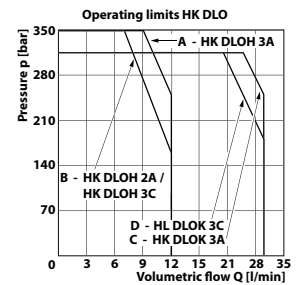
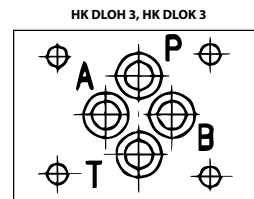
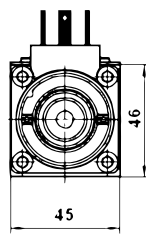
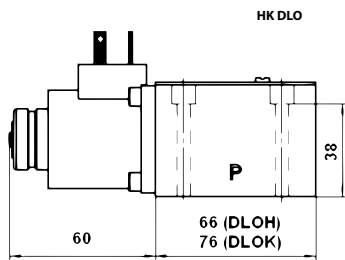

Piston types HK DLO

Piston type	P-A(T) A-T (P-B) B-T		Flow direction
DLOH-2A	B	-	
DLOH-2C	C	-	
DLOH-3A	D	C	
DLOH-3C	C	A	
DLOH-3A	F	E	
DLOH-3C	F	E	

Web: <http://cat.hansa-flex.com/en/HKDLO>

Accessories:

- HK SP 6 DLOH** - Plug-in non-return valve
- HK SP DIN 43650** - Electrical plug for solenoid coil DIN 43650 / ISO 4400
- HK M HK DH** - Screw set for NG 6 valves type HK DH / DG4V3

HK SP 6 DLOH

Plug-in non-return valve

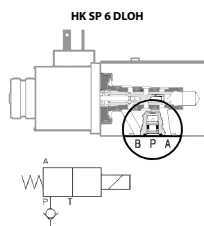

Design:

Plug-in non-return valve

Use:

For poppet valve HK DLOH, installation in connector P

Identification

HK SP 6 DLOH 100000 H

Weight

kg
0,15

Web: <http://cat.hansa-flex.com/en/HKSP6DLOH>

Accessory for following products:

HK DLO - Poppet valve NG6

1

HK DH04/05

Directional control valve NG6, hydraulically controlled

Hydraulic actuation with emergency hand operation
 Min. control pressure 3 bar / max. control pressure 70 bar / recommended control pressure 30 bar
 Thread on control pressure port 1/8" female thread

Design: 4/2-way valve or 4/3-way valve
Operating pressure: P, A, B: max. 350bar / T: max. 210bar
Volumetric flow: max. 50 l/min (note characteristic curves)
Connection: ISO/Cetop 03 size 6
Mounting: 4 pcs. socket head screw M5x50 12.9

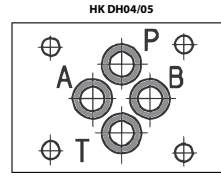

Ordering information: Further circuits and versions available on request

Identification	Circuit diagram	Type	Overlap	Piston type	Design	Weight kg
HK DH04 31 2		4/2	positive (closed)	1 [PB/AT]-[PA/BT]	Spring return	1,2
HK DH05 51 2		4/2	positive (closed)	1 [PB/AT]-[PA/BT]	2 external positions with detent	1,2
HK DH05 10		4/3	negative (open)	0 [PB/AT]-[ABPT]-[PA/BT]	spring return to 0	1,2
HK DH05 11		4/3	positive (closed)	1 [PB/AT]-[A/B/P/T]-[PA/BT]	spring return to 0	1,2
HK DH05 13		4/3	positive (closed)	3 [PB/AT]-[ABT/P]-[PA/BT]	spring return to 0	1,2

Piston type example: [A/B/PT] = [A blocked / B blocked / P+T connected]

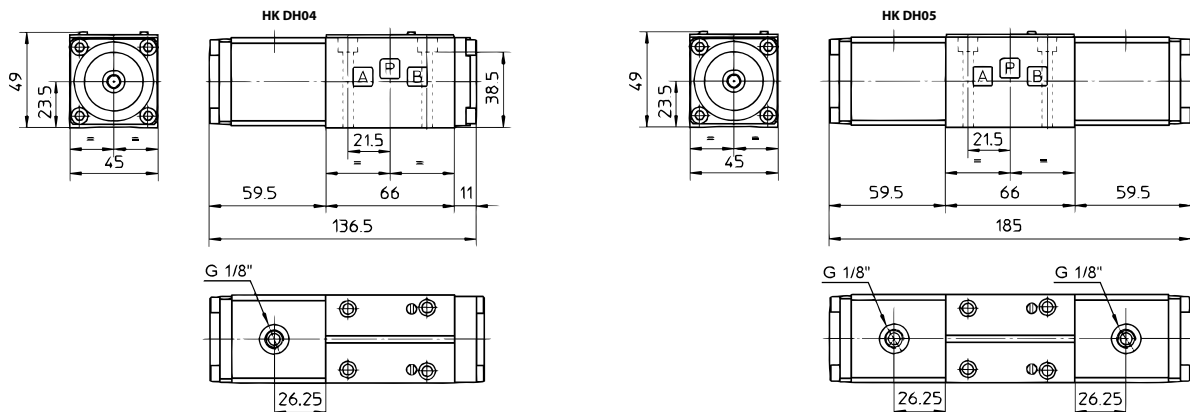

HK DH04/05

Piston type	Flow direction					
	P-A	P-B	A-T	B-T	P-T	
0	C	C	C	C		
1	A	A	A	A		
3	A	A	C	C		

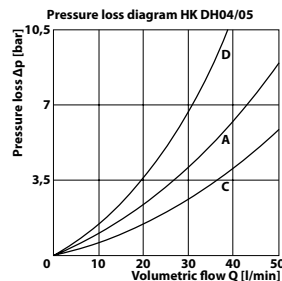

Web: <http://cat.hansa-flex.com/en/HKDH0405>

Accessories:
 HK M HK DH - Screw set for NG 6 valves type HK DH / DG4V3

HK DH08/09

Directional control valve NG6, pneumatically controlled

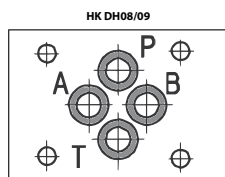

Pneumatic actuation with emergency hand operation
 Min. pneumatic control pressure 2 bar / recommended pneumatic control pressure 12 bar
 Thread on control pressure port 1/8" female thread

Design: 4/2-way valve or 4/3-way valve
Operating pressure: P, A, B: max. 350bar / T: max. 100bar
Volumetric flow: max. 50 l/min (note characteristic curves)
Connection: ISO/Cetop O3 size 6
Mounting: 4 pcs. socket head screw M5x50 12.9

Ordering information: Further circuits and versions available on request

Identification	Circuit diagram	Type	Overlap	Piston type	Design	Weight kg
HK DH08 10		4/2	negative (open)	0 [PB/AT]-[ABPT]	Spring return	1,2
HK DH08 31 2		4/2	positive (closed)	1 [PB/AT]-[PA/BT]	Spring return	1,2
HK DH09 10		4/3	negative (open)	0 [PB/AT]-[ABPT]-[PA/BT]	spring return to 0	1,2
HK DH09 11		4/3	positive (closed)	1 [PB/AT]-[A/B/P/T]-[PA/BT]	spring return to 0	1,2
HK DH09 13		4/3	positive (closed)	3 [PB/AT]-[ABT/P]-[PA/BT]	spring return to 0	1,2
HK DH09 14		4/3	negative (open)	4 [PA/BT]-[A/B/PT]-[PB/AT]	spring return to 0	1,2

Piston type example: [A/B/PT] = [A blocked / B blocked / P+T connected]

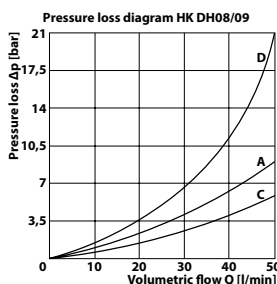
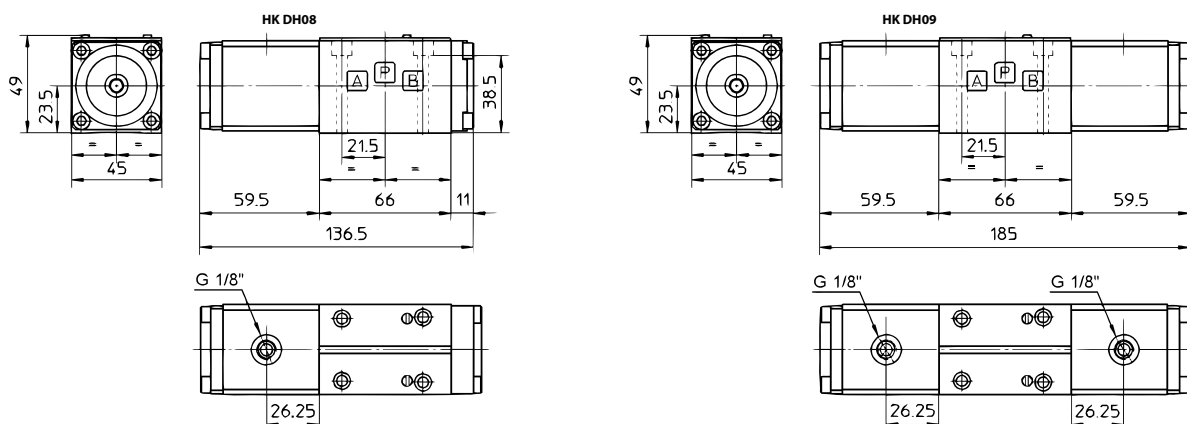

HK DH08/09

Piston type	Flow direction					
	P-A	P-B	A-T	B-T	P-T	T
0	C	C	C	C		
1	A	A	A	A		
3	A	A	C	C		
4	D	D	D	D	A	

Web: <http://cat.hansa-flex.com/en/HKDH0809>

Accessories:
 HK M HK DH - Screw set for NG 6 valves type HK DH / DG4V3

Solenoid-operated directional control valve size 6, Ex-protected

Electrically operated with ex-proof solenoids Type OA / 24 VDC
 Solenoids type-tested in accordance with ATEX 94/9/CE Ex II 2G EEx d II C T6/ T4/T3
 Power consumption of the solenoids 8 W
 Connecting thread of the solenoids GK: G1/2" ISO/UNI-6125 (conical)
 Connecting thread of the solenoids M: M20x1,5 UNI-4535
 Access to the internal terminal strip of the solenoids by removing the upper coil half
 Max. volumetric flow 70 l/min at p = 100 bar
 Max. volumetric flow 40 l/min at p = 210 bar
 Max. volumetric flow 20 l/min at p = 320 bar
Design: 4/2-way valve or 4/3-way valve
Operating pressure: P, A, B: max. 350bar / T: max. 120bar
Volumetric flow: max. 70 l/min (note characteristic curves)
Connection: ISO/Cetop 03 size 6
Mounting: 4 pcs. socket head screw M5x50 12.9

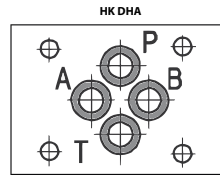

Ordering information: Further circuits and versions available on request

Identification	Circuit diagram	Type	Overlap	Piston type	Design	Weight kg
HK DHA 0631 2 PA GK 24		4/2	positive (closed)	1 [PB/AT]-[PA/BT]	Spring return	1,5
HK DHA 0631 2 M 7 24		4/2	positive (closed)	1 [PB/AT]-[PA/BT]	Spring return	1,5
HK DHA 0710 PA GK 24		4/3	negative (open)	0 [PB/AT]-[ABPT]-[PA/BT]	spring return to 0	1,8
HK DHA 0711 PA GK 24		4/3	positive (closed)	1 [PB/AT]-[A/B/P/T]-[PA/BT]	spring return to 0	1,8
HK DHA 0713 PA GK 24		4/3	positive (closed)	3 [PB/AT]-[ABT/P]-[PA/BT]	spring return to 0	1,8
HK DHA 0713 M 7 24		4/3	positive (closed)	3 [PB/AT]-[ABT/P]-[PA/BT]	spring return to 0	1,8
HK DHA 0714 PA GK 24		4/3	negative (open)	4 [PA/BT]-[A/B/PT]-[PB/AT]	spring return to 0	1,8

Desing PA: with cable gland PG9 (IP67) Piston type example: [A/B/PT] = [A blocked / B blocked / P+T connected]

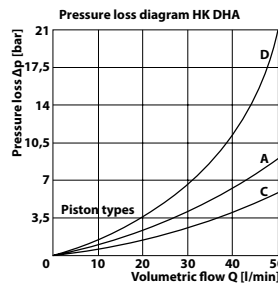
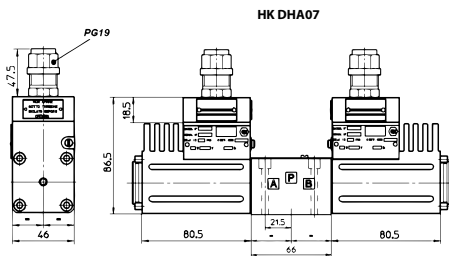
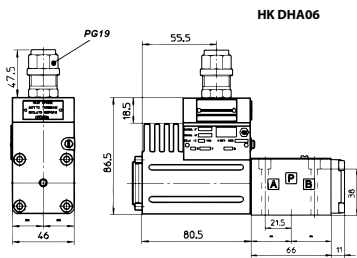

Piston type	P-A	P-B	A-T	B-T	P-T
0	C	C	C	C	
1	A	A	A	A	
3	A	A	C	C	
4	D	D	D	D	A

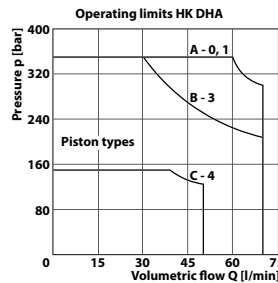

Web: <http://cat.hansa-flex.com/en/HKDHA>

Accessories:
 HK M HK DH - Screw set for NG 6 valves type HK DH / DG4V3

HK HM 01

Pressure relief valve

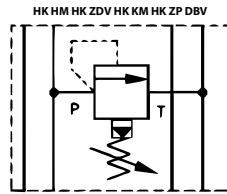

Sandwich body valve for constructing sandwich arrangements with ISO/Cetop 03 size 6 valves

- Design:** Sandwich body valve, pilot-controlled
- Operating pressure:** max. 350 bar
- Volumetric flow:** max. 50 l/min
- Connection:** ISO/Cetop 03 size 6

Note: These valves must be set according to the application.

Ordering information: Further sandwich body valves available on request

Identification	acts in channel	Pressure setting range		Plate height mm	Weight kg
		min. bar	max. bar		
HK HM 011 100	P	5	100	40	1,4
HK HM 011 210	P	5	210	40	1,4
HK HM 011 350	P	5	350	40	1,4
HK HM 012 100	A + B	5	100	40	1,4
HK HM 012 210	A + B	5	210	40	1,4
HK HM 012 350	A + B	5	350	40	1,4
HK HM 013 100	A	5	100	40	1,4
HK HM 013 210	A	5	210	40	1,4
HK HM 013 350	A	5	350	40	1,4
HK HM 014 100	B	5	100	40	1,4
HK HM 014 210	B	5	210	40	1,4
HK HM 014 350	B	5	350	40	1,4

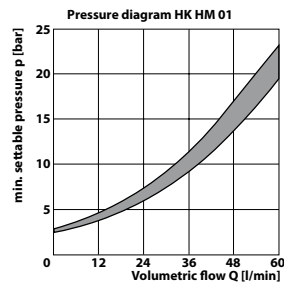
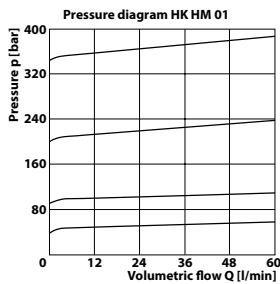
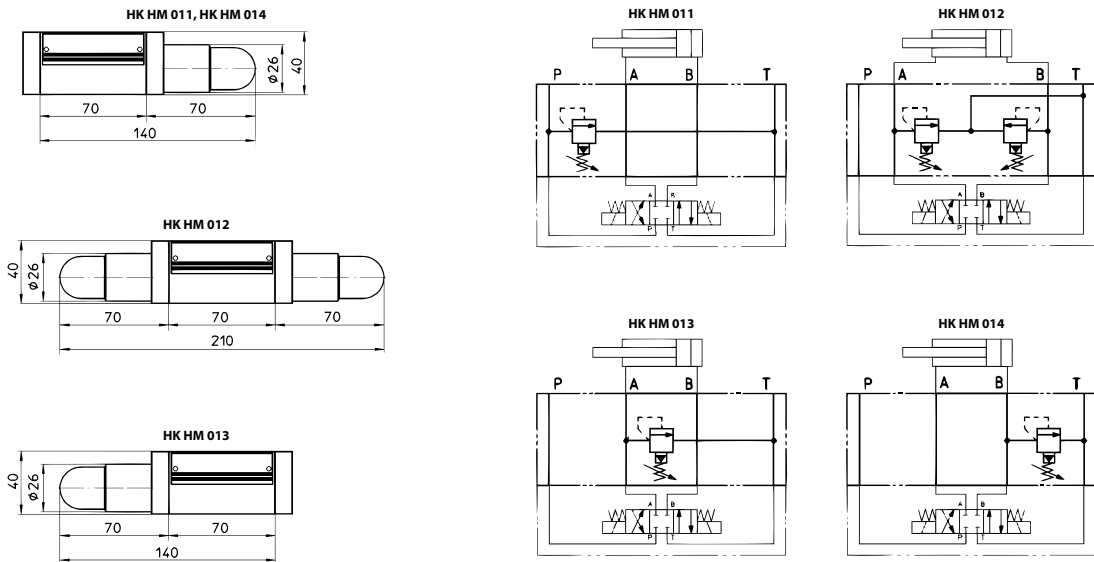

Web: <http://cat.hansa-flex.com/en/HKHM01>

HK HMP 01

Pressure relief valve

Sandwich body valve for constructing sandwich arrangements with ISO/Cetop 03 size 6 valves

- Design:** Sandwich body valve, direct-controlled
- Operating pressure:** max. 350 bar
- Volumetric flow:** max. 35 l/min
- Connection:** ISO/Cetop 03 size 6

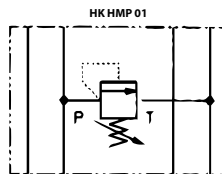

Note: These valves must be set according to the application.

Ordering information: Further sandwich body valves available on request

Identification	acts in channel	Pressure setting range		Plate height mm	Weight kg
		min. bar	max. bar		
HK HMP 011 100	P	3	100	40	1,4
HK HMP 011 210	P	10	210	40	1,4
HK HMP 011 350	P	3	350	40	1,4
HK HMP 012 100	A + B	3	100	40	1,4
HK HMP 012 210	A + B	10	210	40	1,4
HK HMP 012 350	A + B	15	350	40	1,4
HK HMP 013 100	A	3	100	40	1,4
HK HMP 013 210	A	10	210	40	1,4
HK HMP 013 350	A	15	350	40	1,4
HK HMP 014 350	B	15	350	40	1,4

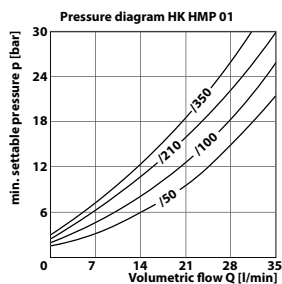
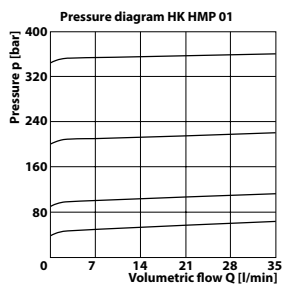
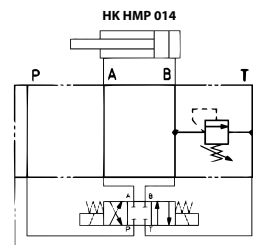
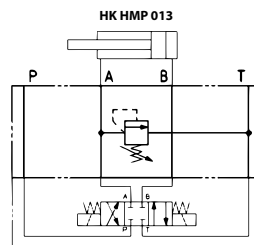
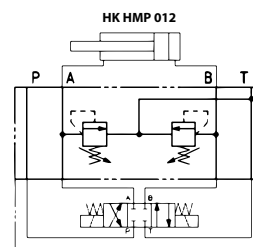
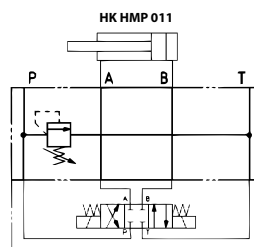
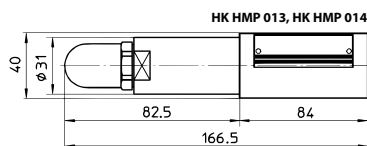
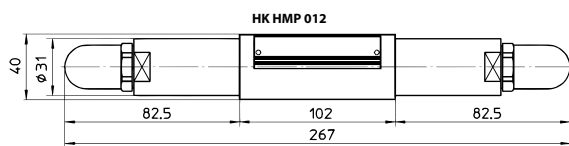
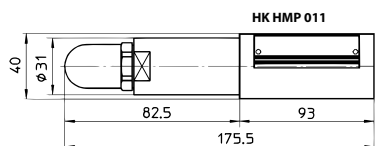

Web: <http://cat.hansa-flex.com/en/HKHMP01>

HK ZDV 01

Pressure relief valve

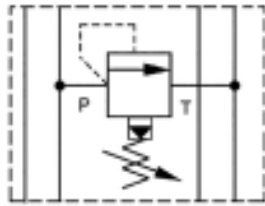

Sandwich body valve for constructing sandwich arrangements with ISO/Cetop 03 size 6 valves

Design: Sandwich body valve, pilot-controlled
Operating pressure: max. 350 bar
Volumetric flow: max. 80 l/min
Connection: ISO/Cetop 03 size 6

Note: These valves must be set according to the application.

Ordering information: Further sandwich body valves available on request

Identification	acts in channel	Pressure setting range		Plate height mm	Weight kg
		min. bar	max. bar		
HK ZDV P01 1 S0 D1	P	7	70	40	1,4
HK ZDV P01 5 S0 D1	P	7	350	40	1,4
HK ZDV AB01 1 S0 D1	A + B	7	70	49	1,4
HK ZDV AB01 5 S0 D1	A + B	7	315	49	1,4
HK ZDV A01 1 S0 D1	A	7	70	40	1,4
HK ZDV A01 5 S0 D1	A	7	350	40	1,4
HK ZDV B01 1 S0 D1	B	7	70	40	1,4
HK ZDV B01 5 S0 D1	B	7	350	40	1,4

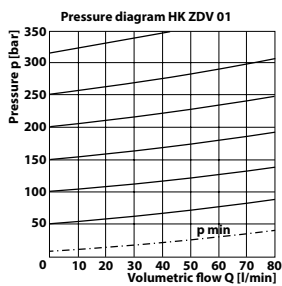
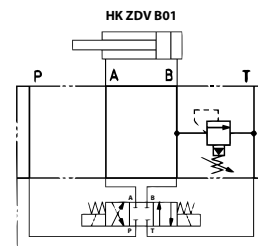
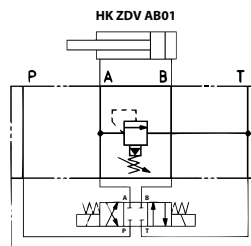
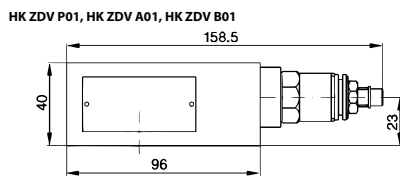
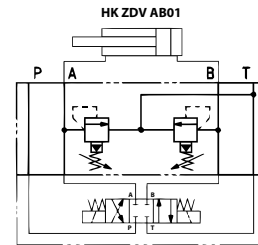
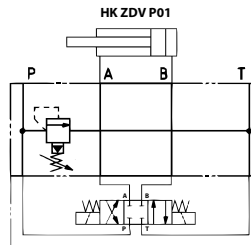
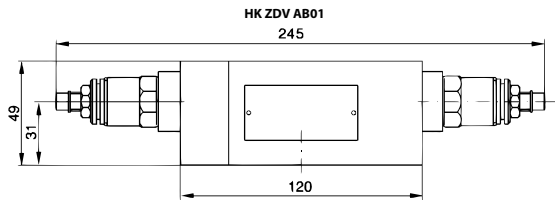

Web: <http://cat.hansa-flex.com/en/HKZDV01>

Pressure reduction valve

Sandwich body valve for constructing sandwich arrangements with ISO/Cetop 03 size 6 valves

Design: Sandwich body valve, direct-controlled
Operating pressure: max. 350 bar
Volumetric flow: max. 40 l/min
Connection: ISO/Cetop 03 size 6

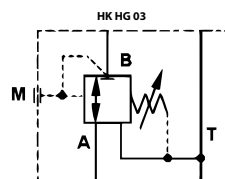

Note: These valves must be set according to the application.

Ordering information: Further sandwich body valves available on request

Identification	acts in channel	Pressure setting range		Plate height mm	Weight kg
		min. bar	max. bar		
HK HG 031 032	P	3	32	40	1,4
HK HG 031 100	P	20	100	40	1,4
HK HG 031 210	P	50	210	40	1,4
HK HG 033 032	A	3	32	40	1,4
HK HG 033 100	A	20	100	40	1,4
HK HG 033 210	A	50	210	40	1,4
HK HG 034 032	B	3	32	40	1,4
HK HG 034 100	B	20	100	40	1,4
HK HG 034 210	B	50	210	40	1,4

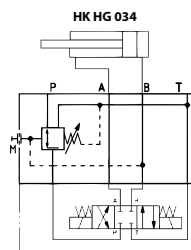
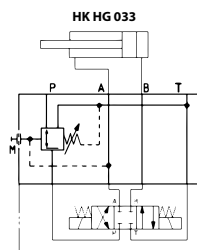
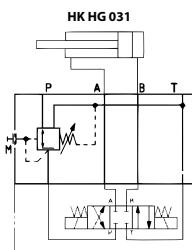
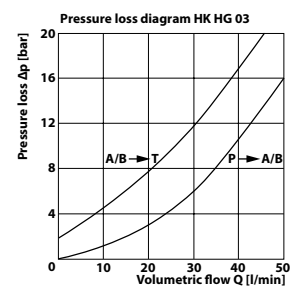
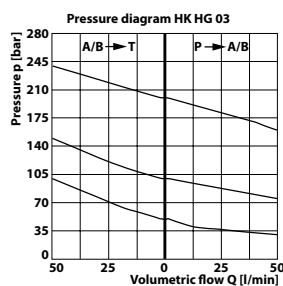
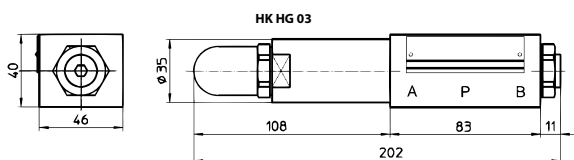

Web: <http://cat.hansa-flex.com/en/HKHG03>

HK ZDR 01

Pressure reduction valve

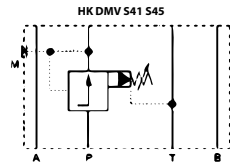

Sandwich body valve for constructing sandwich arrangements with ISO/Cetop 03 size 6 valves

- Design:** Sandwich body valve
- Operating pressure:** max. 350 bar
- Volumetric flow:** max. 80 l/min
- Connection:** ISO/Cetop 03 size 6

Note: These valves must be set according to the application.

Ordering information: Further sandwich body valves available on request

Identification	acts in channel	Pressure setting range		Design	Plate height mm	Weight kg
		min. bar	max. bar			
HK ZDR P01 1 S0 D1	P	7	70	pilot-controlled	40	1,4
HK ZDR P01 5 S0 D1	P	7	350	pilot-controlled	40	1,4
HK ZDR AR01 1 S0 D1	A	7	70	pilot-controlled, with non-return valve	40	1,4
HK ZDR AR01 5 S0 D1	A	7	315	pilot-controlled, with non-return valve	40	1,4
HK ZDR BR01 1 S0 D1	B	7	70	pilot-controlled, with non-return valve	40	1,4
HK ZDR BR01 5 S0 D1	B	7	315	pilot-controlled, with non-return valve	40	1,4

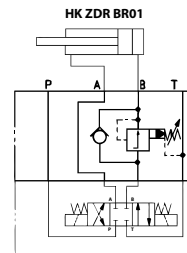
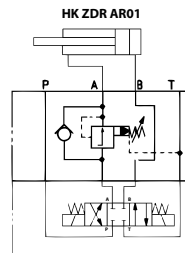
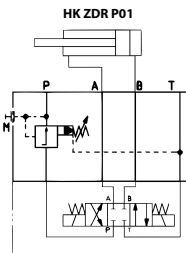
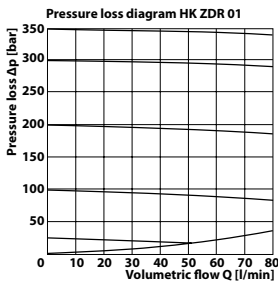
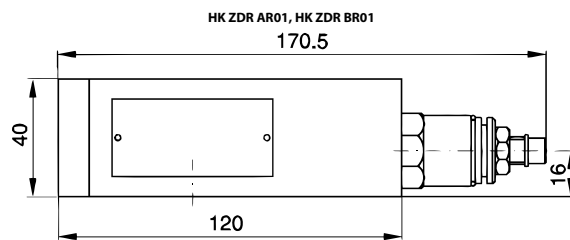
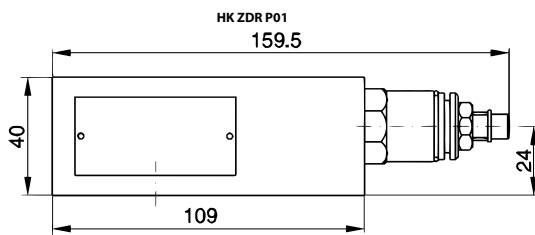

Web: <http://cat.hansa-flex.com/en/HKZDR01>

Flow control check valve

Sandwich body valve for constructing sandwich arrangements with ISO/Cetop 03 size 6 valves

Design: Sandwich body valve
Operating pressure: max. 350 bar
Connection: ISO/Cetop 03 size 6

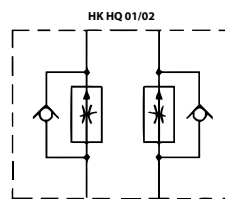

Note: These valves must be set according to the application.

Ordering information: Further sandwich body valves available on request

Identification	acts in channel	Volumetric flow max. L/min	Design	Plate height mm	Weight kg
HK HQ 012	A + B	50,0	Drain control	40	1,4
HK HQ 012 U	A + B	25,0	Drain control fine	40	1,2
HK HQ 013	A	50,0	Drain control	40	1,4
HK HQ 014	B	50,0	Drain control	40	1,4
HK HQ 022	A + B	50,0	Inlet control	40	1,4
HK HQ 022 U	A + B	25,0	Drain control fine	40	1,2
HK HQ 023	A	50,0	Inlet control	40	1,4
HK HQ 024	B	50,0	Inlet control	40	1,4

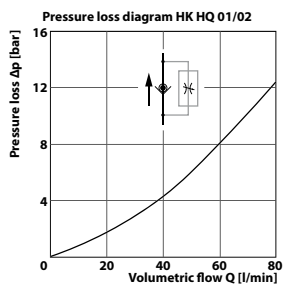
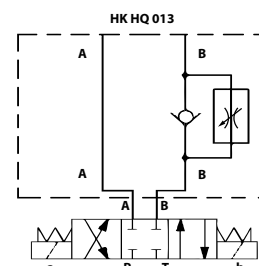
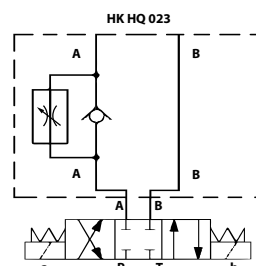
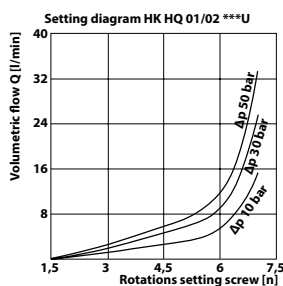
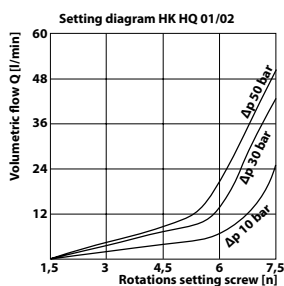
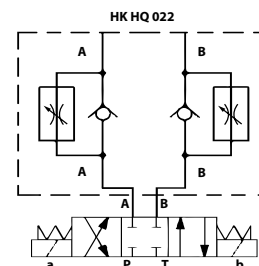
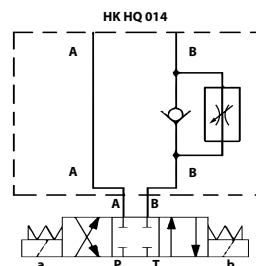
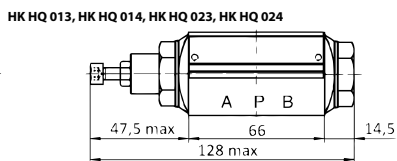
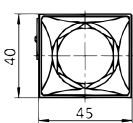
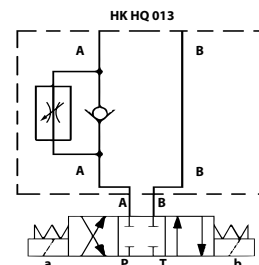
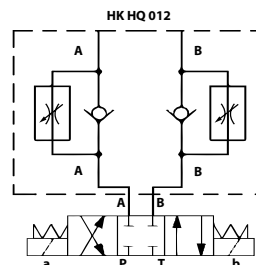
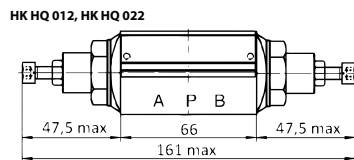
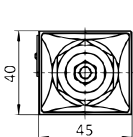

Web: <http://cat.hansa-flex.com/en/HKHQ0102>

HK ZRD 01

Flow control check valve

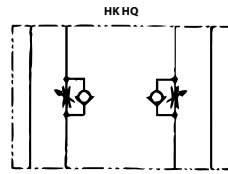

Sandwich body valve for constructing sandwich arrangements with ISO/Cetop 03 size 6 valves

- Design:** Sandwich body valve
- Operating pressure:** max. 350 bar
- Volumetric flow:** max. 80 l/min
- Connection:** ISO/Cetop 03 size 6

Note: These valves must be set according to the application.

Ordering information: Further sandwich body valves available on request

Identification	acts in channel	Design	Plate height mm	Weight kg
HK ZRD ABA01 S0 D1	A + B	Drain control	40	1,4
HK ZRD AA01 S0 D1	A	Drain control	40	1,4
HK ZRD BA01 S0 D1	B	Drain control	40	1,4
HK ZRD ABZ01 S0 D1	A + B	Inlet control	40	1,4
HK ZRD BZ01 S0 D1	B	Inlet control	40	1,4
HK ZRD AZ01 S0 D1	A	Inlet control	40	1,4

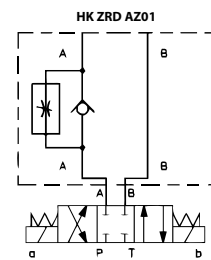
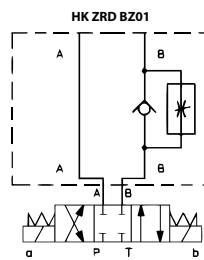
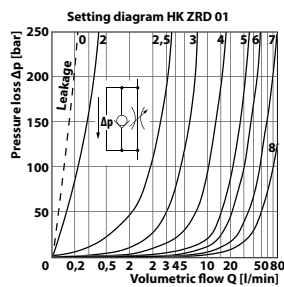
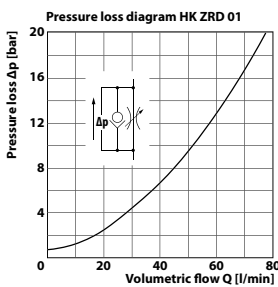
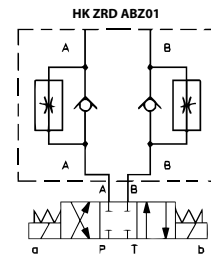
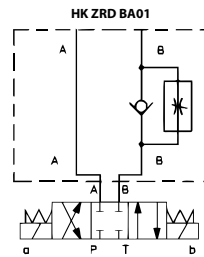
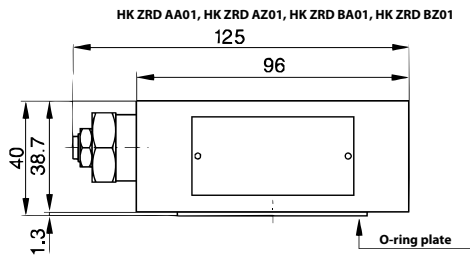
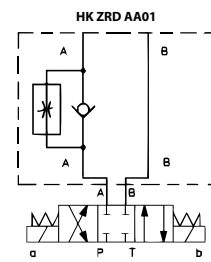
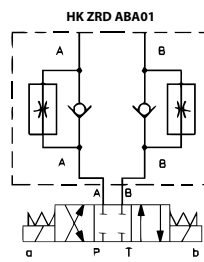
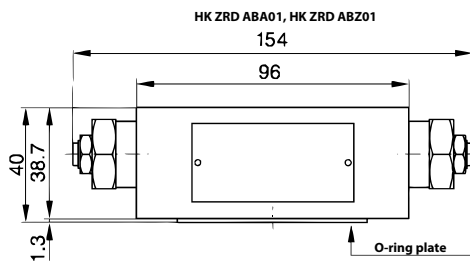

Web: <http://cat.hansa-flex.com/en/HKZRD01>

HK HR 01

Check valve

Sandwich body valve for constructing sandwich arrangements with ISO/Cetop 03 size 6 valves

- Design:** Sandwich body valve
- Operating pressure:** max. 350 bar
- Volumetric flow:** max. 60 l/min
- Connection:** ISO/Cetop 03 size 6

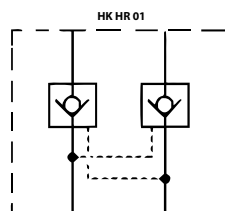

Ordering information: Further sandwich body valves available on request

Identification	acts in channel	Design	Plate height mm	Weight kg
HK HR 011	P	direct-controlled	40	1,40
HK HR 012	A + B	pilot controlled, opening ratio 1:3.3	40	1,05
HK HR 013	A	pilot controlled, opening ratio 1:3.3	40	1,40
HK HR 014	B	pilot controlled, opening ratio 1:3.3	40	1,40
HK HR 016	T	direct-controlled	40	1,40

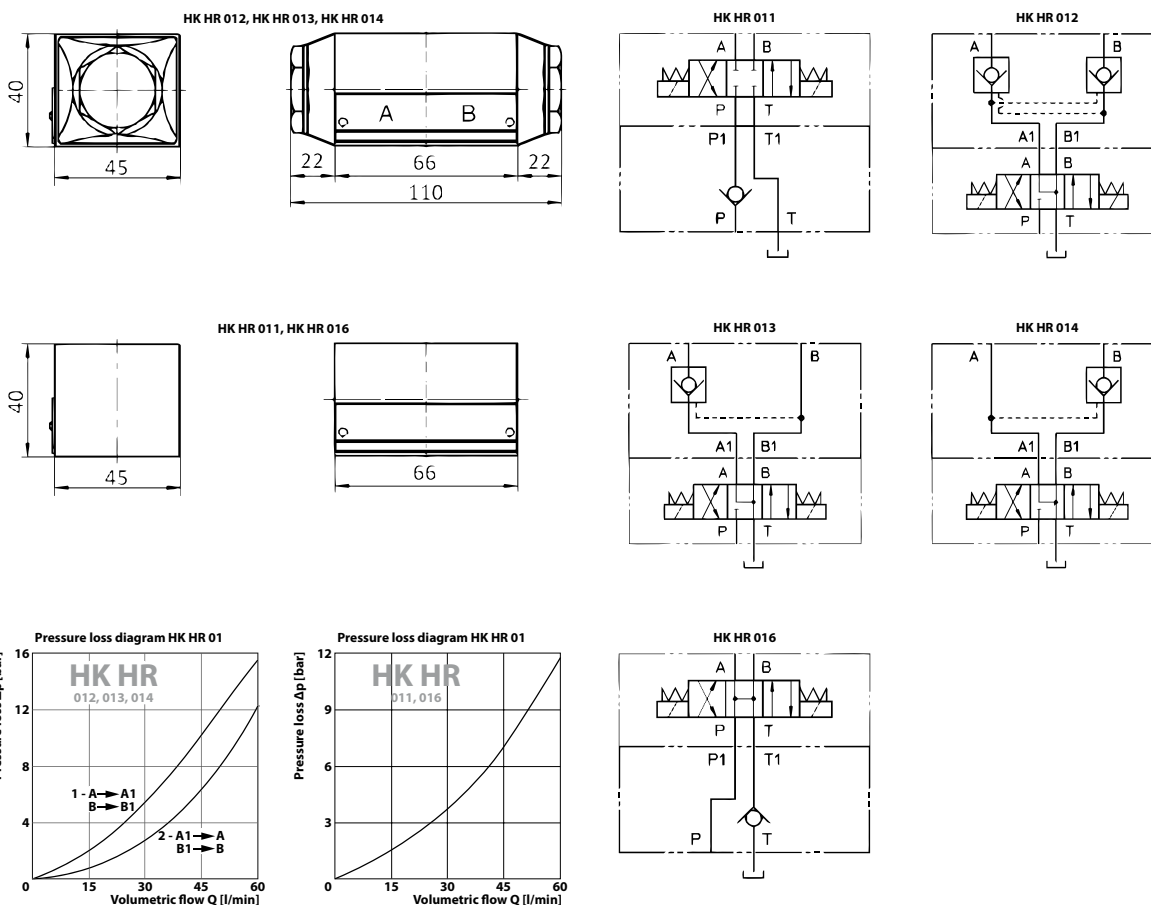

Web: <http://cat.hansa-flex.com/en/HKHR01>

HK ZRV 01 / ZRE 01

Check valve

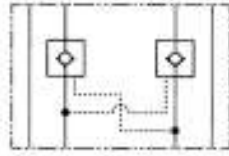

Sandwich body valve for constructing sandwich arrangements with ISO/Cetop 03 size 6 valves

Design: Sandwich body valve
Operating pressure: max. 350 bar
Connection: ISO/Cetop 03 size 6

Note: These valves must be set according to the application.

Ordering information: Further sandwich body valves available on request

Identification	acts in channel	Volumetric flow max. L/min	Design	Plate height mm	Weight kg
HK ZRV P01	P	40,0	direct-controlled	31	1,4
HK ZRE AB01 D1	A + B	60,0	pilot controlled, opening ratio 1: 6	40	1,4
HK ZRE A01 D1	A	60,0	pilot controlled, opening ratio 1: 6	40	1,4
HK ZRE B01 D1	B	60,0	pilot controlled, opening ratio 1: 6	40	1,4

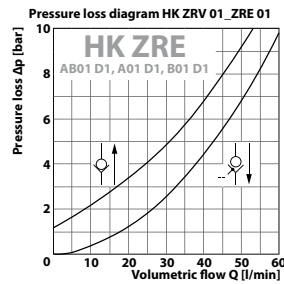
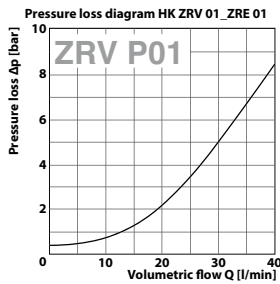
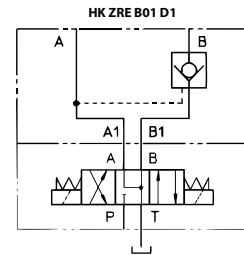
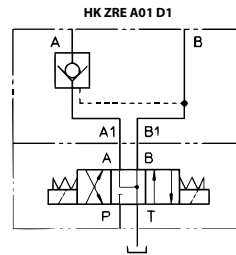
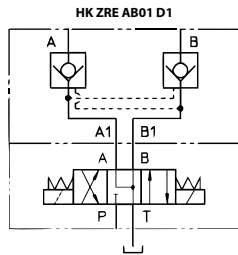
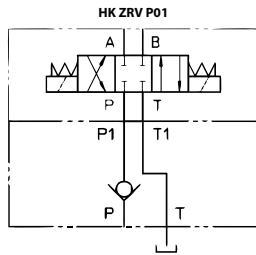
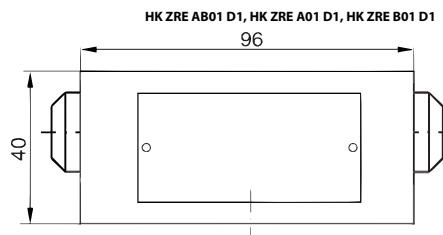
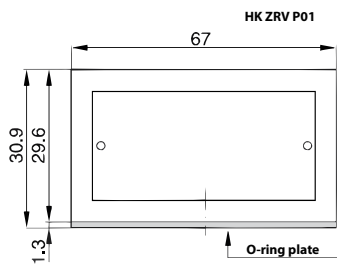

Web: <http://cat.hansa-flex.com/en/HKZRV01ZRE01>

HK ZNS 01

Overcentre valve

Sandwich body valve for constructing sandwich arrangements with ISO/Cetop 03 size 6 valves

Design: Sandwich body valve
Operating pressure: max. 350 bar
Volumetric flow: max. 60 l/min
Connection: ISO/Cetop 03 size 6

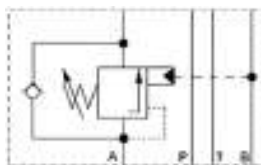

Note: These valves must be set according to the application.

Ordering information: Further sandwich body valves available on request

Identification	acts in channel	Pressure setting range		Design	Plate height mm	Weight kg
		min. bar	max. bar			
HK ZNS A01 2 S0 D1	A	70	175	Opening ratio 1 : 4.5	40	1,4
HK ZNS A01 5 S0 D1	A	140	350	Opening ratio 1 : 4.5	40	1,4
HK ZNS B01 2 S0 D1	B	70	175	Opening ratio 1 : 4.5	40	1,4
HK ZNS B01 5 S0 D1	B	140	350	Opening ratio 1 : 4.5	40	1,4
HK ZNS AB01 2 S0 D1	A + B	70	175	Opening ratio 1 : 4.5	40	1,4
HK ZNS AB01 5 S0 D1	A + B	140	350	Opening ratio 1 : 4.5	40	1,4

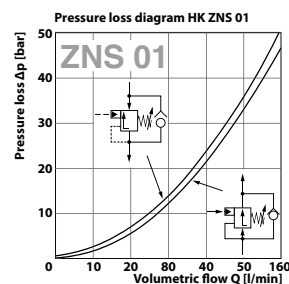
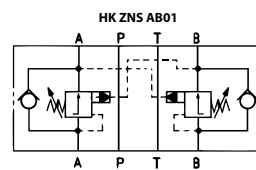
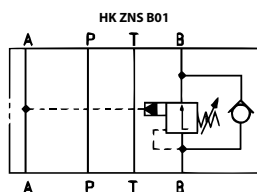
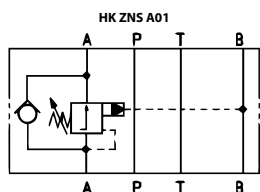
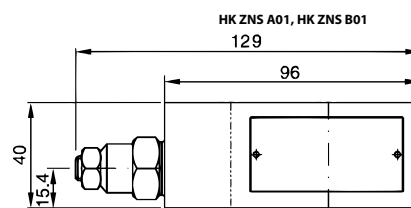
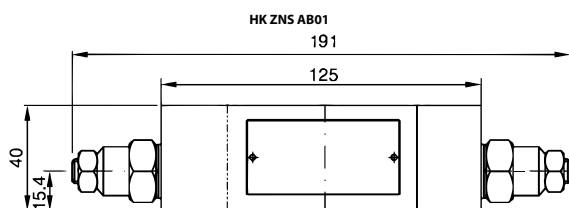

Web: <http://cat.hansa-flex.com/en/HKZNS01>

HK HC 01

2-way pressure balance

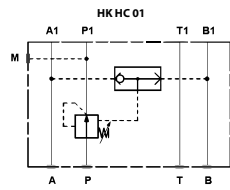

Sandwich body valve for constructing sandwich arrangements with ISO/Cetop 03 size 6 valves

The pressure balance maintains a constant pressure differential between connection P and connection A or B of the valve, to ensure that a constant flow rate is maintained in the event of pressure variations. The control pressure is diverted by the built-in shuttle valve.

Design: Sandwich body valve, pilot-controlled

Operating pressure: max. 350 bar

Volumetric flow: max. 50 l/min

Connection: ISO/Cetop 03 size 6

Note: These valves must be set according to the application.

Ordering information: Further sandwich body valves available on request

Identification	acts in channel	Pressure setting range min. bar	Pressure setting range max. bar	Plate height mm	Weight kg
HK HC 011 30	P	5	32	40	1,4

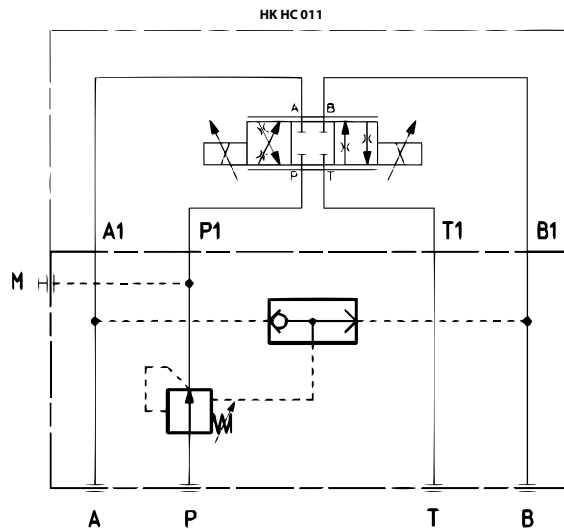
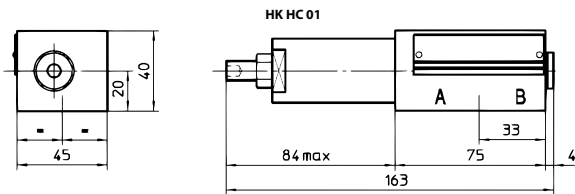

Web: <http://cat.hansa-flex.com/en/HKHC01>

HK HS 01

Pressure sequence valve

Sandwich body valve for constructing sandwich arrangements with ISO/Cetop 03 size 6 valves

- Design:** Sandwich body valve, direct-controlled
- Operating pressure:** max. 350 bar
- Volumetric flow:** max. 40 l/min
- Connection:** ISO/Cetop 03 size 6

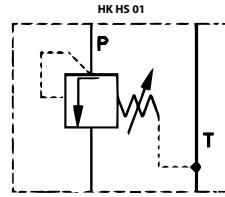

Note: These valves must be set according to the application.

Ordering information: Further sandwich body valves available on request

Identification	acts in channel	Pressure setting range		Plate height mm	Weight kg
		min. bar	max. bar		
HK HS 011 32	P	3	32	40	2,0
HK HS 011 100	P	20	100	40	2,0
HK HS 011 210	P	50	210	40	2,0

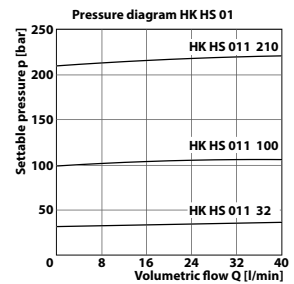
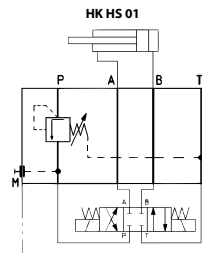
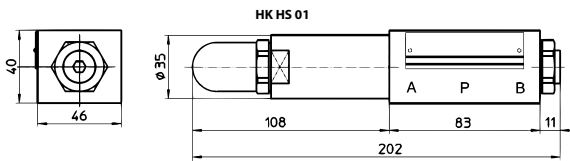

Web: <http://cat.hansa-flex.com/en/HKHS01>

Accessories:
HK EBM AS - Proportional amplifier digital

HK BA 210

Sandwich body with measurement connection

Sandwich body valve for constructing sandwich arrangements with ISO/Cetop 03 size 6 valves

- Design:** Sandwich body valve, 2x G3/8" measuring connections
- Scope of supply:** incl. O-rings (4x OR 8.73 x 1.78 / 70 Sh)
- Operating pressure:** max. 350 bar
- Connection:** ISO/Cetop 03 size 6

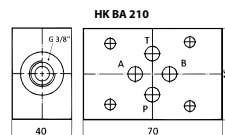

Ordering information: Further sandwich body valves available on request

Identification	acts in channel	Plate height	Weight kg
		mm	
HK BA 210 AB	A + B	40	0,5
HK BA 210 PT	P + T	40	0,5

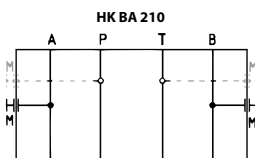

Web: <http://cat.hansa-flex.com/en/HKBA210>

HK GEH ZP NG6 KH

Valve housing ZP NG6 with ball valve

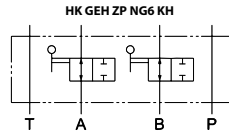
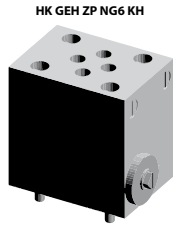

Sandwich body valve with shut-off ball valves for constructing sandwich arrangements with ISO/Cetop 03 NG6 valves
 This sandwich plate allows all the components above it to be shut off – with no pressure relief or emptying and without adversely affecting the rest of the circuit.

- Design:** Sandwich body valve, Ball valve in A+B
- Scope of supply:** incl. 1x hand lever for ball valve
- Operating pressure:** max. 315 bar
- Volumetric flow:** max. 80 l/min
- Connection:** ISO/Cetop 03 size 6

Ordering information: Other designs available on request

Identification	acts in channel	Plate height mm	Weight kg
HK ZP NG6 KH AB	A + B	68	1,5

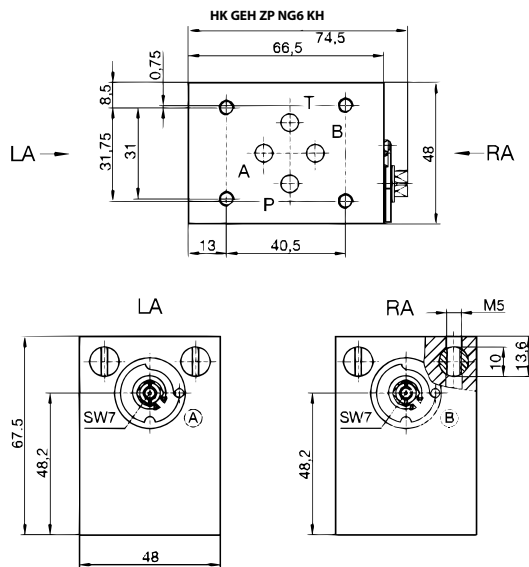

Web: <http://cat.hansa-flex.com/en/HKGEHZPNG6KH>

Pressure relief valve

Sandwich body valve for constructing sandwich arrangements with ISO/Cetop 05 size 10 valves

Design: Sandwich body valve, pilot-controlled
Operating pressure: max. 350 bar
Volumetric flow: max. 100 l/min
Connection: ISO/Cetop 05 size 10

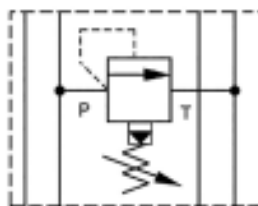

Note: These valves must be set according to the application.

Ordering information: Further sandwich body valves available on request

Identification	acts in channel	Pressure setting range		Plate height mm	Weight kg
		min. bar	max. bar		
HK KM 011 100	P	5	100	50	2,8
HK KM 011 210	P	5	210	50	2,8
HK KM 011 350	P	5	350	50	2,8
HK KM 012 100	A + B	5	100	50	2,8
HK KM 012 210	A + B	5	210	50	2,8
HK KM 012 350	A + B	5	350	50	2,8
HK KM 013 100	A	5	100	50	2,8
HK KM 013 210	A	5	210	50	2,8
HK KM 013 350	A	5	350	50	2,8
HK KM 014 100	B	5	100	50	2,8
HK KM 014 210	B	5	210	50	2,8
HK KM 014 350	B	5	350	50	2,8

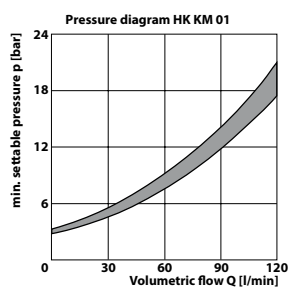
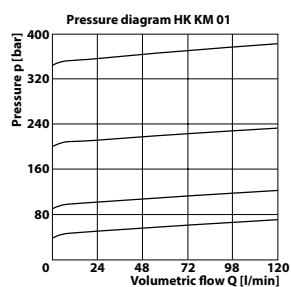
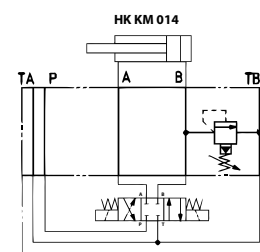
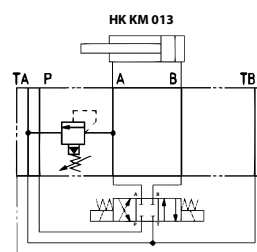
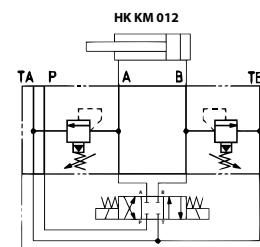
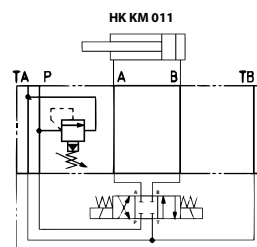
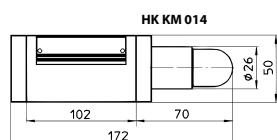
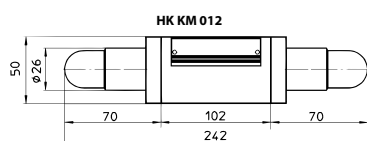
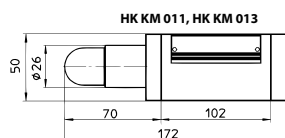

Web: <http://cat.hansa-flex.com/en/HK KM 01>

HK ZDV 02

Pressure relief valve

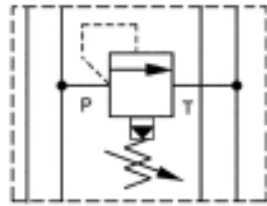

Sandwich body valve for constructing sandwich arrangements with ISO/Cetop 05 size 10 valves

- Design:** Sandwich body valve, pilot-controlled
- Operating pressure:** max. 350 bar
- Volumetric flow:** max. 140 l/min
- Connection:** ISO/Cetop 05 size 10

Note: These valves must be set according to the application.

Ordering information: Further sandwich body valves available on request

Identification	acts in channel	Pressure setting range		Plate height mm	Weight kg
		min. bar	max. bar		
HK ZDV P02 1 S0 D1	P	7	70	50	2,8
HK ZDV P02 5 S0 D1	P	7	350	50	2,8
HK ZDV AB02 1 S0 D1	A + B	7	70	50	2,8
HK ZDV AB02 5 S0 D1	A + B	7	315	50	2,8
HK ZDV A02 1 S0 D1	A	7	70	50	2,8
HK ZDV A02 5 S0 D1	A	5	350	50	2,8
HK ZDV B02 1 S0 D1	B	7	70	50	2,8
HK ZDV B02 5 S0 D1	B	5	350	50	2,8

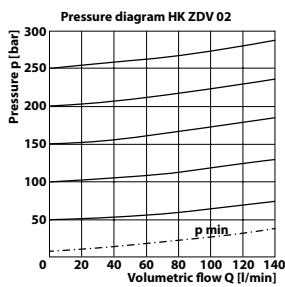
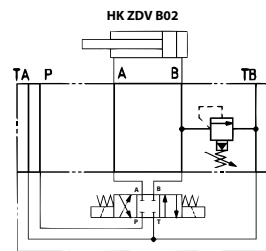
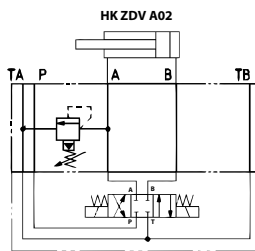
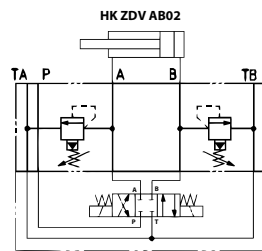
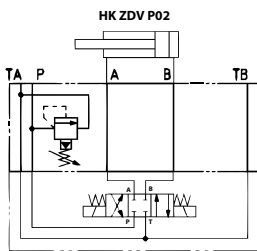
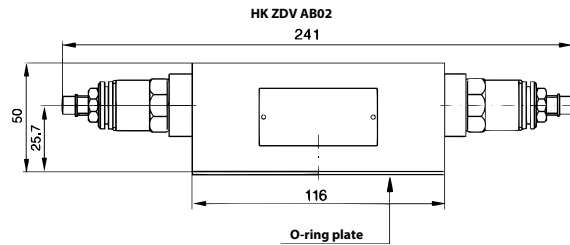
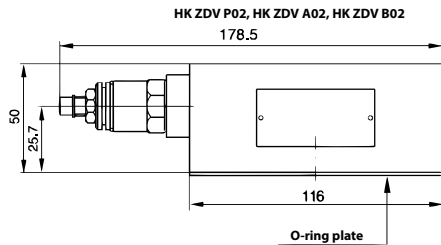

Web: <http://cat.hansa-flex.com/en/HKZDV02>

HK KG 03

Pressure reduction valve

Sandwich body valve for constructing sandwich arrangements with ISO/Cetop 05 size 10 valves

- Design:** Sandwich body valve, pilot-controlled
- Operating pressure:** max. 350 bar
- Volumetric flow:** max. 80 l/min
- Connection:** ISO/Cetop 05 size 10

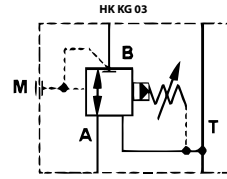

Note: These valves must be set according to the application.

Ordering information: Further sandwich body valves available on request

Identification	acts in channel	Pressure setting range min. bar	Pressure setting range max. bar	Plate height mm	Weight kg
HK KG 031 100	P	7	100	50	2,8
HK KG 031 210	P	7	210	50	2,8
HK KG 034 210	B	7	210	50	2,8

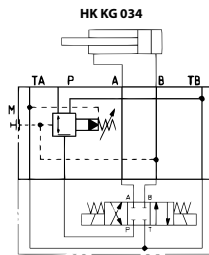
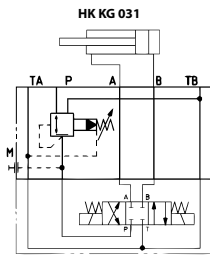
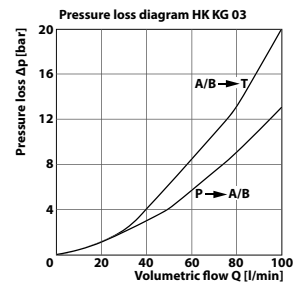
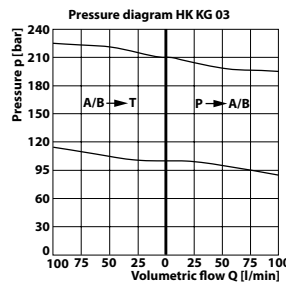
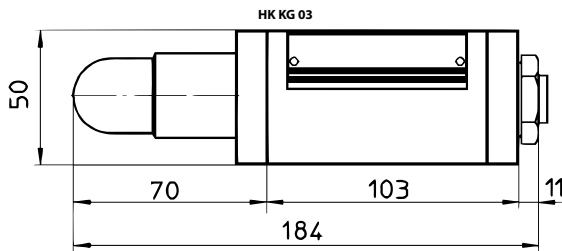

Web: <http://cat.hansa-flex.com/en/HKKG03>

HK ZDR 02

Pressure reduction valve

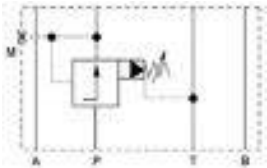

Sandwich body valve for constructing sandwich arrangements with ISO/Cetop 05 size 10 valves

- Design:** Sandwich body valve
- Operating pressure:** max. 350 bar
- Volumetric flow:** max. 120 l/min
- Connection:** ISO/Cetop 05 size 10

Note: These valves must be set according to the application.

Ordering information: Further sandwich body valves available on request

Identification	acts in channel	Pressure setting range		Design	Plate height mm	Weight kg
		min. bar	max. bar			
HK ZDR P02 1 S0 D1	P	7	70	pilot-controlled	50	2,8
HK ZDR P02 5 S0 D1	P	7	350	pilot-controlled	50	2,8
HK ZDR AR02 1 S0 D1	A	7	70	pilot-controlled, with non-return valve	50	2,8
HK ZDR AR02 5 S0 D1	A	7	315	pilot-controlled, with non-return valve	50	2,8
HK ZDR BR02 1 S0 D1	B	7	70	pilot-controlled, with non-return valve	50	2,8
HK ZDR BR02 5 S0 D1	B	7	315	pilot-controlled, with non-return valve	50	2,8

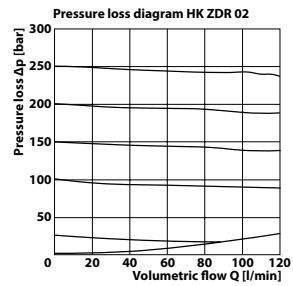
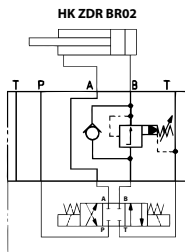
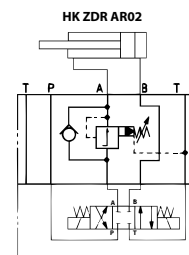
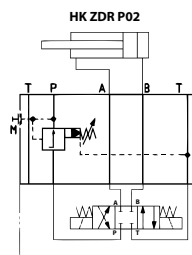
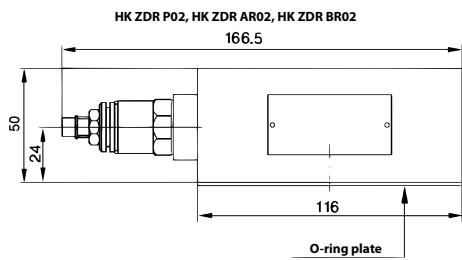

Web: <http://cat.hansa-flex.com/en/HKZDR02>

Flow control check valve

Sandwich body valve for constructing sandwich arrangements with ISO/Cetop 05 size 10 valves

- Design:** Sandwich body valve
- Operating pressure:** max. 350 bar
- Volumetric flow:** max. 100 l/min
- Connection:** ISO/Cetop 05 size 10

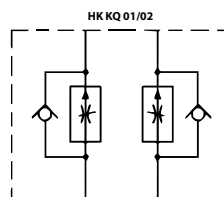

Note: These valves must be set according to the application.

Ordering information: Further sandwich body valves available on request

Identification	acts in channel	Design	Plate height mm	Weight kg
HK KQ 012	A + B	Drain control	50	2,8
HK KQ 013	A	Drain control	50	2,8
HK KQ 014	B	Drain control	50	2,8
HK KQ 022	A + B	Inlet control	50	2,8
HK KQ 023	A	Inlet control	50	2,8
HK KQ 024	B	Inlet control	50	2,8

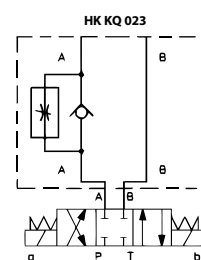
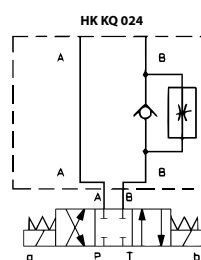
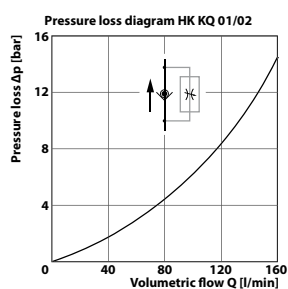
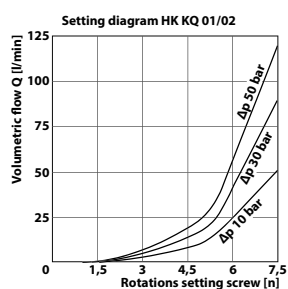
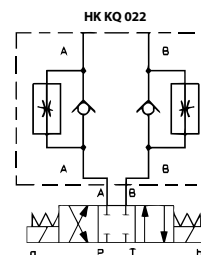
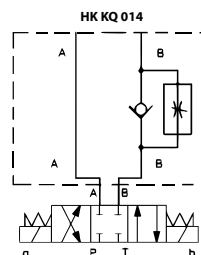
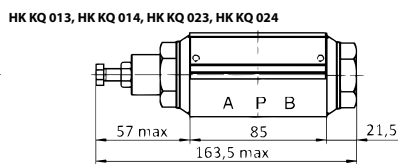
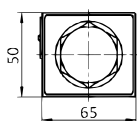
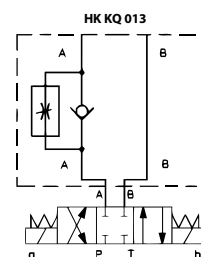
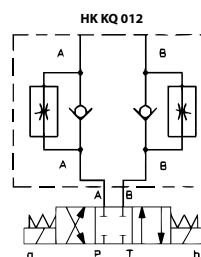
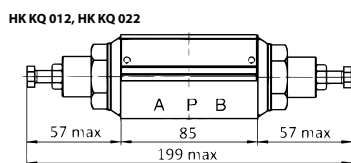
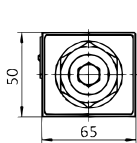

Web: <http://cat.hansa-flex.com/en/HKKQ0102>

HK ZRD 02

Flow control check valve

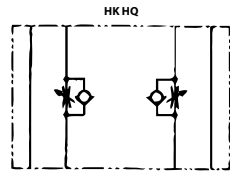

Sandwich body valve for constructing sandwich arrangements with ISO/Cetop 05 size 10 valves

- Design:** Sandwich body valve
- Operating pressure:** max. 315 bar
- Volumetric flow:** max. 160 l/min
- Connection:** ISO/Cetop 05 size 10

Note: These valves must be set according to the application.

Ordering information: Further sandwich body valves available on request

Identification	acts in channel	Design	Plate height mm	Weight kg
HK ZRD ABA02 S0 D1	A + B	Drain control	50	2,8
HK ZRD AA02 S0 D1	A	Drain control	50	2,8
HK ZRD BA02 S0 D1	B	Drain control	50	2,8
HK ZRD ABZ02 S0 D1	A + B	Inlet control	50	2,8
HK ZRD AZ02 S0 D1	A	Inlet control	50	2,8
HK ZRD BZ02 S0 D1	B	Inlet control	50	2,8

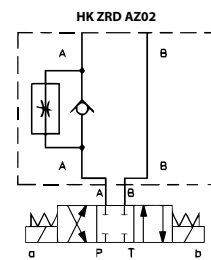
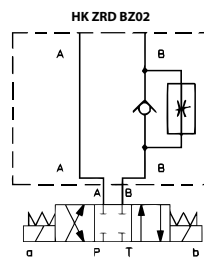
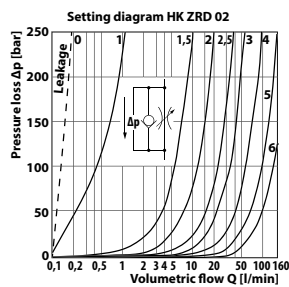
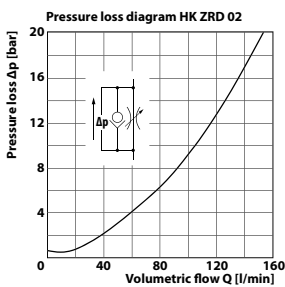
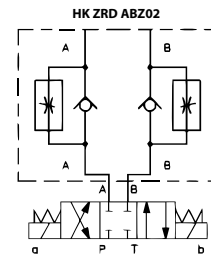
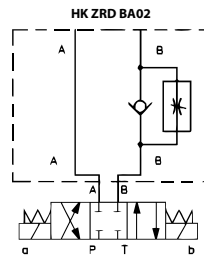
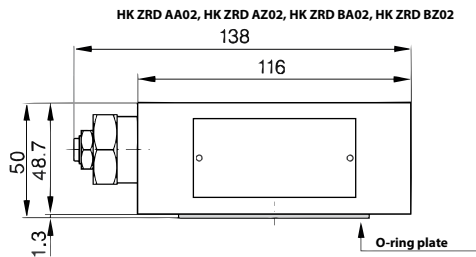
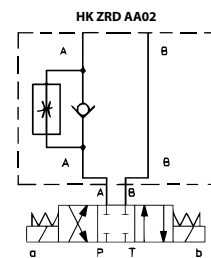
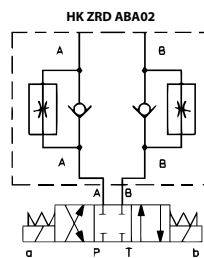
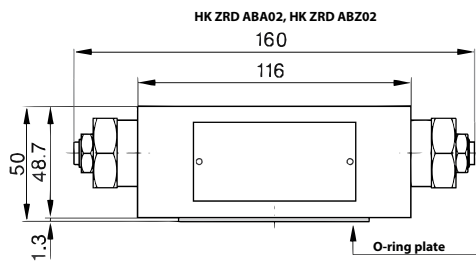

Web: <http://cat.hansa-flex.com/en/HKZRD02>

HK KR 01

Check valve

Sandwich body valve for constructing sandwich arrangements with ISO/Cetop 05 size 10 valves

Design: Sandwich body valve
Operating pressure: max. 350 bar
Volumetric flow: max. 100 l/min
Connection: ISO/Cetop 05 size 10

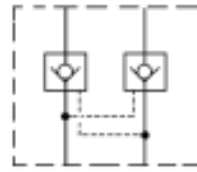

Ordering information: Further sandwich body valves available on request

Identification	acts in channel	Design	Plate height mm	Weight kg
HK KR 011	P	direct-controlled	50	2,8
HK KR 012	A + B	pilot controlled, opening ratio 1:3.3	50	2,8
HK KR 013	A	pilot controlled, opening ratio 1:3.3	50	2,8
HK KR 014	B	pilot controlled, opening ratio 1:3.3	50	2,8

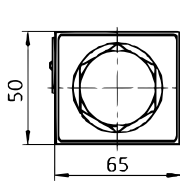

HK KR 012, HK KR 013, HK KR 014

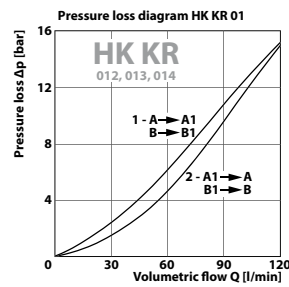
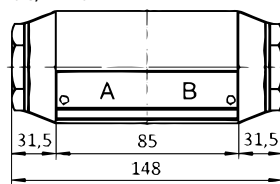

Pressure loss diagram HK KR 01

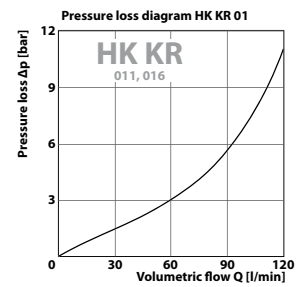

Pressure loss diagram HK KR 01

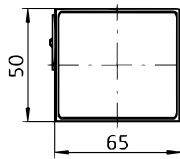

HK KR 011

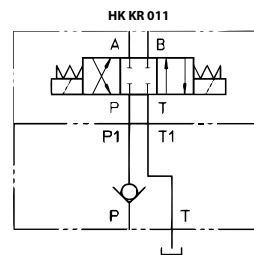

HK KR 011

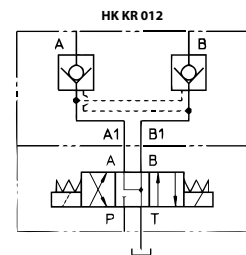

HK KR 012

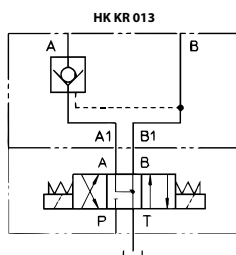

HK KR 013

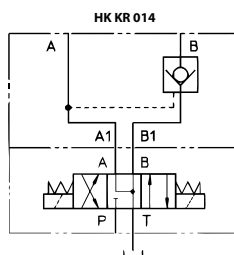

HK KR 014

Web: <http://cat.hansa-flex.com/en/HKKR01>

HK ZRV 02 / ZRE 02

Check valve

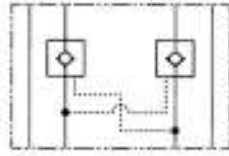

Sandwich body valve for constructing sandwich arrangements with ISO/Cetop 05 size 10 valves

Design: Sandwich body valve
Operating pressure: max. 315 bar
Connection: ISO/Cetop 05 size 10

Note: These valves must be set according to the application.

Ordering information: Further sandwich body valves available on request

Identification	acts in channel	Volumetric flow max. L/min	Design	Plate height mm	Weight kg
HK ZRV P02	P	100,0	direct-controlled	36	2,8
HK ZRE AB02 E1	A + B	120,0	pilot controlled, opening ratio 1: 6	50	2,8
HK ZRE A02 E1	A	120,0	pilot controlled, opening ratio 1: 6	50	2,8
HK ZRE B02 E1	B	120,0	pilot controlled, opening ratio 1: 6	50	2,8

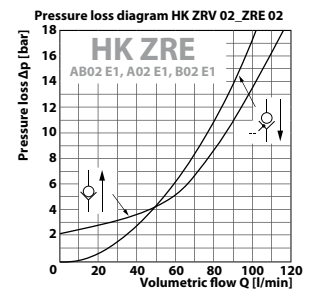
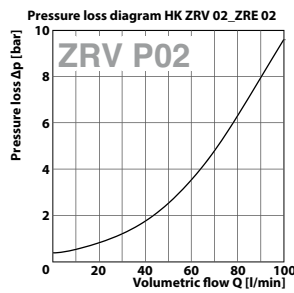
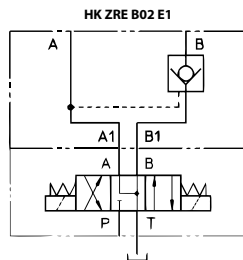
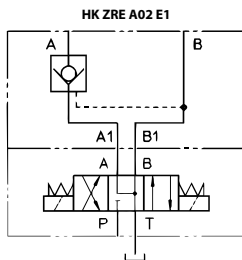
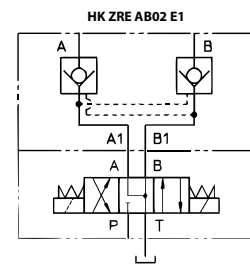
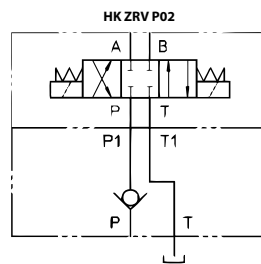
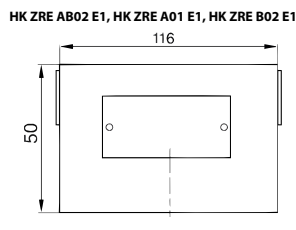
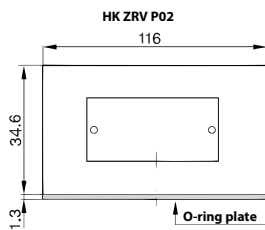

Web: <http://cat.hansa-flex.com/en/HKZRV02ZRE02>

HK ZNS 02

Overcentre valve

Sandwich body valve for constructing sandwich arrangements with ISO/Cetop 05 size 10 valves

Design: Sandwich body valve
Operating pressure: max. 315 bar
Volumetric flow: max. 120 l/min
Connection: ISO/Cetop 05 size 10

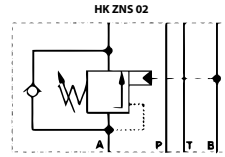

Note: These valves must be set according to the application.

Ordering information: Further sandwich body valves available on request

Identification	acts in channel	Pressure setting range		Design	Plate height mm	Weight kg
		min. bar	max. bar			
HK ZNS A02 2 S0 D1	A	70	175	Opening ratio 1 : 4.5	50	2,8
HK ZNS A02 5 S0 D1	A	140	315	Opening ratio 1 : 4.5	50	2,8
HK ZNS B02 2 S0 D1	B	70	175	Opening ratio 1 : 4.5	50	2,8
HK ZNS B02 5 S0 D1	B	140	315	Opening ratio 1 : 4.5	50	2,8
HK ZNS AB02 2 S0 D1	A + B	70	175	Opening ratio 1 : 4.5	50	2,8
HK ZNS AB02 5 S0 D1	A + B	140	315	Opening ratio 1 : 4.5	50	2,8

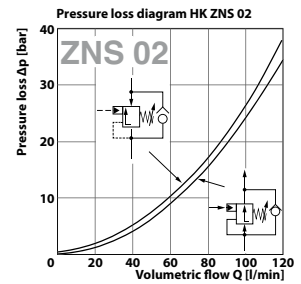
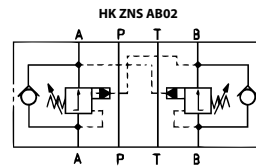
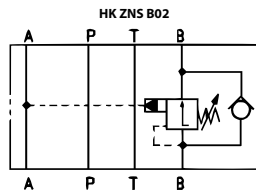
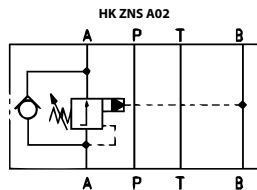
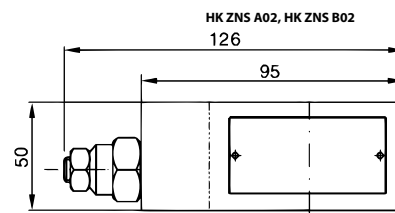
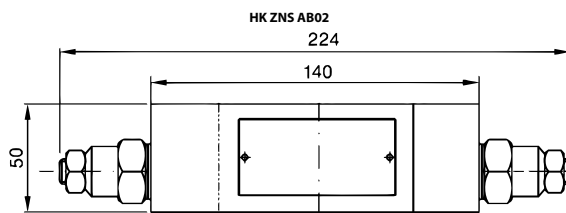

Web: <http://cat.hansa-flex.com/en/HKZNS02>

HK KC 01

2-way pressure balance

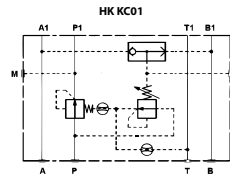

Sandwich body valve for constructing sandwich arrangements with ISO/Cetop 05 size 10 valves
 The pressure balance maintains a constant pressure differential between connection P and connection A or B of the valve, to ensure that a constant flow rate is maintained in the event of pressure variations. The control pressure is diverted by the built-in shuttle valve.

- Design:** Sandwich body valve, pilot-controlled
- Operating pressure:** max. 350 bar
- Volumetric flow:** max. 100 l/min
- Connection:** ISO/Cetop 05 size 10

Note: These valves must be set according to the application.

Ordering information: Further sandwich body valves available on request

Identification	acts in channel	Pressure setting range min. bar	Pressure setting range max. bar	Plate height mm	Weight kg
HK KC 011 30	P	5	35	60	2,8

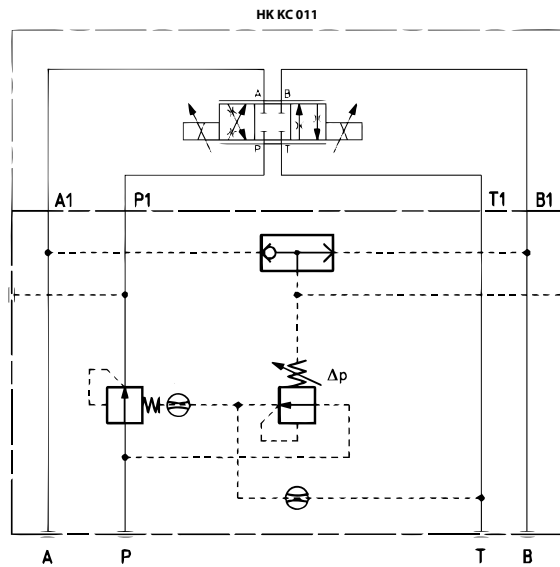
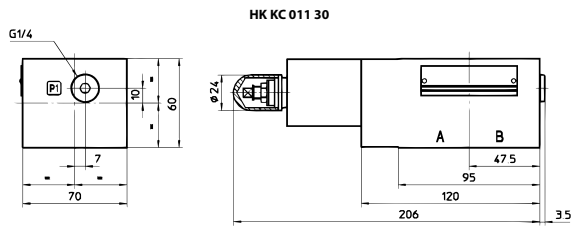

Web: <http://cat.hansa-flex.com/en/HKKC01>

HK KS 01

Pressure sequence valve

Sandwich body valve for constructing sandwich arrangements with ISO/Cetop 05 size 10 valves

- Design:** Sandwich body valve, pilot-controlled
- Operating pressure:** max. 350 bar
- Volumetric flow:** max. 80 l/min
- Connection:** ISO/Cetop 05 size 10

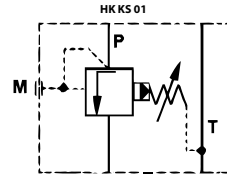

Note: These valves must be set according to the application.

Ordering information: Further sandwich body valves available on request

Identification	acts in channel	Pressure setting range min. bar	Pressure setting range max. bar	Plate height mm	Weight kg
HK KS 011 210	P	8	210	50	3,0

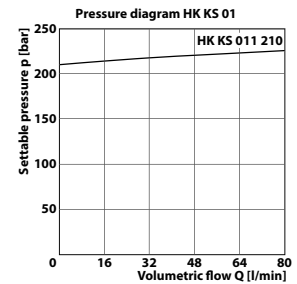
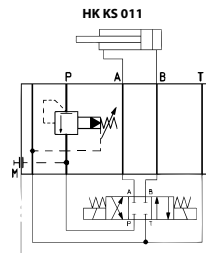
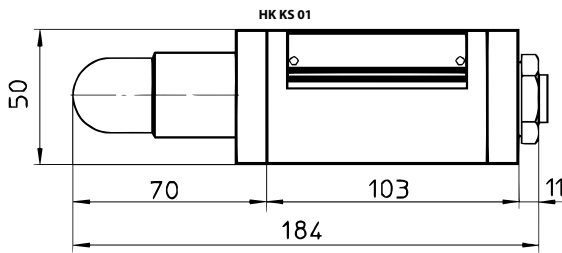

Web: <http://cat.hansa-flex.com/en/HKKS01>

HK BA 310

Sandwich body with measurement connection

Sandwich body valve for constructing sandwich arrangements with ISO/Cetop 05 size 10 valves

- Design:** Sandwich body valve, 2x G1/2" measuring connections
- Scope of supply:** incl. O-rings (5x OR 12.42 x 1.78 / 70 Sh)
- Operating pressure:** max. 350 bar
- Connection:** ISO/Cetop 05 size 10

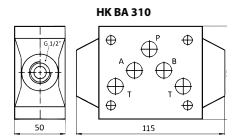

Ordering information: Further sandwich body valves available on request

Identification	acts in channel	Plate height mm	Weight kg
HK BA 310 AB	A + B	50	0,8
HK BA 310 PT	P + T	50	0,6

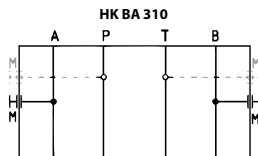

Web: <http://cat.hansa-flex.com/en/HKBA310>

HK GEH ZP NG10 KH

Valve housing ZP NG10 with ball valve

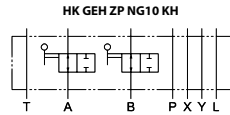
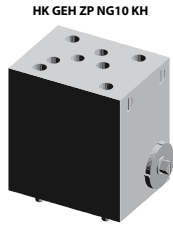

Sandwich body valve with shut-off ball valves for constructing sandwich arrangements with ISO/Cetop 05 NG10 valves
 This sandwich plate allows all the components above it to be shut off – with no pressure relief or emptying and without adversely affecting the rest of the circuit.

- Design:** Sandwich body valve, Ball valve in A+B
- Scope of supply:** incl. 1x hand lever for ball valve
- Operating pressure:** max. 315 bar
- Volumetric flow:** max. 120 l/min
- Connection:** ISO/Cetop 05 size 10

Ordering information: Other designs available on request

Identification	acts in channel	Plate height mm	Weight kg
HK ZP NG10 KH AB	A + B	100	4,5

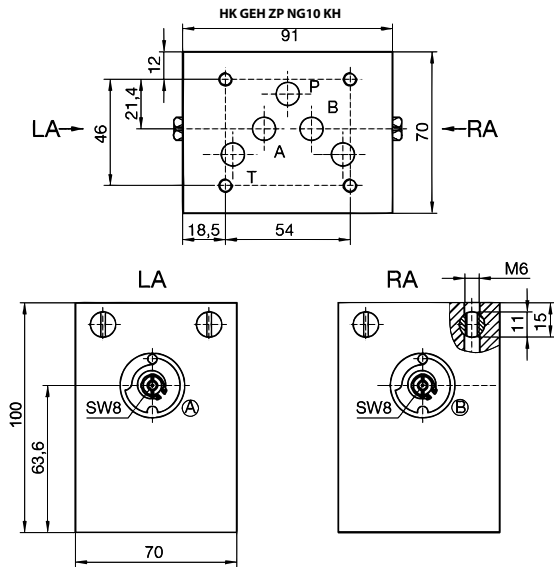

Web: <http://cat.hansa-flex.com/en/HKGEHZPNG10KH>

HK ZP 16 DB

Pressure relief valve

Sandwich body valve for constructing sandwich arrangements with ISO/Cetop 07 size 16 valves

Design: Sandwich body valve, pilot-controlled
Operating pressure: max. 350 bar
Volumetric flow: max. 230 l/min
Connection: ISO/Cetop 07 NG16

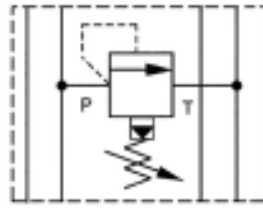

Note: These valves must be set according to the application.

Ordering information: Further sandwich body valves available on request

Identification	acts in channel	Pressure setting range		Plate height mm	Weight kg
		min. bar	max. bar		
HK ZP 16 DB 12 P 15	P	7	105	40	3,4
HK ZP 16 DB 12 P 50	P	35	350	40	3,4
HK ZP 16 DB 12 A 15	A	7	105	40	3,4
HK ZP 16 DB 12 A 50	A	35	350	40	3,4

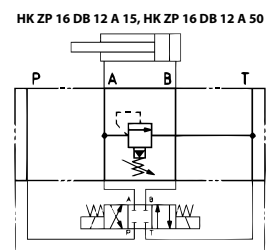
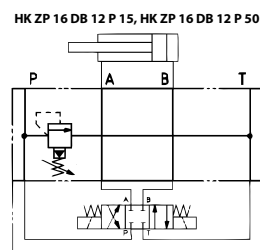
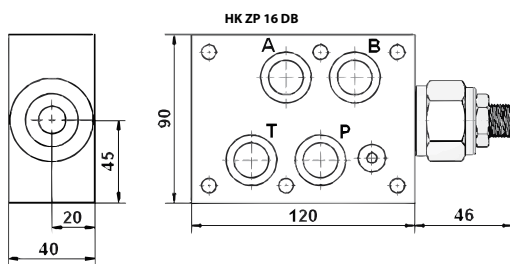

Web: <http://cat.hansa-flex.com/en/HKZP16DB>

HK JPR2

Check valve

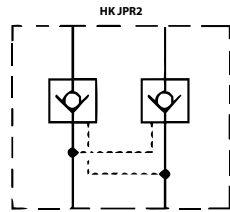

Sandwich body valve for constructing sandwich arrangements with ISO/Cetop 07 size 16 valves

Design: Sandwich body valve
Operating pressure: max. 350 bar
Volumetric flow: max. 160 l/min
Connection: ISO/Cetop 07 NG16

Ordering information: Further sandwich body valves available on request

Identification	acts in channel	Design	Plate height mm	Weight kg
HK JPR 212	A + B	pilot controlled, opening ratio 1: 13.6	60	4,4
HK JPR 213	A	pilot controlled, opening ratio 1: 13.6	60	4,4
HK JPR 214	B	pilot controlled, opening ratio 1: 13.6	60	4,4

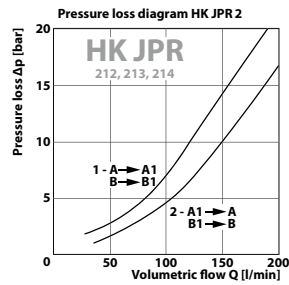
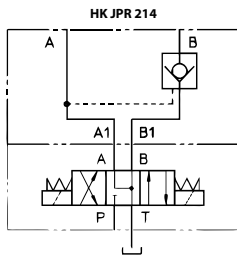
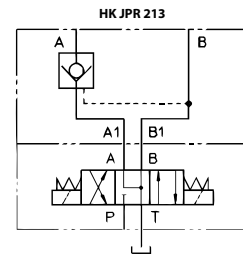
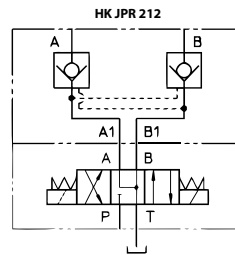
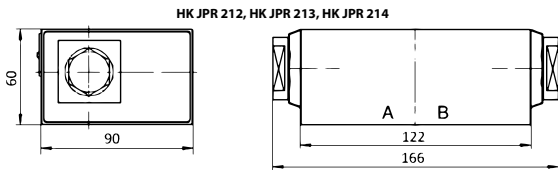

Web: <http://cat.hansa-flex.com/en/HKJPR2>

Flow control check valve

Sandwich body valve for constructing sandwich arrangements with ISO/Cetop 07 size 16 valves

- Design:** Sandwich body valve
- Operating pressure:** max. 350 bar
- Volumetric flow:** max. 160 l/min
- Connection:** ISO/Cetop 07 NG16

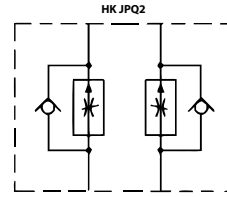

Note: These valves must be set according to the application.

Ordering information: Further sandwich body valves available on request

Identification	acts in channel	Design	Plate height mm	Weight kg
HK JPQ 212	A + B	Drain control	60	4,6
HK JPQ 213	A	Drain control	60	4,6
HK JPQ 214	B	Drain control	60	4,6
HK JPQ 222	A + B	Inlet control	60	4,6
HK JPQ 223	A	Inlet control	60	4,6
HK JPQ 224	B	Inlet control	60	4,6

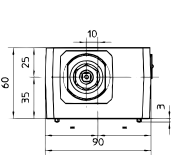

HK JPQ 212, HK JPQ 222

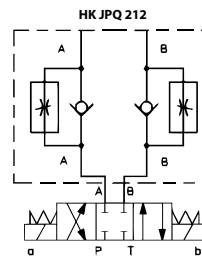
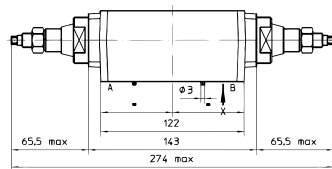

HK JPQ 212

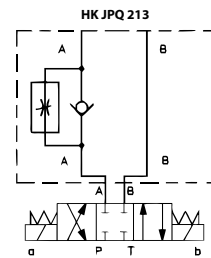

HK JPQ 213

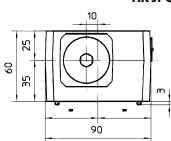

HK JPQ 213, HK JPQ 214, HK JPQ 223, HK JPQ 224

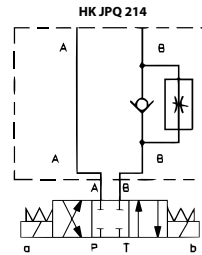
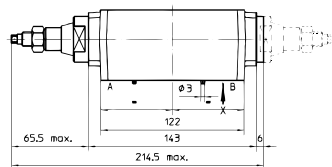

HK JPQ 214

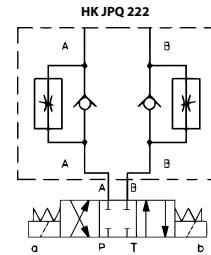

HK JPQ 222

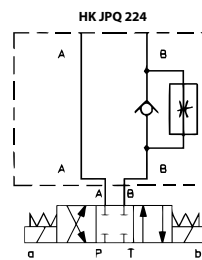
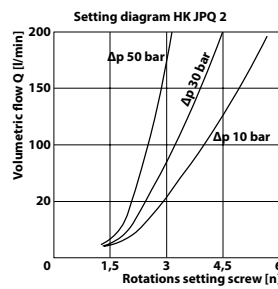
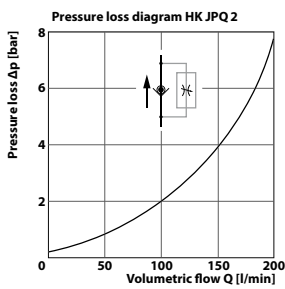

HK JPQ 224

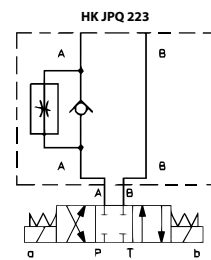

HK JPQ 223

Web: <http://cat.hansa-flex.com/en/HKJPQ2>

HK ZP 25 DB

Pressure relief valve

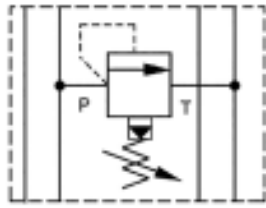

Sandwich body valve for constructing sandwich arrangements with ISO/Cetop 08 size 25 valves

Design: Sandwich body valve, pilot-controlled
Operating pressure: max. 350 bar
Volumetric flow: max. 230 l/min
Connection: ISO/Cetop 08 NG25

Note: These valves must be set according to the application.

Ordering information: Further sandwich body valves available on request

Identification	acts in channel	Pressure setting range		Plate height mm	Weight kg
		min. bar	max. bar		
HK ZP 25 DB 12 P 15	P	7	105	50	11,5
HK ZP 25 DB 12 P 50	P	35	350	50	11,5
HK ZP 25 DB 12 A 15	A	7	105	50	11,5
HK ZP 25 DB 12 A 50	A	35	350	50	11,5

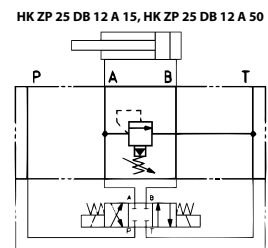
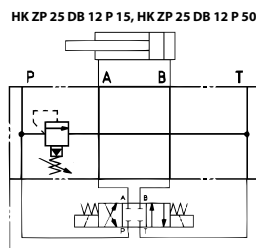
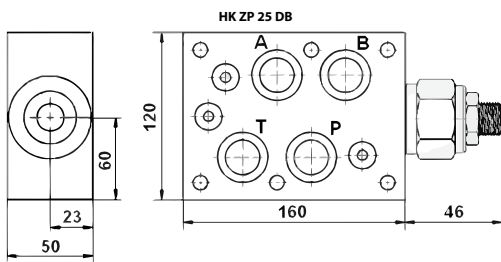

Web: <http://cat.hansa-flex.com/en/HKZP25DB>

HK JPR3

Check valve

Sandwich body valve for constructing sandwich arrangements with ISO/Cetop 08 size 25 valves

Design: Sandwich body valve
Operating pressure: max. 350 bar
Volumetric flow: max. 250 l/min
Connection: ISO/Cetop 08 NG25

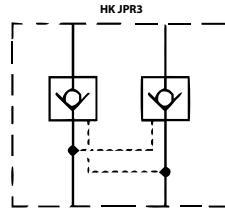

Ordering information: Further sandwich body valves available on request

Identification	acts in channel	Design	Plate height	Weight
			mm	kg
HK JPR 312	A + B	pilot controlled, opening ratio 1: 17.1	80	9,9
HK JPR 313	A	pilot controlled, opening ratio 1: 17.1	80	9,9
HK JPR 314	B	pilot controlled, opening ratio 1: 17.1	80	9,9

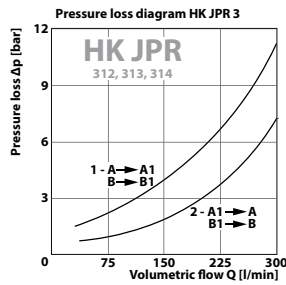
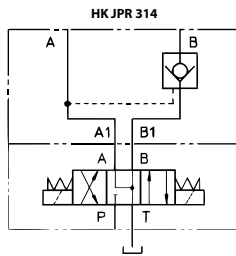
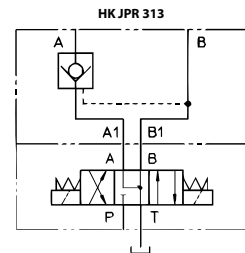
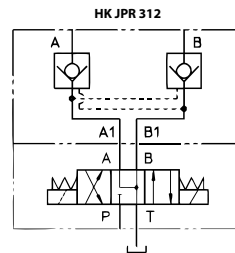
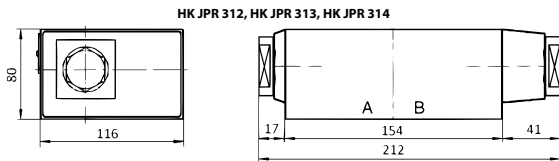

Web: <http://cat.hansa-flex.com/en/HKJPR3>

HK JPQ3

Flow control check valve

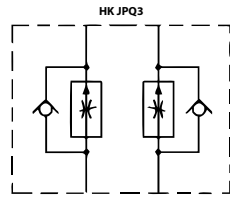

Sandwich body valve for constructing sandwich arrangements with ISO/Cetop 08 size 25 valves

- Design:** Sandwich body valve
- Operating pressure:** max. 350 bar
- Volumetric flow:** max. 250 l/min
- Connection:** ISO/Cetop 08 NG25

Note: These valves must be set according to the application.

Ordering information: Further sandwich body valves available on request

Identification	acts in channel	Design	Plate height mm	Weight kg
HK JPQ 312	A + B	Drain control	80	10,7
HK JPQ 313	A	Drain control	80	10,7
HK JPQ 314	B	Drain control	80	10,7
HK JPQ 322	A + B	Inlet control	80	10,7
HK JPQ 323	A	Inlet control	80	10,7
HK JPQ 324	B	Inlet control	80	10,7

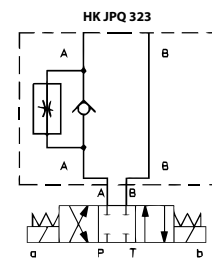
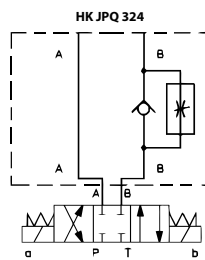
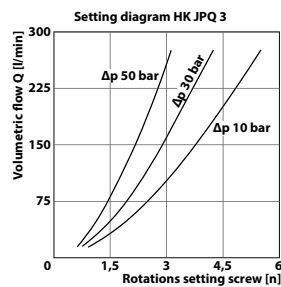
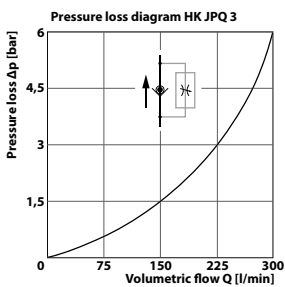
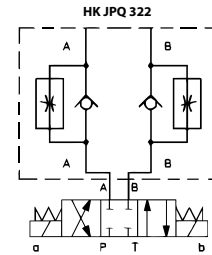
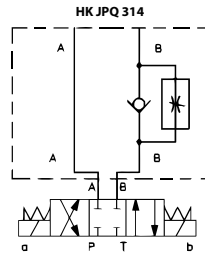
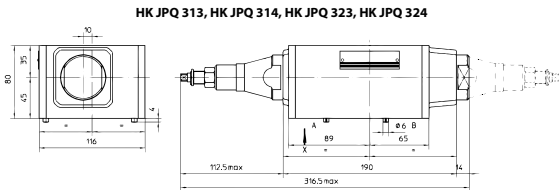
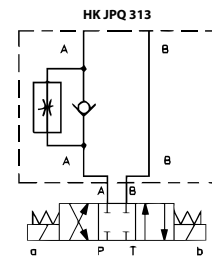
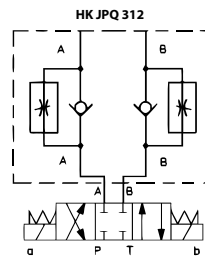
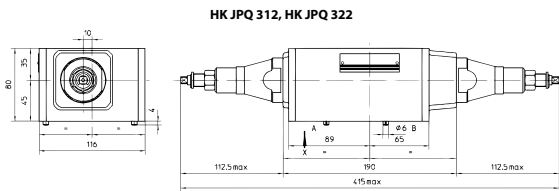

Web: <http://cat.hansa-flex.com/en/HKJPQ3>

HK BA 20 NG6

Single connection plate NG6

Scope of supply: incl. screw set (4x M5 x 50)

Material: Material: Steel (350 bar)

Connection: ISO/Cetop 03 size 6



Note: Further sub-bases available on request

Identification	Stations	Connections A + B	Connections P + T	Height mm	Width mm	Length mm	Weight kg
HK BA 202	Single connection	G 3/8"-bottom	G 3/8"-bottom	35	72	102	1,2
HK BA 204	Single connection	G 3/8"-side	G 3/8"-bottom	53	80	104	1,8

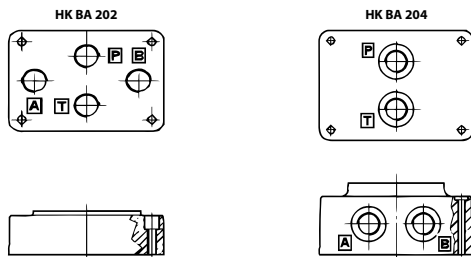

Web: <http://cat.hansa-flex.com/en/HKBA20NG6>

HK BA 214 NG6

Serial connection plate NG6



Material: Material: Steel (350 bar)
Connection: ISO/Cetop 03 size 6

1

Note: Further sub-bases available on request

Identification	Stations	Connections A + B	Connections P + T	Height mm	Width mm	Length mm	Weight kg
HK BA 214 2		G 3/8"-side	G 1/2"-end face	71	71	120	3,7
HK BA 214 3		G 3/8"-side	G 1/2"-end face	71	71	170	5,3
HK BA 214 4		G 3/8"-side	G 1/2"-end face	71	71	220	6,9
HK BA 214 5		G 3/8"-side	G 1/2"-end face	71	71	270	8,5
HK BA 214 6		G 3/8"-side	G 1/2"-end face	71	71	320	10,1
HK BA 214 7		G 3/8"-side	G 1/2"-end face	71	71	370	11,7
HK BA 214 8		G 3/8"-side	G 1/2"-end face	71	71	420	13,3
HK BA 214 9		G 3/8"-side	G 1/2"-end face	71	71	470	14,9
HK BA 214 10		G 3/8"-side	G 1/2"-end face	71	71	520	16,5

HK BA 214 NG6

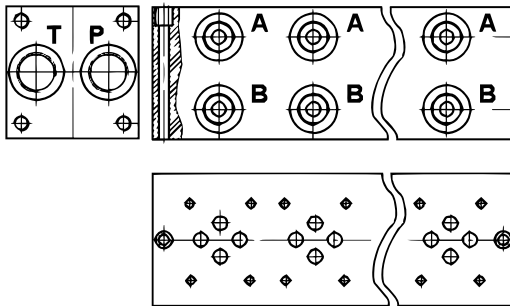

Web: <http://cat.hansa-flex.com/en/HKBA214NG6>

HK MRSL NG6

Single connection plate NG6

Material: Material: Steel (350 bar)
Connection: ISO/Cetop 03 size 6



Note: Depth of the M5 threaded bores for valve mounting: 10 mm
 Further sub-bases available on request

Identification	Stations	Connections A + B	Connections P + T	Height mm	Width mm	Length mm	Weight kg
HK MRSL 3 38	Single connection	G 3/8"-side	G 3/8"-side	35	80	80	1,0

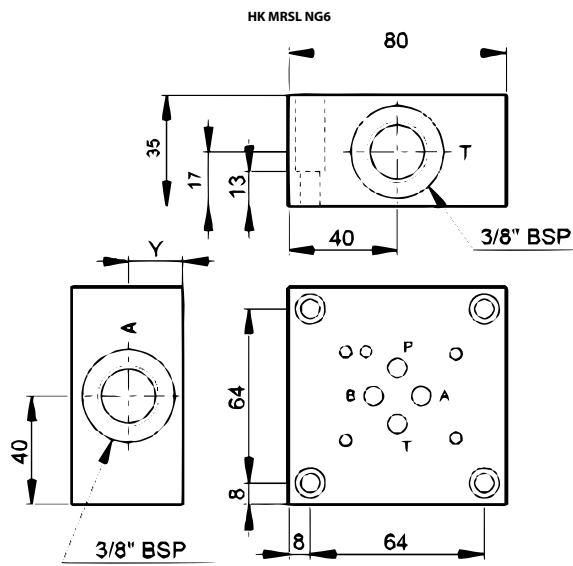

Web: <http://cat.hansa-flex.com/en/HKMRSLNG6>

HK ES3 NG6

Single connection plate with relief valve size 6

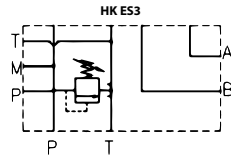

Scope of supply: incl. blind plug, with pressure relief valve
Material: Material: Steel (350 bar)
Connection: ISO/Cetop 03 size 6

Note: These plates have double P- and T-ports. Ports not needed can be closed off with blind plugs.

Identification	Stations	Connections A + B	Connections P + T	Height mm	Width mm	Pressure setting range bar	Length mm	Weight kg
HK ES3 B38 X2 F	Single connection	G 3/8"-side	G 3/8"-side and bottom	65	65	50 - 210	110	3,0
HK ES3 B38 X3 F	Single connection	G 3/8"-side	G 3/8"-side and bottom	65	65	100 - 350	110	3,0

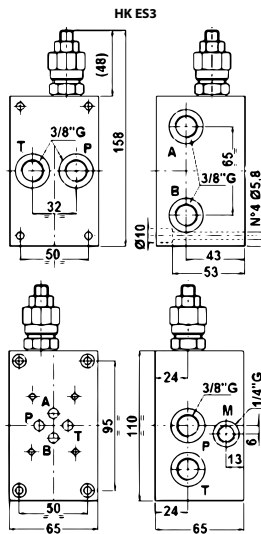

Web: <http://cat.hansa-flex.com/en/HKES3NG6>

HK SP6 BA NG6

Cover panel NG6

Scope of supply: incl. screw set (4x M5 x 30), incl. O-rings (4x OR 8.73 x 1.78 / 70 Sh)

Material: Material: Steel (350 bar)

Connection: ISO/Cetop 03 size 6



1

Note: Further sub-bases available on request

Identification	Stations	Design	Weight kg
HK SP6 BA 40251	Single connection	all connections closed	0,5

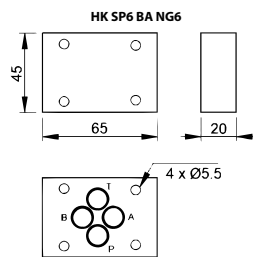

Web: <http://cat.hansa-flex.com/en/HKSP6BANG6>

HK BA 3/4 NG10

Single connection plate NG10



Scope of supply: incl. screw set (4x M6 x 40)
Material: Material: Steel (350 bar)
Connection: ISO/Cetop 05 size 10

Note: Further sub-bases available on request

Identification	Stations	Connections A + B	Connections P + T	Height mm	Width mm	Length mm	Weight kg
HK BA 308	Single connection	G 1/2"-bottom	G 1/2"-bottom	45	103	126	2,5
HK BA 428	Single connection	G 3/4"-bottom	G 3/4"-bottom	60	122	150	5,5
HK BA 434	Single connection	G 3/4"-side	G 3/4"-bottom	60	122	150	6,0

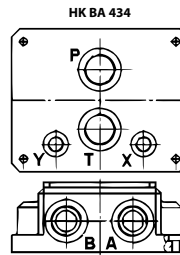
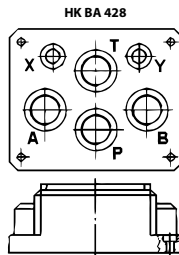
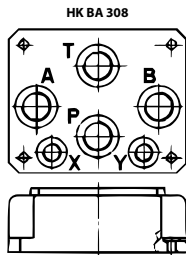

Web: <http://cat.hansa-flex.com/en/HKBA34NG10>

HK BA 314 NG10

Serial connection plate NG10



Material: Material: Steel (350 bar)
Connection: ISO/Cetop 05 size 10

Note: Further sub-bases available on request

Identification	Stations	Connections A + B	Connections P + T	Height mm	Width mm	Length mm	Weight kg
HK BA 314 2		G 3/4"-side		105	105	160	11
HK BA 314 3		G 3/4"-side		105	105	240	15
HK BA 314 4		G 3/4"-side		105	105	320	19
HK BA 314 5		G 3/4"-side		105	105	400	23
HK BA 314 6		G 3/4"-side		105	105	480	24

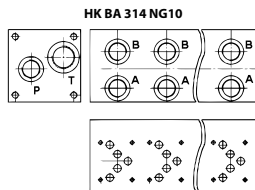

Web: <http://cat.hansa-flex.com/en/HKBA314NG10>

HK ES5 NG10

Single connection plate with relief valve size 10

Scope of supply: incl. blind plug, with pressure relief valve
Material: Material: Steel (350 bar)
Connection: ISO/Cetop 05 size 10

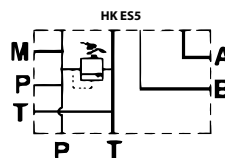

Note: These plates have double P- and T-ports. Ports not needed can be closed off with blind plugs.

Identification	Stations	Connections A + B	Connections P + T	Height mm	Width mm	Pressure setting range bar	Length mm	Weight kg
HK ES5 B34 PL X2 F	Single connection	G 3/4"-side	G 3/4"-side and bottom	74	104	35 - 120	125	7,0
HK ES5 B34 PL X3 F	Single connection	G 3/4"-side	G 3/4"-side and bottom	74	104	80 - 270	125	7,0

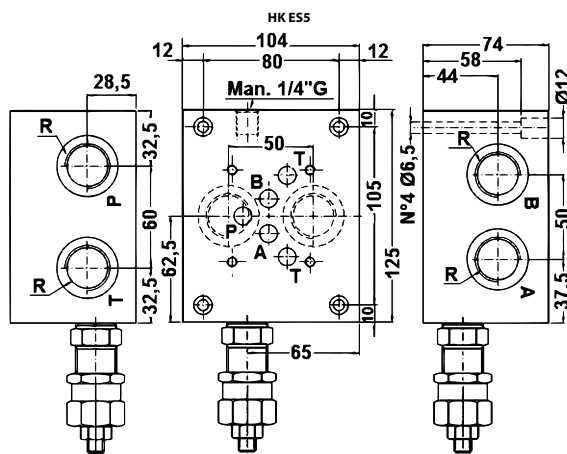

Web: <http://cat.hansa-flex.com/en/HKES5NG10>

HK SP10 BA NG10

Cover panel NG10



Scope of supply: incl. screw set (4x M6 x 40), incl. O-rings (5x OR 12.42 x 1.78 / 70 Sh)

Material: Material: Steel (350 bar)

Connection: ISO/Cetop 05 size 10

Note: Further sub-bases available on request

Identification	Stations	Design	Weight kg
HK SP10 BA 10851	Single connection	all connections closed	1

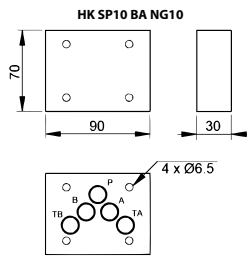

Web: <http://cat.hansa-flex.com/en/HKSP10BANG10>

HK BA 11 NG10 NG6

Reducer plate NG10 - NG6

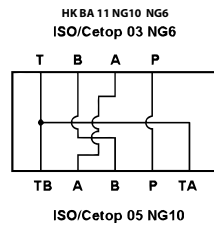

Scope of supply: incl. screw set (4x M6 x 30), incl. O-rings (5x OR 12.42 x 1.78 / 70 Sh)

Material: Material: Steel (350 bar)

Connection: ISO/Cetop 05 size 10

Note: Caution! Connectors A and B are reversed on the size 6 side.
Further sub-bases available on request

Identification	Stations	Height mm	Width mm	Length mm	Weight kg
HK BA 115	Reducer plate NG10 to NG6	30	65	70	1,0

Web: <http://cat.hansa-flex.com/en/HKBA11NG10NG6>

HK BA 4/5 NG16
Single connection plate NG16

Scope of supply: incl. screw set (4x M10 x 50 and 2x M6 x 30)
Material: Material: Steel (350 bar)
Connection: ISO/Cetop 07 NG16

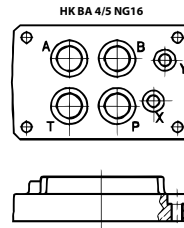

Note: Further sub-bases available on request

Identification	Stations	Connections A + B	Connections P + T	Height mm	Width mm	Length mm	Weight kg
HK BA 418	Single connection	G 3/4"-bottom	G 3/4"-bottom	45	115	179	3,5
HK BA 518	Single connection	G 1"-bottom	G 1"-bottom	65	120	179	8,0

Web: <http://cat.hansa-flex.com/en/HKBA45NG16>

HK EM 207 NG16
Serial connection plate NG16

Material: GG25 (220 bar)
Connection: ISO/Cetop 07 NG16



Note: Further sub-bases available on request

Identification	Stations	Connections A + B	Connections P + T	Height mm	Width mm	Length mm	Weight kg
HK EM 207 2Y		G 1"-bottom	G 1.1/4"-side	125	156	270	35,0
HK EM 207 3Y		G 1"-bottom	G 1.1/4"-side	125	156	395	53,0

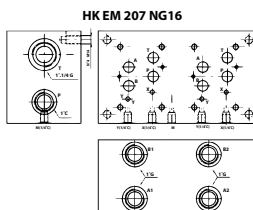

Web: <http://cat.hansa-flex.com/en/HKEM207NG16>

HK BA 6 NG25

Single connection plate NG25

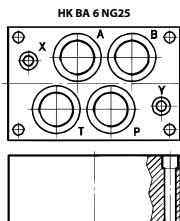

Scope of supply: incl. screw set (6x M12 x 50)
Material: Material: Steel (350 bar)
Connection: ISO/Cetop 08 NG25

Note: Further sub-bases available on request

Identification	Stations	Connections A + B	Connections P + T	Height mm	Width mm	Length mm	Weight kg
HK BA 618	Single connection	G 1.1/4"-bottom	G 1.1/4"-bottom	80	135	205	13,5

Web: <http://cat.hansa-flex.com/en/HKBA6NG25>

HK EM 208 NG25

Serial connection plate NG25



Material: GG25 (220 bar)
Connection: ISO/Cetop 08 NG25

Note: Further sub-bases available on request

Identification	Stations	Connections A + B	Connections P + T	Height mm	Width mm	Length mm	Weight kg
HK EM 208 2Y		G 1.1/4"-bottom	G 1.1/2"-side	150	200	295	62,0
HK EM 208 3Y		G 1.1/4"-bottom	G 1.1/2"-side	150	200	421	90,0

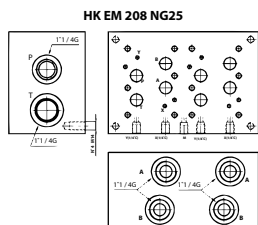

Web: <http://cat.hansa-flex.com/en/HKEM208NG25>

Flow control valve for plate mounting Cetop

Flow rate is kept constant by a pressure balance
 An integrated bypass non-return valve in the 2-way version permits flow in the opposite direction
 Setting of the flow rate by means of adjustment knob

Design: HK QV 06 - directly controlled
Operating pressure: max. 250 bar
Connection: ISO/Cetop 03 NG6 (only P + T)
Mounting: 4 No. hex. socket head screw M5x70 12.9

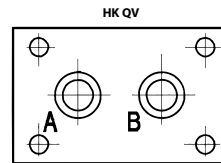

Identification	Connections	Control range min.	Control range max.	max. return flow B->A max.	Design	Pressure difference Δp	Weight
		L/min	L/min	L/min		bar	
HK QV 06 1	ISO/Cetop 03-2 NG6	0,1	1,5	24	2-way	3	1,2
HK QV 06 6	ISO/Cetop 03-2 NG6	0,1	6,0	24	2-way	3	1,2
HK QV 06 11	ISO/Cetop 03-2 NG6	0,1	11,0	24	2-way	5	1,2
HK QV 06 16	ISO/Cetop 03-2 NG6	0,1	16,0	24	2-way	7	1,2
HK QV 06 24	ISO/Cetop 03-2 NG6	0,1	24,0	24	2-way	8	1,2

Δp = min. pressure differential for control function

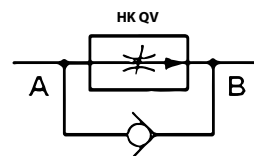
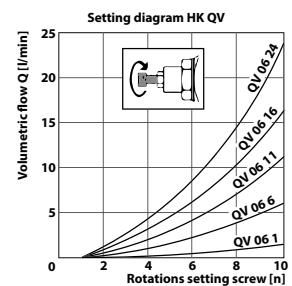
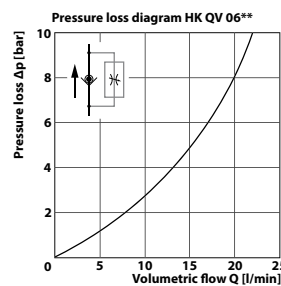
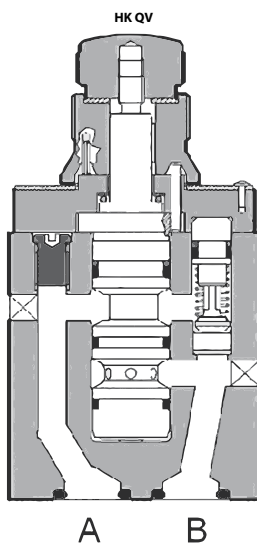

Web: <http://cat.hansa-flex.com/en/HKQV>

Accessories:

HK BHQ - Connection plate for flow control valve QV
HK BA QV - Mounting plate for flow control valve QV
HK M HK QV - Screw set for flow control valve Type HK QV
HK DHQ - High speed/creep speed unit for flow control valve QV

HK BHQ

Connection plate for flow control valve QV

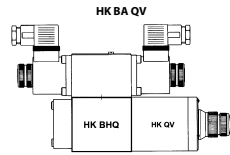

The HK BHQ version permits the modular installation of HK QV 06 valves as sandwich plate with ISO/Cetop 03 hole pattern.

- Scope of supply:** incl. set of screws
- Operating pressure:** max. 250 bar
- Connection:** ISO/Cetop 03 size 6

Identification	acts in channel	Design	Scope of supply	Weight kg
HK BHQ 011	P	without cover plate, drilled on one side	incl. screw set (4x M5 x 70)	0,7
HK BHQ 012	A + B	without cover plate	incl. screw set (8x M5 x 70)	0,7
HK BHQ 013	A	incl. cover plate	incl. screw set (4x M5 x 70)	0,7
HK BHQ 014	B	incl. cover plate	incl. screw set (4x M5 x 70)	0,7
HK BHQ 016	T	without cover plate, drilled on one side	incl. screw set (4x M5 x 70)	0,7
HK BHQ 022	A + B	without cover plate	incl. screw set (8x M5 x 70)	0,7
HK BHQ 023	A	incl. cover plate	incl. screw set (4x M5 x 70)	0,7
HK BHQ 024	B	incl. cover plate	incl. screw set (4x M5 x 70)	0,7

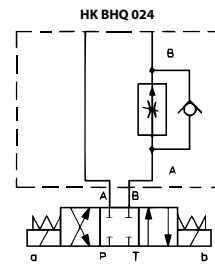
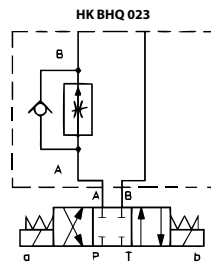
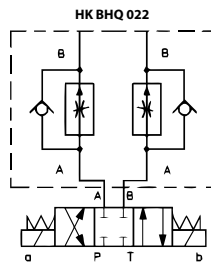
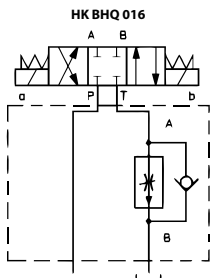
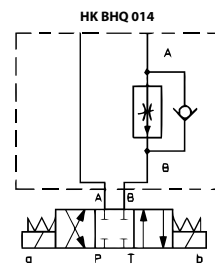
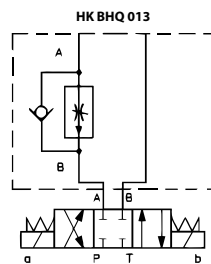
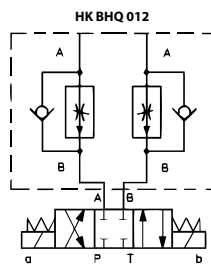
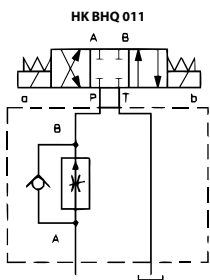

Web: <http://cat.hansa-flex.com/en/HKBHQ>

Accessory for following products:

HK QV - Flow control valve for plate mounting Cetop

High speed/creep speed unit for flow control valve QV

The high speed/creep speed unit consists of sandwich body valve HK DHQ in the bypass (high speed) and flow control valve HK QV 06, which keeps the preset volumetric flow constant with pressure compensation (creep speed). Flow control (creep speed) is assured with switched solenoid
 Max. volumetric flow via the non-return valve: 24 l/min
 Max. free volumetric flow: 36 l/min
 Plate height: 60 mm

Design: Sandwich body valve, as high speed/creep speed unit in combination with type HK QV 06 flow control valve
Scope of supply: with coil, 24 DC
Operating pressure: max. 250 bar
Connection: ISO/Cetop 03 size 6

Note: Max. controlled volumetric flow (depending on the flow control valve used):
 HK QV 06 1: 1.5 l/min
 HK QV 06 6: 6 l/min
 HK QV 06 11: 11 l/min
 HK QV 06 16: 16 l/min
 HK QV 06 24: 24 l/min

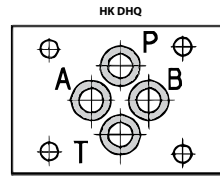

Identification	acts in channel	Design	Weight kg
HK DHQ 011 OI 24DC	P	Inlet control	2,5
HK DHQ 023 OI 24DC	A	Inlet control	2,5
HK DHQ 024 OI 24DC	B	Inlet control	2,5
HK DHQ 013 OI 24DC	A	Drain control	2,5
HK DHQ 014 OI 24DC	B	Drain control	2,5
HK DHQ 016 OI 24DC	T	Drain control	2,5

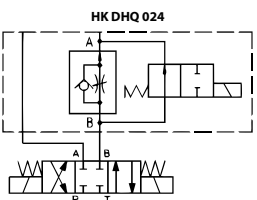
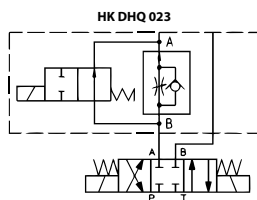
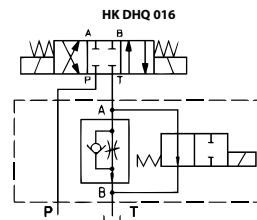
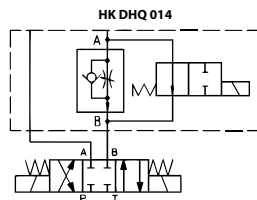
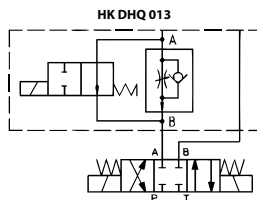
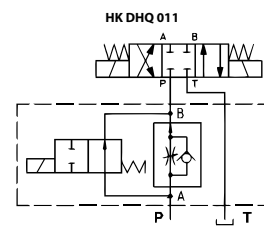
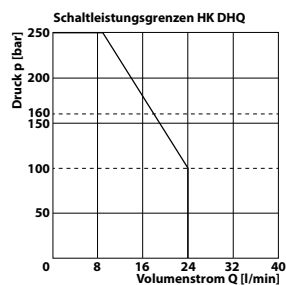
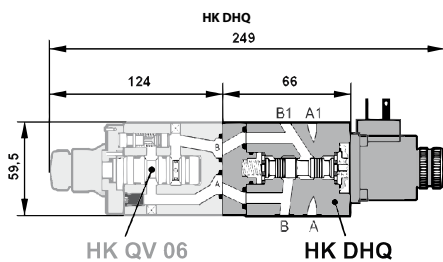

Web: <http://cat.hansa-flex.com/en/HKDHQ>

Accessories:
 HK SP DIN 43650 - Electrical plug for solenoid coil DIN 43650 / ISO 4400

Additional element for following products:
 HK QV - Flow control valve for plate mounting Cetop

HK BA QV

Mounting plate for flow control valve QV



Scope of supply: incl. set of screws
Material: Material: Steel (350 bar)
Connection: ISO/Cetop 03, 06, 07

1

Identification	Connections	for valve type	Stations	Height mm	Width mm	Length mm	Scope of supply	Weight kg
HK BA 302 Q	A+B 1/2" bottom; P+T sealed	HK QV 06	Single connection	53	80	112	incl. screw set (4x M5 x 70)	1,8
HK BA 320	A+B 1/2" bottom	HK QV 10 2	Single connection	35	106	140	incl. screw set (4x M8 x 80)	4,2
HK BA 322	A+P+T 1/2" bottom	HK QV 10 3	Single connection	35	106	140	incl. screw set (4x M8 x 80)	4,2
HK BA 520	A+B 1" bottom	HK QV 20 2	Single connection	45	130	180	incl. screw set (4x M10 x 80)	5,5
HK BA 522	A+P+T 1" bottom	HK QV 20 3	Single connection	45	130	180	incl. screw set (4x M10 x 80)	5,5

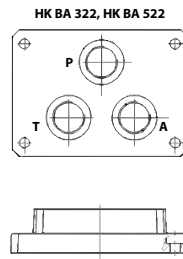
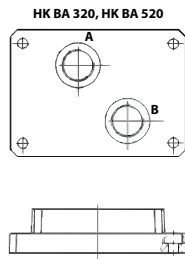
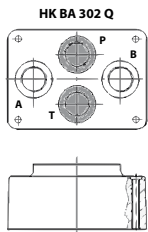

Web: <http://cat.hansa-flex.com/en/HKBAQV>

Accessory for following products:
HK QV - Flow control valve for plate mounting Cetop

Non-return valve for plate mounting Cetop P

Design: pilot-controlled
Material: Steel
Operating pressure: max. 315 bar
Volumetric flow: max. 500 l/min
Connection: ISO/Cetop P

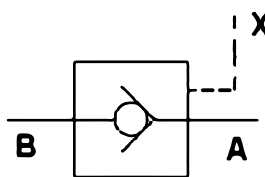

Note: Mounting: 4 No. Allen screws M10x45 for HK AGRL 10 / 20; 4 No. Allen screws M10x100 for HK AGRL 32

Identification	Flow rate max. L/min	Pilot control pressure ratio	Design	Weight kg
HK AGRL 10	160	2.5	ISO/Cetop 06P	4,0
HK AGRL 20	300	2.1	ISO/Cetop 08P	7,0
HK AGRL 32	500	2.55	ISO/Cetop 10P	14,8

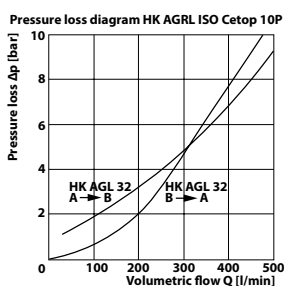
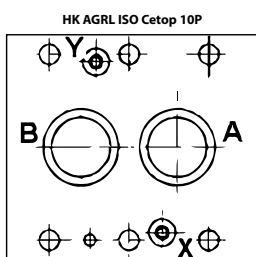
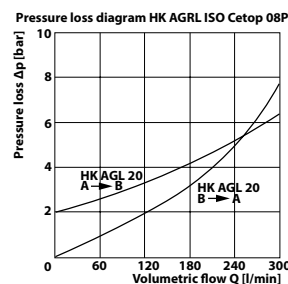
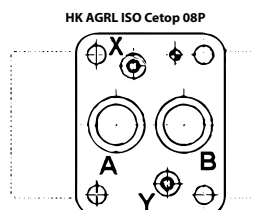
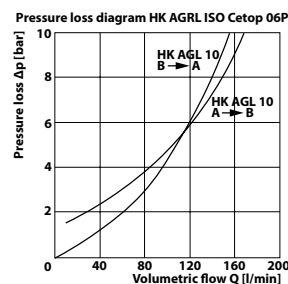
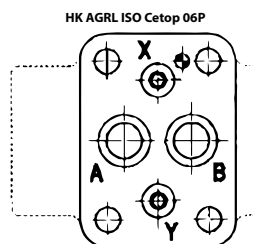
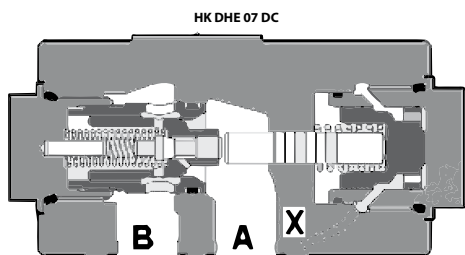

Web: <http://cat.hansa-flex.com/en/HKAGRL>

Accessories:
 HK BA AGRL - Mounting plate for non-return valve AGRL
 HK M HK AGRL - Screw kit for non-return valve Type HK AGRL

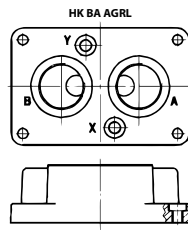
HK BA AGRL**Mounting plate for non-return valve AGRL**

Scope of supply: incl. set of screws
Material: Material: Steel (350 bar)
Connection: ISO/Cetop P

Identification	for valve type	Stations	Connections	Height mm	Width mm	Length mm	Scope of supply	Weight kg
HK BA 305	HK AGL 10	Single connection	A+B 1/2" bottom; X+Y 1/4" bottom	30	90	113	incl. screw set (4x M10 x 45)	1,0
HK BA 505	HK AGL 20	Single connection	A+B 1" bottom; X+Y 1/4" bottom	42	103	133	incl. screw set (4x M10 x 45)	2,0
HK BA 705 A	HK AGL 32	Single connection	A+B 1.1/2" bottom; X+Y 1/4" bottom	60	121	184	incl. screw set (6x M10 x 100)	7,5

Web: <http://cat.hansa-flex.com/en/HKBAAGRL>

Accessory for following products:

HK AGRL - Non-return valve for plate mounting Cetop P

Pressure relief valve with SAE connector

Pilot-controlled pressure relief valve with damping plunger
 Version with solenoid relief valve for pressure-free circulation of the pump
 see HK REM 24
 Max. volumetric flow 600 l/min
 For mineral- based hydraulic oil or synthetic fluids with comparable
 properties

Design: SAE flange connector (e.g. for direct fitting to pumps)

Scope of supply: incl. SAE flanges and M10 screws

Operating pressure: max. 350 bar

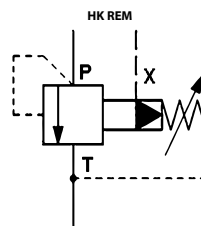

Identification	Connection	Pressure setting range min.	Pressure setting range max.	Volumetric flow max.	Weight
		bar	bar	L/min	kg
HK REM 3 350	SAE flange 3/4"	8	350	200,0	6,6
HK REM 4 210	SAE flange 1"	7	210	400,0	6,8
HK REM 5 210	SAE flange 1.1/4"	7	210	600,0	8,2

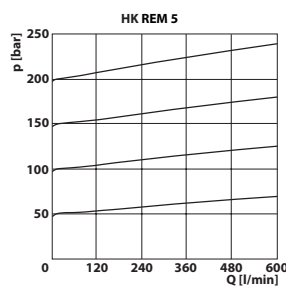
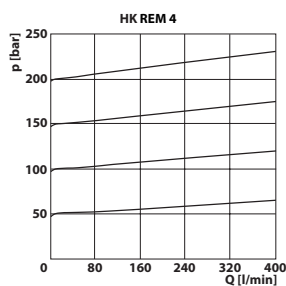
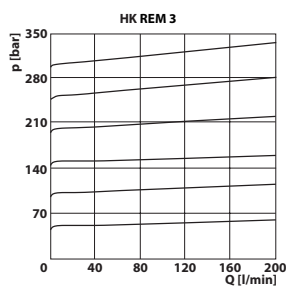

Web: <http://cat.hansa-flex.com/en/HKREM>

HK REM 24

Pressure relief valve with SAE connection and relief valve

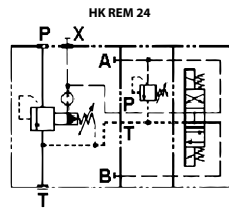

Pilot-controlled pressure relief valve with damping plunger
 2 pressure adjustment ranges (same min / max values)
 Max. volumetric flow 600 l/min
 For mineral-based hydraulic oil or synthetic fluids with comparable properties

Design: SAE flange connector (e.g. for direct fitting to pumps), with magnetic relief valve 24 V; relief with magnet at zero current

Scope of supply: incl. SAE flanges and M10 screws

Operating pressure: max. 350 bar

Note: These valves must be set according to the application.

Identification	Connection	Pressure setting range		Volumetric flow max. L/min	Weight kg
		min. bar	max. bar		
HK REM 3 20 350 350 24	SAE flange 3/4"	8	350	200,0	9,2
HK REM 4 20 210 210 24	SAE flange 1"	7	210	400,0	9,2
HK REM 5 20 210 210 24	SAE flange 1.1/4"	7	210	600,0	9,2

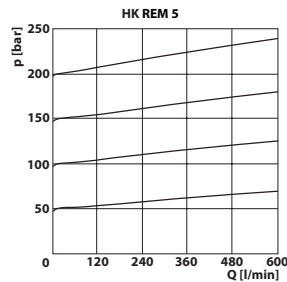
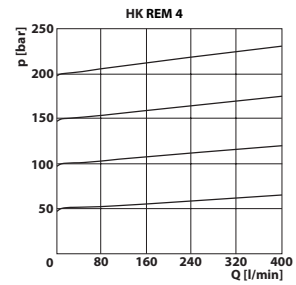
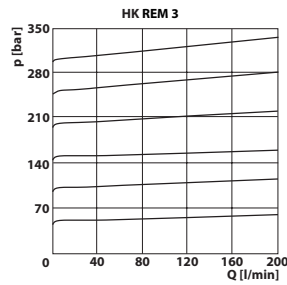
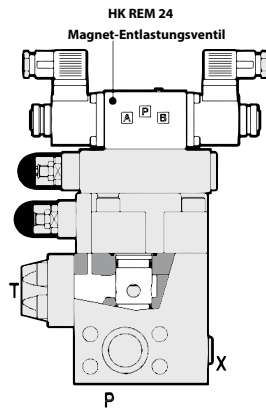

Web: <http://cat.hansa-flex.com/en/HKREM24>

Accessories:

HK SP DIN 43650 - Electrical plug for solenoid coil DIN 43650 / ISO 4400

HK DHZO A

Proportional solenoid-operated directional control valve size 6

Without integrated position transducer (a pcb Type HK EBM AS is required for control)

Completely encapsulated solenoid coils

Response time < 30 ms

Hysteresis < 5%

Design: 4/2-way valve or 4/3-way valve, direct-controlled, for applications in open control loop

Scope of supply: with coil, without plug

Operating pressure: P, A, B: max. 350bar / T: max. 210bar

Connection: ISO/Cetop 03 size 6

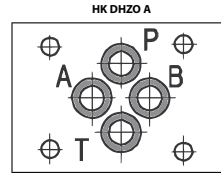

Ordering information: Other designs available on request

Identification	Circuit diagram	Type	Q max. L/min	Overlap	Control	Design	Piston type	Weight kg
HK DHZO A 051 L5		4/2	50	P, A, B, T positive (closed)	linear	Spring return	L5 [A/B/P/T]-[PA/BT]	1,9
HK DHZO A 071 D5		4/3	50	P, A, B, T positive (closed)	progressive, passage A, B in ratio 2:1	Spring return	D5 [PB/AT]-[A/B/P/T]-[PA/BT]	2,6
HK DHZO A 071 S3		4/3	30	P, A, B, T positive (closed)	progressive	spring return to 0	S3 [PB/AT]-[A/B/P/T]-[PA/BT]	2,6
HK DHZO A 071 L5		4/3	50	P, A, B, T positive (closed)	linear	spring return to 0	L5 [PB/AT]-[A/B/P/T]-[PA/BT]	2,6
HK DHZO A 073 D5		4/3	50	P positive (closed); A, B, T negative (open)	progressive, passage A, B in ratio 2:1	spring return to 0	D5 [PB/AT]-[ABT/P]-[PA/BT]	2,6
HK DHZO A 073 S3		4/3	30	P positive (closed); A, B, T negative (open)	progressive	spring return to 0	S3 [PB/AT]-[ABT/P]-[PA/BT]	2,6
HK DHZO A 073 L5		4/3	50	P positive (closed); A, B, T negative (open)	linear	spring return to 0	L5 [PB/AT]-[ABT/P]-[PA/BT]	2,6

Piston type example: [A/B/PT] = [A blocked / B blocked / P+T connected] Qmax - max intake volumetric flow

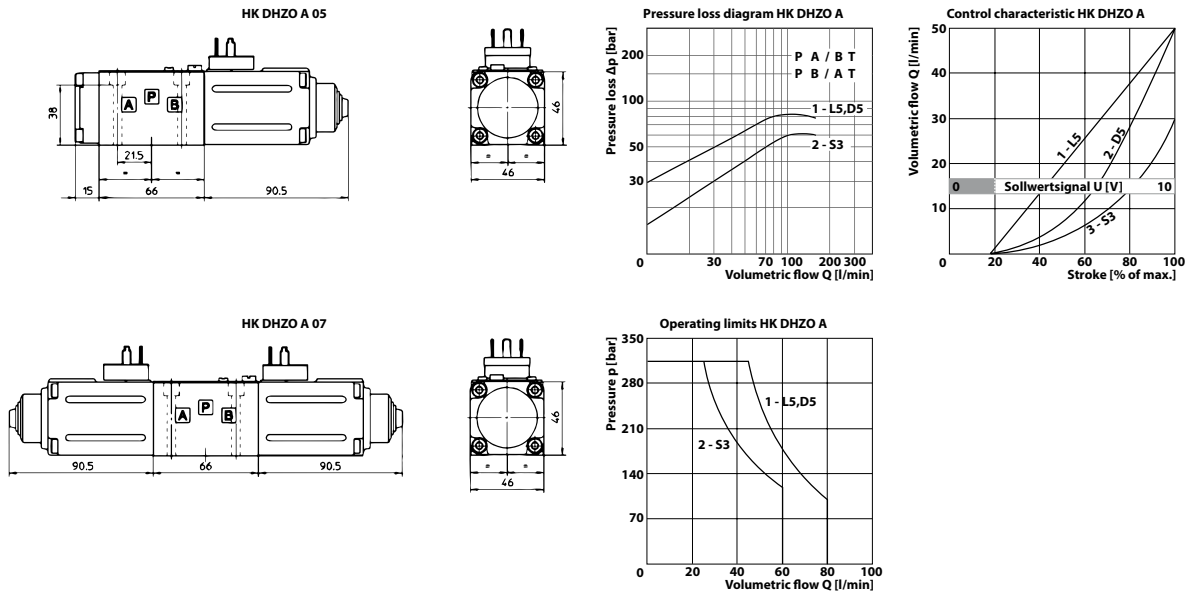

Web: <http://cat.hansa-flex.com/en/HKDHZO A>

Accessories:

HK EBM AS - Proportional amplifier digital

HK SP DIN 43650 - Electrical plug for solenoid coil DIN 43650 / ISO 4400

HK M HK DH - Screw set for NG 6 valves type HK DH / DG4V3

HK DLHZO TE

Proportional solenoid-operated directional control valve size 6

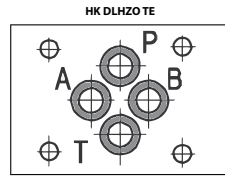

with hardened sleeve for max. overlapping accuracy
 Completely encapsulated solenoid coils
 Response time < 10 ms
 Hysteresis < 0,1%
 Pilot signal 0-10 VDC

Design: 4/3-way valve, direct-controlled, for applications in closed control loop

Scope of supply: without plug, with integrated electronics

Operating pressure: P, A, B: max. 350bar / T: max. 160bar

Volumetric flow: max. 70 l/min (note characteristic curves)

Connection: ISO/Cetop 03 size 6

Note: (*) These 4/3-way valves are switched by only one coil. The off-center Fail-Safe position of the piston is reached by spring return after switching off the voltage.

Ordering information: Other designs available on request

Identification	Circuit diagram	Type	Overlap	Control	Design	Piston type	Weight kg
HK DLHZO TE 040 L71		4/3	Zero	linear	Spring return to Fail-Safe Position (*) L7 [A/B/P/T]-[PB/AT]-[ABPT]-[PA/BT]	2,8	
HK DLHZO TE 040 L73		4/3	Zero	linear	Spring return to Fail-Safe Position (*) L7 [ABT/P]-[PB/AT]-[ABPT]-[PA/BT]	2,8	

Piston type example: [A/B/P/T] = [A blocked / B blocked / P+T connected]

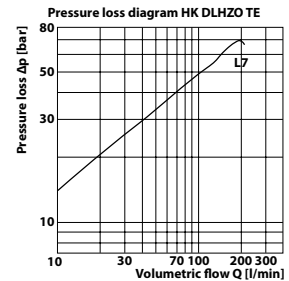
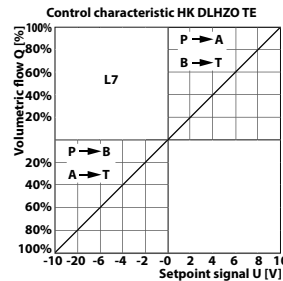
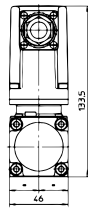
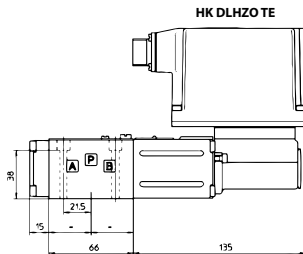

Web: <http://cat.hansa-flex.com/en/HKDLHZOTE>

Accessories:

HK M HK DH - Screw set for NG 6 valves type HK DH / DG4V3

HK SPZ - Electrical connector for proportional valves

HK DKZOR A

Proportional solenoid-operated directional control valve size 10

Without integrated position transducer (a pcb Type HK EBM AS is required for control)

Completely encapsulated solenoid coils

Response time < 40 ms

Hysteresis < 5%

Design: 4/2-way valve or 4/3-way valve, direct-controlled, for applications in open control loop

Scope of supply: with coil, without plug

Operating pressure: P, A, B: max. 315bar / T: max. 210bar

Connection: ISO/Cetop 05 size 10

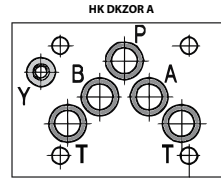

Ordering information: Other designs available on request

Identification	Circuit diagram	Type	Overlap	Volumetric flow max. L/min	Control	Design	Piston type	Weight kg
HK DKZOR A 151 L5		4/2	P, A, B, T positive (closed)	105,0	linear	Spring return	L5 [A/B/P/T]-[PA/BT]	3,8
HK DKZOR A 171 D5		4/3	P, A, B, T positive (closed)	105,0	progressive, passage A, B in ratio 2:1	Spring return	D5 [PB/AT]-[A/B/P/T]-[PA/BT]	4,5
HK DKZOR A 171 S3		4/3	P, A, B, T positive (closed)	80,0	progressive	spring return to 0	S3 [PB/AT]-[A/B/P/T]-[PA/BT]	4,5
HK DKZOR A 171 S5		4/3	P, A, B, T positive (closed)	105,0	progressive	spring return to 0	S5 [PB/AT]-[A/B/P/T]-[PA/BT]	4,5
HK DKZOR A 171 L5		4/3	P, A, B, T positive (closed)	105,0	linear	spring return to 0	L5 [PB/AT]-[A/B/P/T]-[PA/BT]	4,5
HK DKZOR A 173 D5		4/3	P positive (closed); A, B, T negative (open)	105,0	progressive, passage A, B in ratio 2:1	spring return to 0	D5 [PB/AT]-[ABT/P]-[PA/BT]	4,5
HK DKZOR A 173 S3		4/3	P positive (closed); A, B, T negative (open)	80,0	progressive	spring return to 0	S3 [PB/AT]-[ABT/P]-[PA/BT]	4,5
HK DKZOR A 173 L5		4/3	P positive (closed); A, B, T negative (open)	105,0	linear	spring return to 0	L5 [PB/AT]-[ABT/P]-[PA/BT]	4,5

Piston type example: [A/B/PT] = [A blocked / B blocked / P+T connected]

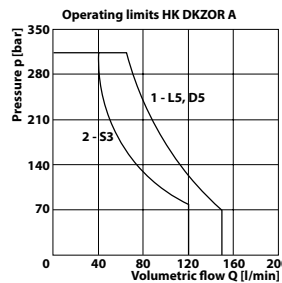
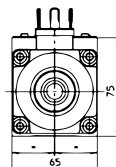
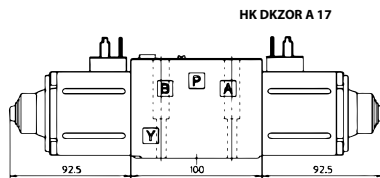
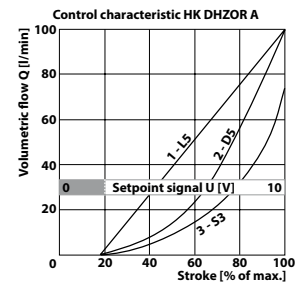
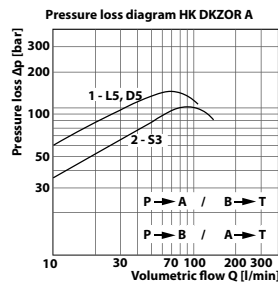
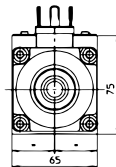
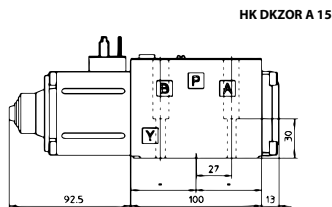

Web: <http://cat.hansa-flex.com/en/HKDKZORA>

Accessories:

HK EBM AS - Proportional amplifier digital

HK SP DIN 43650 - Electrical plug for solenoid coil DIN 43650 / ISO 4400

HK M HK DK - Set of bolts for NG 10 valves types HK DK11/DKE/DG4V5

HK DLKZOR TE

Proportional solenoid-operated directional control valve size 10

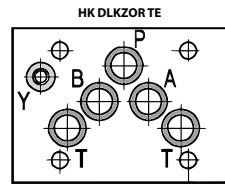

with hardened sleeve for max. overlapping accuracy
 Completely encapsulated solenoid coils
 Response time < 15 ms
 Hysteresis < 0,1%
 Pilot signal 0-10 VDC

Design: 4/3-way valve, direct-controlled, for applications in closed control loop

Scope of supply: without plug, with integrated electronics

Operating pressure: P, A, B: max. 315bar / T: max. 160bar

Volumetric flow: max. 160 l/min (note characteristic curves)

Connection: ISO/Cetop 05 size 10

Note: (*) These 4/3-way valves are switched by only one coil. The off-center Fail-Safe position of the piston is reached by spring return after switching off the voltage.

Ordering information: Other designs available on request

Identification	Circuit diagram	Type	Overlap	Control	Design	Piston type	Weight kg
HK DLKZOR TE 140 L71		4/3	Zero	linear	Spring return to Fail-Safe Position (*) L7	[A/B/P/T]-[PB/AT]-[ABPT]-[PA/BT]	4,7
HK DLKZOR TE 140 L73		4/3	Zero	linear	Spring return to Fail-Safe Position (*) L7	[ABT/P]-[PB/AT]-[ABPT]-[PA/BT]	4,7

Piston type example: [A/B/PT] = [A blocked / B blocked / P+T connected]

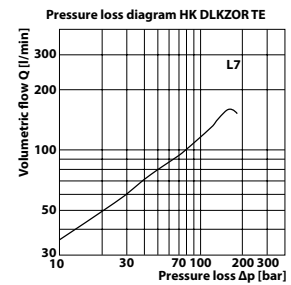
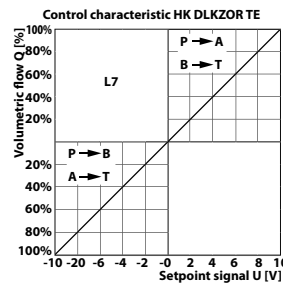
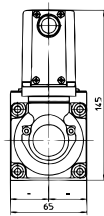
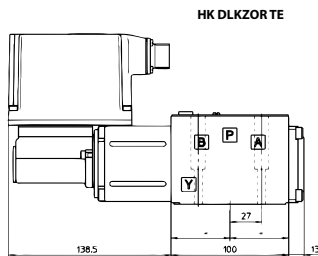

Web: <http://cat.hansa-flex.com/en/HKDLKZORTE>

Accessories:

HK M HK DK - Set of bolts for NG 10 valves types HK DK11/DKE/DG4V5

HK SPZ - Electrical connector for proportional valves

HK HZGO A 031
Proportional pressure reducing valve size 6

Sandwich body valve for constructing sandwich arrangements with ISO/
 Cetop 03 size 6 valves
 Without integrated pressure transducer (a pcb Type HK EBM AS is required
 for control)
 Completely encapsulated solenoid coils
 Plate height: 50 mm
 Response time < 50 ms
 Hysteresis < 2%

Design: Proportional sandwich body valve, pilot-controlled
Scope of supply: with coil, without plug
Operating pressure: max. 315 bar
Volumetric flow: max. 40 l/min
Connection: ISO/Cetop 03 size 6

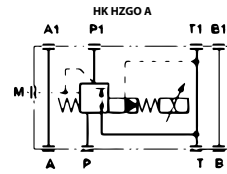

Identification	acts in channel	Pressure setting range min.	Pressure setting range max.	Volumetric flow min.	Volumetric flow max.	Weight
		bar	bar	L/min	L/min	kg
HK HZGO A 031 315	P1	6	315	2,5	40,0	3,8

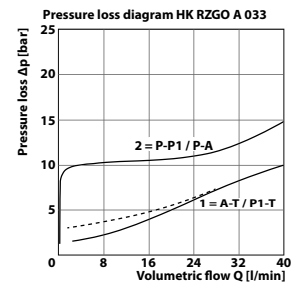
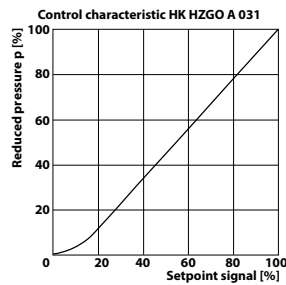
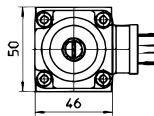
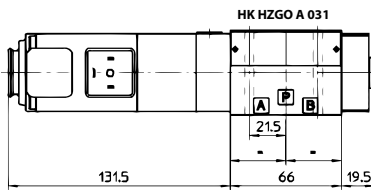

Web: <http://cat.hansa-flex.com/en/HKHZGOA031>

Accessories:

HK EBM AS - Proportional amplifier digital

HK SP DIN 43650 - Electrical plug for solenoid coil DIN 43650 / ISO 4400

HK HZMO A 030

Proportional pressure relief valve size 6

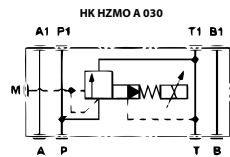

Sandwich body valve for constructing sandwich arrangements with ISO/Cetop 03 size 6 valves
 Without integrated pressure transducer (a pcb Type HK EBM AS is required for control)
 Completely encapsulated solenoid coils
 Plate height: 50 mm
 Response time < 60 ms
 Hysteresis < 1,5%

Design: Proportional sandwich body valve, pilot-controlled
Scope of supply: with coil, without plug
Operating pressure: max. 315 bar
Volumetric flow: max. 40 l/min
Connection: ISO/Cetop 03 size 6

Identification	acts in channel	Pressure setting range		Volumetric flow		Weight
		min. bar	max. bar	min. L/min	max. L/min	
HK HZMO A 030 210	P	6	210	2,5	40,0	2,8
HK HZMO A 030 315	P	6	315	2,5	40,0	2,8

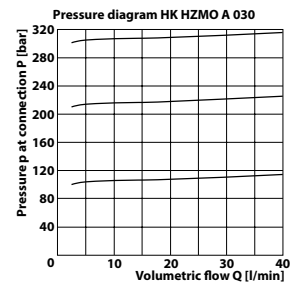
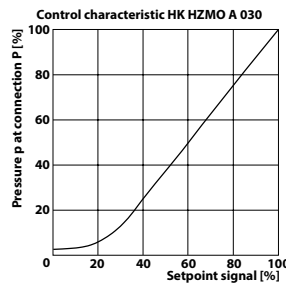
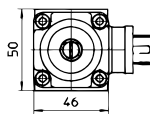
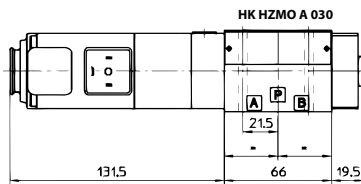

Web: <http://cat.hansa-flex.com/en/HKHZMOA030>

Accessories:

- HK EBM AS - Proportional amplifier digital
- HK SP DIN 43650 - Electrical plug for solenoid coil DIN 43650 / ISO 4400

HK KZGO A 031
Proportional pressure reducing valve size 10

Sandwich body valve for constructing sandwich arrangements with ISO/Cetop 05 size 10 valves
 Without integrated pressure transducer (a pcb Type HK EBM AS is required for control)
 Completely encapsulated solenoid coils
 Plate height: 50 mm
 Response time < 80 ms
 Hysteresis < 2%

Design: Proportional sandwich body valve, pilot-controlled
Scope of supply: with coil, without plug
Operating pressure: max. 315 bar
Volumetric flow: max. 100 l/min
Connection: ISO/Cetop 05 size 10

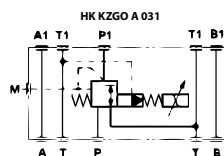

Identification	acts in channel	Pressure setting range min.	Pressure setting range max.	Volumetric flow min.	Volumetric flow max.	Weight
HK KZGOA 031 315	P1	bar 6	bar 315	L/min 3,0	L/min 100,0	kg 4,4

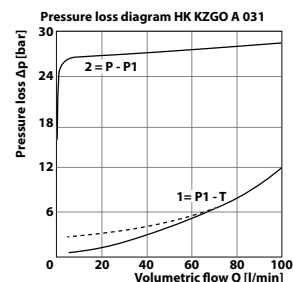
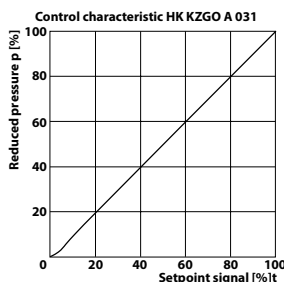
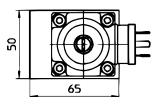
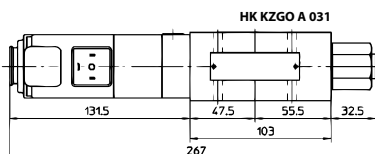

Web: <http://cat.hansa-flex.com/en/HKKZGOA031>

Accessories:
 HK EBM AS - Proportional amplifier digital
 HK SP DIN 43650 - Electrical plug for solenoid coil DIN 43650 / ISO 4400

HK RZMO AE 030
Proportional pressure relief valve size 6

with integrated electronics
 Response time < 60 ms
 Hysteresis < 1,5%
 Pilot signal 0-10 VDC

Design: Proportional plate mounting valve, pilot-controlled
Scope of supply: with integrated electronics, without plug
Operating pressure: max. 315 bar
Volumetric flow: max. 40 l/min
Connection: ISO/Cetop 03 size 6

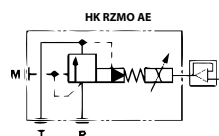

Identification	acts in channel	Pressure setting range min.	Pressure setting range max.	Volumetric flow min.	Volumetric flow max.	Weight
HK RZMO AE 030 210	P	bar 6	bar 210	L/min 2,5	L/min 40,0	kg 2,8
HK RZMO AE 030 315	P	bar 6	bar 315	L/min 2,5	L/min 40,0	kg 2,8

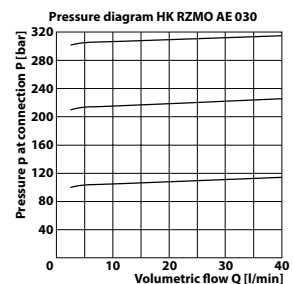
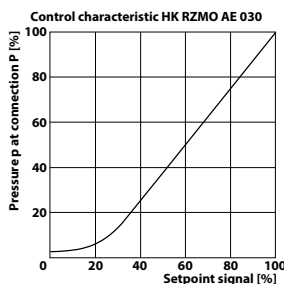
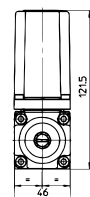
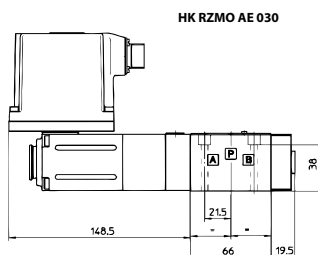

Web: <http://cat.hansa-flex.com/en/HKRZMOAE030>

Accessories:
 HK SPZ - Electrical connector for proportional valves
 HK M HK DH - Screw set for NG 6 valves type HK DH / DG4V3

HK RZMO A 030

Proportional pressure relief valve size 6

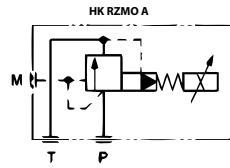

Without integrated pressure transducer (a pcb Type HK EBM AS is required for control)

Completely encapsulated solenoid coils

Response time < 60 ms

Hysteresis < 1,5%

Design: Proportional plate mounting valve, pilot-controlled

Scope of supply: with coil, without plug

Operating pressure: max. 315 bar

Volumetric flow: max. 40 l/min

Connection: ISO/Cetop 03 size 6

Identification	acts in channel	Pressure setting range min. bar	Pressure setting range max. bar	Volumetric flow min. L/min	Volumetric flow max. L/min	Weight kg
HK RZMO A 030 315	P	6	315	2,5	40,0	2,8

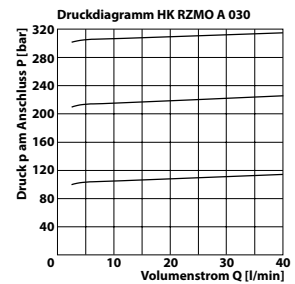
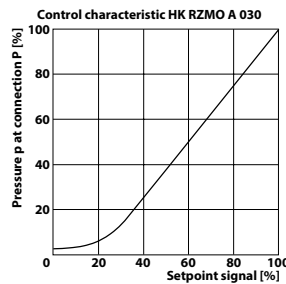
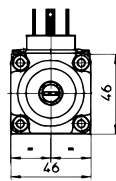
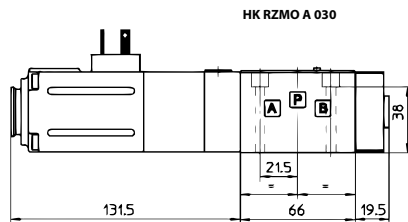

Web: <http://cat.hansa-flex.com/en/HKRZMOA030>

Accessories:

HK EBM AS - Proportional amplifier digital

HK SP DIN 43650 - Electrical plug for solenoid coil DIN 43650 / ISO 4400

HK M HK DH - Screw set for NG 6 valves type HK DH / DG4V3

HK RZMO A 010

Proportional pressure relief valve size 6

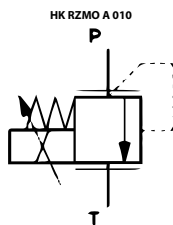

Without integrated pressure transducer (a pcb Type HK EBM AS is required for control)

Completely encapsulated solenoid coils

Response time < 70 ms

Hysteresis < 1,5%

Design: Proportional plate mounting valve, direct-controlled

Scope of supply: with coil, without plug

Operating pressure: max. 315 bar

Volumetric flow: max. 4 l/min

Connection: ISO/Cetop 03 NG6 (only P + T)

Identification	acts in channel	Pressure setting range min. bar	Pressure setting range max. bar	Volumetric flow max. L/min	Weight kg
HK RZMO A 010 210	P	4	210	4,0	1,8

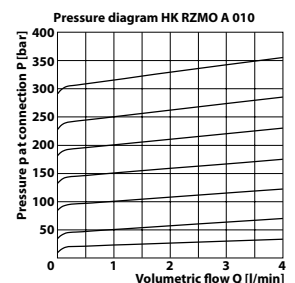
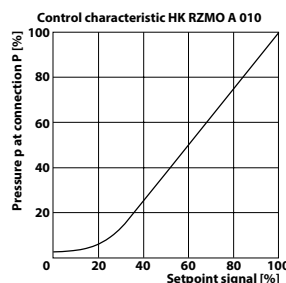
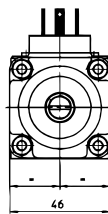
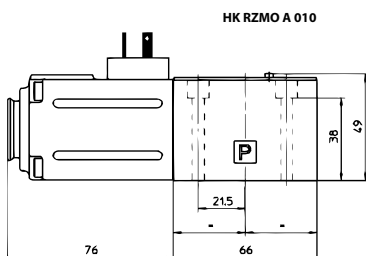

Web: <http://cat.hansa-flex.com/en/HKRZMOA010>

Accessories:

HK EBM AS - Proportional amplifier digital

HK SP DIN 43650 - Electrical plug for solenoid coil DIN 43650 / ISO 4400

HK M HK DH - Screw set for NG 6 valves type HK DH / DG4V3

HK RZGO A 033
Proportional pressure reducing valve size 6

Without integrated pressure transducer (a pcb Type HK EBM AS is required for control)

Completely encapsulated solenoid coils

Response time < 50 ms

Hysteresis < 2%

Design: Proportional plate mounting valve, pilot-controlled

Scope of supply: with coil, without plug

Operating pressure: max. 315 bar

Volumetric flow: max. 40 l/min

Connection: ISO/Cetop 03 size 6

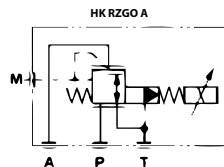

Identification	acts in channel	Pressure setting range min. bar	Pressure setting range max. bar	Volumetric flow min. L/min	Volumetric flow max. L/min	Weight kg
HK RZGO A 033 210	A	6	210	2,5	40,0	2,7

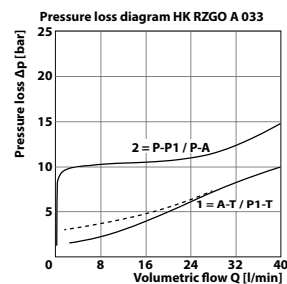
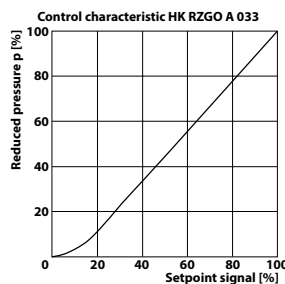
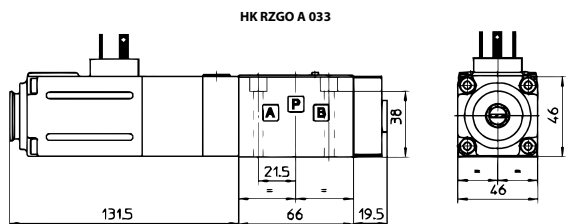

Web: <http://cat.hansa-flex.com/en/HKRZGOA033>

Accessories:

HK EBM AS - Proportional amplifier digital

HK SP DIN 43650 - Electrical plug for solenoid coil DIN 43650 / ISO 4400

HK M HK DH - Screw set for NG 6 valves type HK DH / DG4V3

HK RZGO AE 033
Proportional pressure reducing valve size 6

with integrated electronics

Response time < 50 ms

Hysteresis < 2%

Pilot signal 0-10 VDC

Design: Proportional plate mounting valve, pilot-controlled

Scope of supply: with integrated electronics, without plug

Operating pressure: max. 315 bar

Volumetric flow: max. 40 l/min

Connection: ISO/Cetop 03 size 6

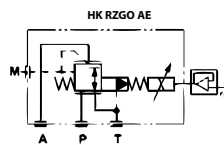

Identification	acts in channel	Pressure setting range min. bar	Pressure setting range max. bar	Volumetric flow min. L/min	Volumetric flow max. L/min	Weight kg
HK RZGO AE 033 210	A	6	210	2,5	40,0	2,7

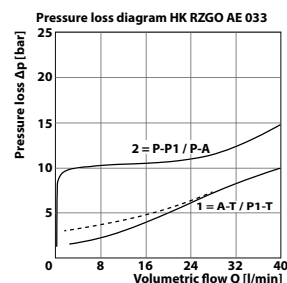
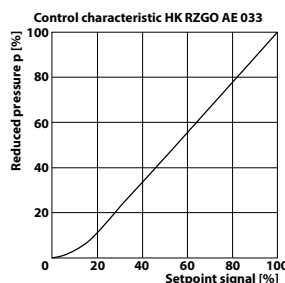
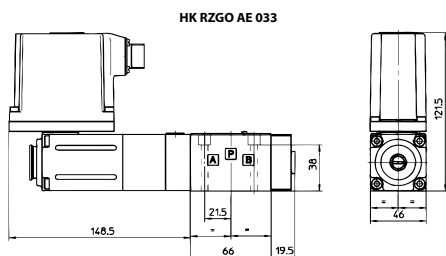

Web: <http://cat.hansa-flex.com/en/HKRZGOAE033>

Accessories:

HK SPZ - Electrical connector for proportional valves

HK M HK DH - Screw set for NG 6 valves type HK DH / DG4V3

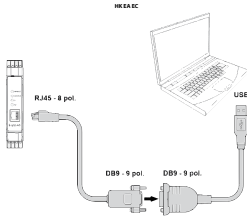
HK EA EC**Adapter cables**

For connecting the digital proportional amplifier HK EBM AS to the computer. Transfer rate up to 225 kbit/s. An external power supply is not necessary (done over a USB connection).

Use: For proportional amplifier HK EBM AS

Identification	Length m	Design	Weight kg
HK E A PS USB DB9	0,45	1x USB, 1x DB9	0,2
HK E C PS DB9 RJ45	2,50	1x DB9, 1x RJ45	0,2

Web: <http://cat.hansa-flex.com/en/HKEAEC>

Accessory for following products:

HK EBM AS - Proportional amplifier digital

Proportional amplifier digital

for single solenoid and double solenoid proportional valves without transducer

Power supply standard: +24 VDC rectified and filtered

Max. power consumption: 50 W / 100 W

Max. current supplied to solenoids: 2,7 A at 24 VDC / 3,3 A at 12 VDC

Reference input signal: ± 10 VDC / ± 20 mA

Mounting for DIN-rail 35x7,5

Design: for DIN-rail 35x7,5, 4 fast plug-in connectors, RJ45 connector for RS232 serial communication with PC software, 4 LEDs for diagnostics, Electrical protection against reverse polarity

Operating temperature max.: 60 °C

Use: for single solenoid and double solenoid proportional valves without transducer



Identification	for valve type	Weight kg
HK E BM AS PS 01H	Single solenoid for proportional valves	0,2
HK E BM AS PS 05H	Double solenoid for proportional valves	0,2

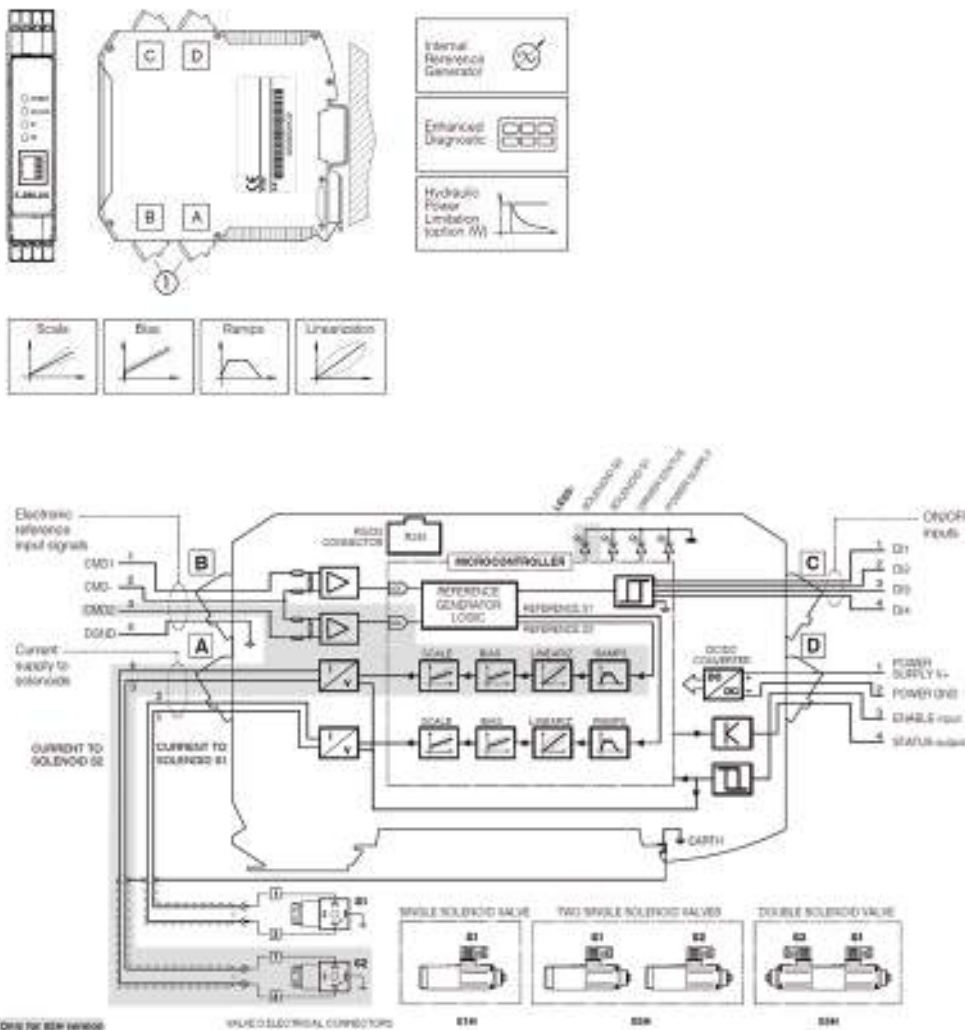

Web: <http://cat.hansa-flex.com/en/HKEBMAS>

Accessory for following products:

- HK DHZO A - Proportional solenoid-operated directional control valve size 6
- HK DKZOR A - Proportional solenoid-operated directional control valve size 10
- HK HZGO A 031 - Proportional pressure reducing valve size 6
- HK HZMO A 030 - Proportional pressure relief valve size 6
- HK KZGO A 031 - Proportional pressure reducing valve size 10
- HK RZGO A 033 - Proportional pressure reducing valve size 6
- HK RZMO A 010 - Proportional pressure relief valve size 6
- HK RZMO A 030 - Proportional pressure relief valve size 6

Additional elements:

HK EA EC - Adapter cables

HK EMI

Digital electronic driver HK EMI AS IR



for use in open and closed control loops
 Elektronik protected by sealed, vibration-damped housing
 Electronic filter on inlet and outlet
 Nominal setpoint signal preset to 0 - 10 VDC
 Settings by USB infrared adapter (please order separately)
Design: Electronic controller for proportional valves without transducer
Operating temperature max.: 60 °C
Connection: M12 - plug
Use: for single solenoid and double solenoid proportional valves without transducer

Note: corresponding M12-plug HK SP ZH 5P

Identification	Weight
HK EMI AS IR 01H M12	kg 0,5

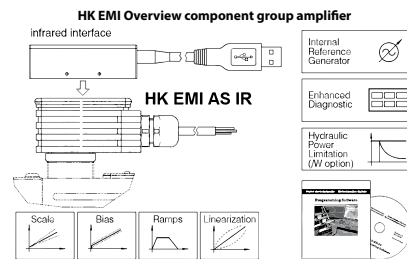
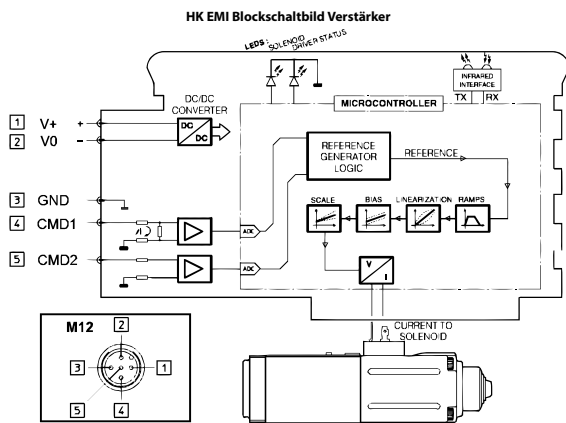

Web: <http://cat.hansa-flex.com/en/HKEMI>

Additional info: for rising and falling ramps, variable valve characteristics and dither frequency, stabilised: 24 VDC rectified and filtered (11 - 27 V), power consumption 40 W

Accessories:

- HK SPZ - Electrical connector for proportional valves
- HK EC PC IR USB - USB infrared adapter
- HK E SW - Software for ATOS proportional electronics

HK EC PC IR USB
USB infrared adapter

For computer-aided setting of the digital electronic driver HK EMI AS IR
PC connection by USB port

The adapter is plugged onto the amplifier, it is performed a direct infrared communication with the amplifier at a transmission rate of 9.6 kbit/s. An external power supply is not necessary (provided by USB connection).

Design: Adapter with USB port for chopper amplifier HK EMI

Scope of supply: Infrared adapter, USB cable 3m

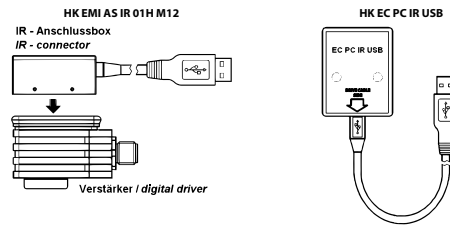

Identification	Design	Weight kg
HK EC PC IR USB	Infrared adapter with USB cable 3m	0,7

Web: <http://cat.hansa-flex.com/en/HKECPCIRUSB>

Accessories:

HK E SW - Software for ATOS proportional electronics

Additional element for following products:

HK EMI - Digital electronic driver HK EMI AS IR

HK E SW
Software for ATOS proportional electronics

Software for all parameters of ATOS proportional controls for monitoring and handling of current settings.

The graphical interface is constructed in layers, which represent different specific groups of functions and parameters.

The software automatically detects the connected valve type and adjusts the parameters displayed according to the selected access level.

System requirements: Windows XP or higher, 128MB RAM, 250MB free memory capacity, DVD-player, RS232 or USB port



Identification	Design	Weight kg
HK E SW PSN	DVD with driver, software and manual	0,2

Web: <http://cat.hansa-flex.com/en/HKESW>

Accessory for following products:

HK EMI - Digital electronic driver HK EMI AS IR

HK EC PC IR USB - USB infrared adapter

HK V7 367

3/3-way changeover valve

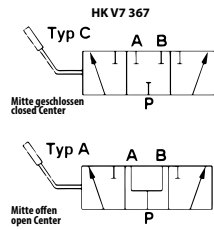

Design:
Material:

Type A - mid-position open, Type C - mid-position closed
Housing: cast iron, inner parts steel

Note: Rotary slide valves can be pressurised from all sides and are designed to have less internal leakage

Identification	Circuit diagram	Pressure max. bar	Connections	Q max. L/min	a mm	b mm	c mm	e mm	g mm	i mm	L mm	Weight kg
HK V7 367 A06		250	3/8"	40	24	73	8,5	42	62	36	110	0,92
HK V7 367 A08		250	1/2"	60	30	85	11,0	53	70	43	120	1,46
HK V7 367 A12		220	3/4"	120	32	91	11,0	54	80	47	125	1,86
HK V7 367 A16		220	1"	180	32	98	11,0	64	90	51	130	2,56
HK V7 367 C06		250	3/8"	40	24	73	8,5	42	62	36	110	0,92
HK V7 367 C08		250	1/2"	60	30	85	11,0	53	70	43	120	1,46
HK V7 367 C12		220	3/4"	120	32	91	11,0	54	80	47	125	1,86
HK V7 367 C16		220	1"	180	32	98	11,0	64	90	51	130	2,56

HK V7 367

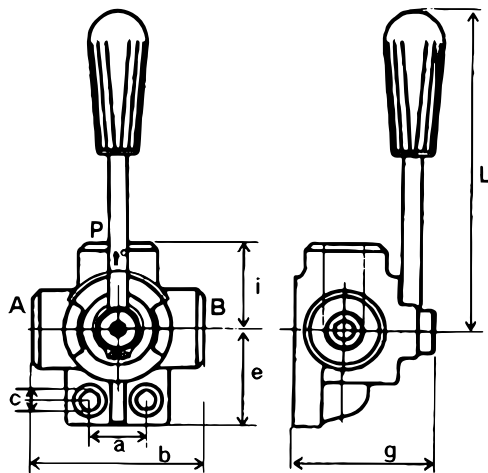

Web: <http://cat.hansa-flex.com/en/HKV7367>

HK V7 467

4/3-way changeover valve

Design: Type A - mid-position open, Type C - mid-position closed
Material: Housing: cast iron, inner parts steel

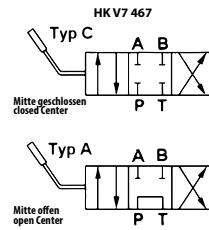

Note: Rotary slide valves can be pressurised from all sides and are designed to have less internal leakage

Identification	Circuit diagram	Pressure max. bar	Connections	Q max. L/min	a mm	b mm	c mm	e mm	g mm	i mm	L mm	Weight kg
HK V7 467 A06		250	3/8"	35	54	77	8,5	38,5	71	38,5	110	1,28
HK V7 467 A08		250	1/2"	50	68	90	8,5	45,0	80	45,0	120	1,90
HK V7 467 A12		220	3/4"	90	74	95	8,5	47,5	90	47,5	125	2,60
HK V7 467 C06		250	3/8"	35	54	77	8,5	38,5	71	38,5	110	1,28
HK V7 467 C08		250	1/2"	50	68	90	8,5	45,0	80	45,0	120	1,90
HK V7 467 C12		220	3/4"	90	74	95	8,5	47,5	90	47,5	125	2,60

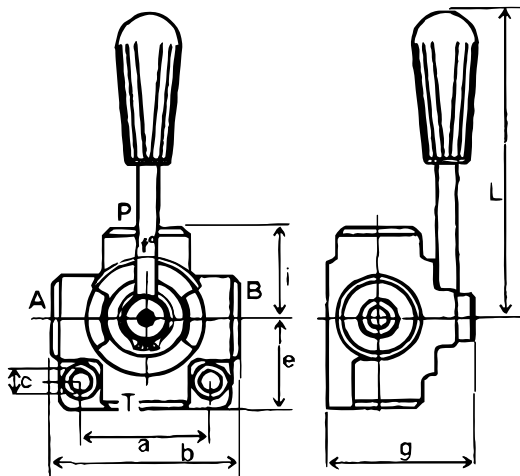
HK V7 467

Web: <http://cat.hansa-flex.com/en/HKV7467>

HK V7 667

6/3-way changeover valve

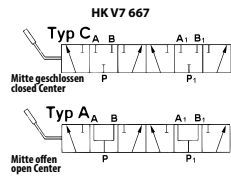

Design:
Material:

Type A - mid-position open, Type C - mid-position closed
Housing: cast iron, inner parts steel

Note: Rotary slide valves can be pressurised from all sides and are designed to have less internal leakage

Identification	Circuit diagram	Pressure max. bar	Connections	Q max. L/min	a mm	b mm	c mm	e mm	f mm	i mm	L mm	Weight kg
HK V7 667 A06		250	3/8"	40	24	73	8,5	42	124	36	110	1,7
HK V7 667 A08		250	1/2"	60	30	85	11,0	53	140	43	120	2,9
HK V7 667 A12		220	3/4"	120	32	91	11,0	54	160	47	125	3,7
HK V7 667 A16		220	1"	180	32	98	11,0	64	180	51	130	5,2
HK V7 667 C06		250	3/8"	40	24	73	8,5	42	124	36	110	1,7
HK V7 667 C08		250	1/2"	60	30	85	11,0	53	140	43	120	2,9
HK V7 667 C12		220	3/4"	120	32	91	11,0	54	160	47	125	3,7
HK V7 667 C16		220	1"	180	32	98	11,0	64	180	51	130	5,2

HK V7 667

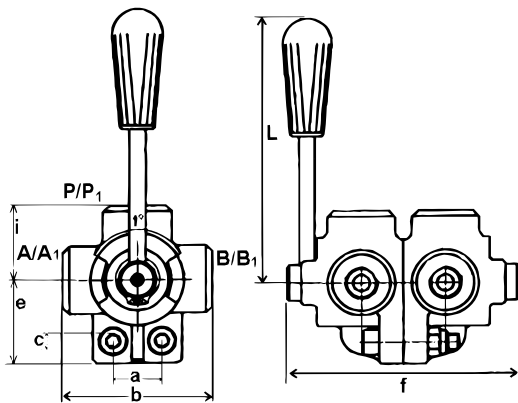

Web: <http://cat.hansa-flex.com/en/HKV7667>

HK V7 867

8/3-way changeover valve

Design: Type A - mid-position open, Type C - mid-position closed
Material: Housing: cast iron, inner parts steel

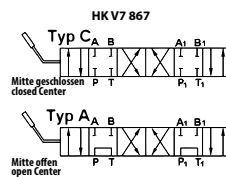

Note: Rotary slide valves can be pressurised from all sides and are designed to have less internal leakage

Identification	Circuit diagram	Pressure max. bar	Connections	Q max. L/min	a mm	b mm	c mm	e mm	f mm	i mm	L mm	Weight kg
HK V7 867 A06		250	3/8"	35	54	77	8,5	38,5	142	38,5	110	2,5
HK V7 867 A08		250	1/2"	50	68	90	8,5	45,0	160	45,0	120	3,8
HK V7 867 A12		220	3/4"	90	74	95	8,5	47,5	180	47,5	125	5,2
HK V7 867 C06		250	3/8"	35	54	77	8,5	38,5	142	38,5	110	2,5
HK V7 867 C08		250	1/2"	50	68	90	8,5	45,0	160	45,0	120	3,8
HK V7 867 C12		220	3/4"	90	74	95	8,5	47,5	180	47,5	125	5,2

HK V7 867

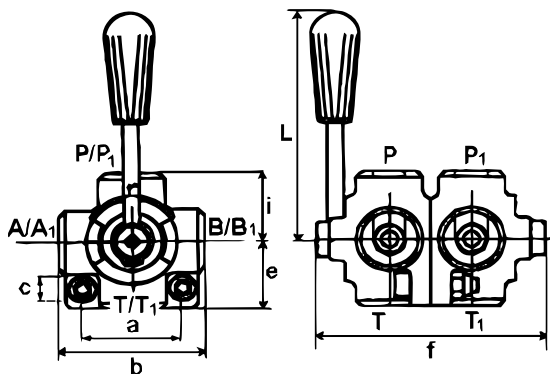

Web: <http://cat.hansa-flex.com/en/HKV7867>

HK DFE 3

3/2-way directional solenoid valve for pipeline installation

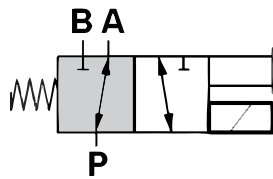

These directional control valves are for switching over the oil flow
Solenoid coil IP66

Design: with manual emergency operation, NBR seals

Scope of supply: with coil, without plug

Operating pressure: max. 315 bar with leak oil port / max. 200 bar without leak oil port

Ordering information: Other control voltages available on request

Identification	Q max. L/min	Control voltage VDC	A mm	Connection A-B-P	Leak oil connection	B mm	C mm	D mm	Design	Weight kg
HK DFE 052 3AW 12DC	60	12	166,0	G 3/8"	-	42,0	80,0	68,0	without oil return port	1,6
HK DFE 052 3AW 24DC	60	24	166,0	G 3/8"	-	42,0	80,0	68,0	without oil return port	1,6
HK DFE 052 3AY 12DC	60	12	166,0	G 3/8"	G 1/4"	42,0	80,0	68,0	with side-mounted leak oil port	1,6
HK DFE 052 3AY 24DC	60	24	166,0	G 3/8"	G 1/4"	42,0	80,0	68,0	with side-mounted leak oil port	1,6
HK DFE 100 3AW 12DC	90	12	213,5	G 1/2"	-	46,5	121,0	74,0	without oil return port	2,9
HK DFE 100 3AW 24DC	90	24	213,5	G 1/2"	-	46,5	121,0	74,0	without oil return port	2,9
HK DFE 100 3AY 12DC	90	12	213,5	G 1/2"	G 1/4"	46,5	121,0	74,0	with side-mounted leak oil port	2,9
HK DFE 100 3AY 24DC	90	24	213,5	G 1/2"	G 1/4"	46,5	121,0	74,0	with side-mounted leak oil port	2,9
HK DFE 200 3AW 12DC	140	12	226,0	G 3/4"	-	65,0	107,0	85,0	without oil return port	4,2
HK DFE 200 3AW 24DC	140	24	226,0	G 3/4"	-	65,0	107,0	85,0	without oil return port	4,2
HK DFE 200 3AY 12DC	140	12	226,0	G 3/4"	G 1/4"	65,0	107,0	85,0	with side-mounted leak oil port	4,2
HK DFE 200 3AY 24DC	140	24	226,0	G 3/4"	G 1/4"	65,0	107,0	85,0	with side-mounted leak oil port	4,2

Qmax - max intake volumetric flow

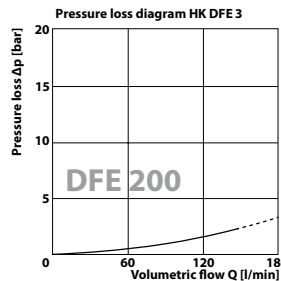
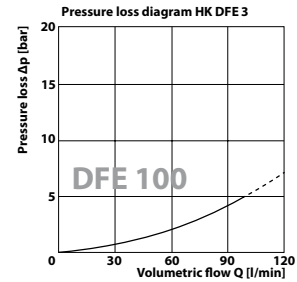
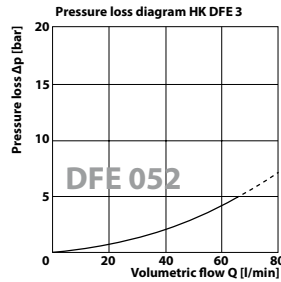
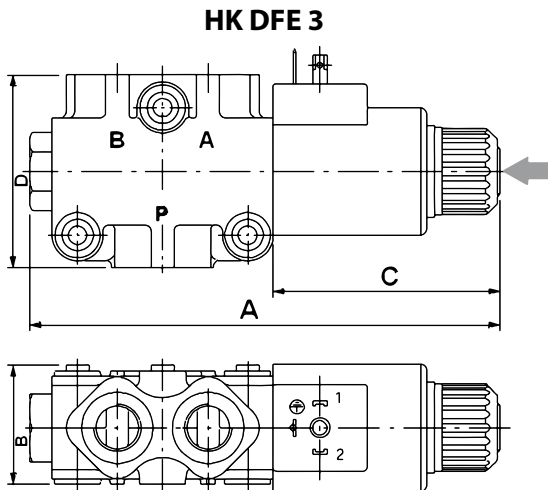

Web: <http://cat.hansa-flex.com/en/HKDFE3>

Spare parts:

HK SP DFE - Coil for solenoid-operated directional control valve HK DFE

Accessories:

HK SP DIN 43650 - Electrical plug for solenoid coil DIN 43650 / ISO 4400

6/2-way directional solenoid valve for pipeline installation

These directional control valves (valve switches) can be used optionally for supplying two hydraulic circuits.

Solenoid coil IP66

Design: with manual emergency operation, NBR seals

Scope of supply: with coil, without plug

Operating pressure: max. 315 bar with leak oil port / max. 200 bar without leak oil port

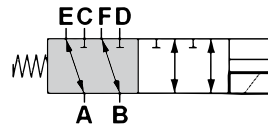

Ordering information: Other control voltages available on request

Identification	Q max. L/min	Control voltage VDC	A mm	Connection A - F Leak oil connection	B mm	C mm	D mm	Design	Weight kg	
HK DFE 052 6AW 12DC	60	12 VDC	181,0	G 3/8"	-	76,0	80,0	55,0	without oil return port	1,9
HK DFE 052 6AW 24DC	60	24 VDC	181,0	G 3/8"	-	76,0	80,0	55,0	without oil return port	1,9
HK DFE 052 6AY 12DC	60	12 VDC	181,0	G 3/8"	G 1/4"	76,0	80,0	55,0	with side-mounted leak oil port	1,9
HK DFE 052 6AY 24DC	60	24 VDC	181,0	G 3/8"	G 1/4"	76,0	80,0	55,0	with side-mounted leak oil port	1,9
HK DFE 100 6AW 12DC	90	12 VDC	241,0	G 1/2"	-	89,0	121,0	62,0	without oil return port	3,7
HK DFE 100 6AW 24DC	90	24 VDC	241,0	G 1/2"	-	89,0	121,0	62,0	without oil return port	3,7
HK DFE 100 6AY 12DC	90	12 VDC	241,0	G 1/2"	G 1/4"	89,0	121,0	62,0	with side-mounted leak oil port	3,7
HK DFE 100 6AY 24DC	90	24 VDC	241,0	G 1/2"	G 1/4"	89,0	121,0	62,0	with side-mounted leak oil port	3,7
HK DFE 200 6AW 12DC	140	12 VDC	262,0	G 3/4"	-	105,0	107,0	75,0	without oil return port	5,3
HK DFE 200 6AW 24DC	140	24 VDC	262,0	G 3/4"	-	105,0	107,0	75,0	without oil return port	5,3
HK DFE 200 6AY 12DC	140	12 VDC	262,0	G 3/4"	G 1/4"	105,0	107,0	75,0	with side-mounted leak oil port	5,3
HK DFE 200 6AY 24DC	140	24 VDC	262,0	G 3/4"	G 1/4"	105,0	107,0	75,0	with side-mounted leak oil port	5,3

Qmax - max intake volumetric flow

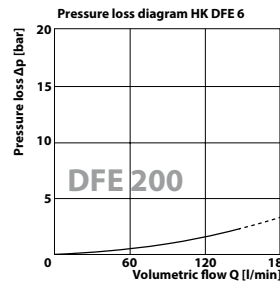
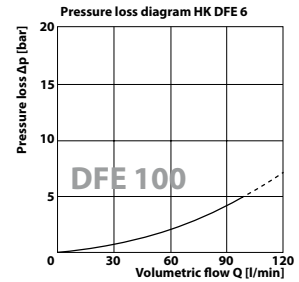
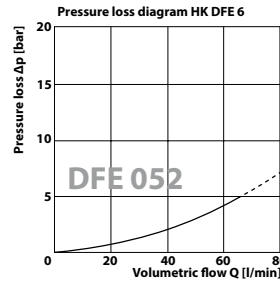
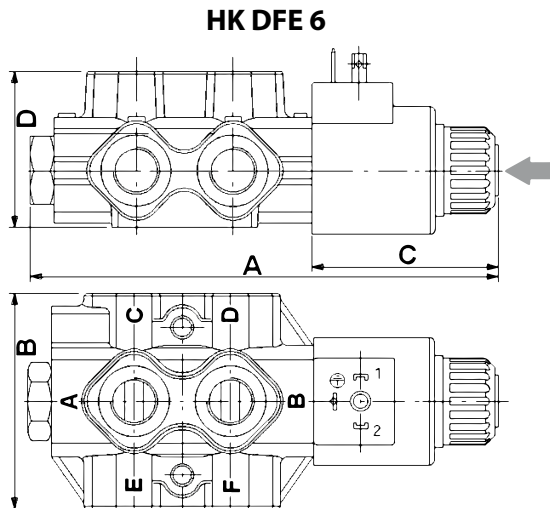

Web: <http://cat.hansa-flex.com/en/HKDFE6>

Spare parts:

HK SP DFE - Coil for solenoid-operated directional control valve HK DFE

Accessories:

HK SP DIN 43650 - Electrical plug for solenoid coil DIN 43650 / ISO 4400

HK BM40

Hand-operated directional control valve BM 40



compact design
 Integrated non-return valve and pressure relief valve 90-220bar (valve must be set)
 spool with control notches for sensitive operation
 Up to 7 sections possible.

Design: Monobloc valve for pipeline installation without hand lever (please order separately)
Scope of supply: P, A, B: max. 220bar / T: max. 80bar
Operating pressure: P, A, B: max. 220bar / T: max. 80bar
Volumetric flow: max. 40 l/min (note characteristic curves)
Connection: P + T = G 3/8"; P2 + T2 = G 1/2"; A + B = G 3/8"

Ordering information: Please order hand lever separately - 1 lever per section!
 The valves are available in the stated basic version. For other possible configurations for actuators and piston types see graphic.

- Example configuration HKBM40A1L12:
 - Valve type HKBM40
 - Section 1 with piston type A and actuator 1
 - Section 2 with piston type L and actuator 12

Identification	Circuit diagram	I mm	L mm	Design	Weight kg
HK BM40 A1		55	90	1 Section (A1)	2,5
HK BM40 K16		55	90	1 Section (K16)	2,5
HK BM40 L12		55	90	1 Section (L12)	2,5
HK BM40 A1X2		90	125	2 Section (2xA1)	3,7
HK BM40 A1 K16		90	125	2 Section (1xA1; 1xK16)	3,7
HK BM40 A1 L12		90	125	2 Section (1xA1; 1xL12)	3,7
HK BM40 A1X3		125	160	3 Section (3xA1)	5,0
HK BM40 A1X2 K16		125	160	3 Section (2xA1; 1xK16)	5,0
HK BM40 A1X2 L12		125	160	3 Section (2xA1; 1xL12)	5,0
HK BM40 A1X4		160	195	4 Section (4xA1)	6,2
HK BM40 A1X3 K16		160	195	4 Section (3xA1; 1xK16)	6,2
HK BM40 A1X3 L12		160	195	4 Section (3xA1; 1xL12)	5,0
HK BM40 A1X5		195	230	5 Section (5xA1)	7,4
HK BM40 A1X4 K16		195	230	5 Section (4xA1; 1xK16)	7,4
HK BM40 A1X4 L12		195	230	5 Section (4xA1; 1xL12)	7,4
HK BM40 A1X6		230	265	6 Section (6xA1)	8,6
HK BM40 A1X5 K16		230	265	6 Section (5xA1; 1xK16)	8,6
HK BM40 A1X5 L12		230	265	6 Section (5xA1; 1xL12)	8,6
HK BM40 A1X7		265	300	7 Section (7xA1)	9,8



(Continued)

HK BM40

Hand-operated directional control valve BM 40

Identification	Circuit diagram	l mm	L mm	Design	Weight kg
HK BM40 A1X6 K16		265	300	7 Section (6x A1; 1x K16)	9,8
HK BM40 A1X6 L12		265	300	7 Section (6x A1; 1x L12)	9,8

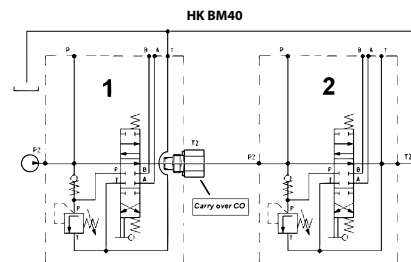
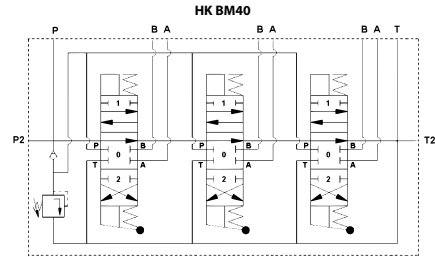
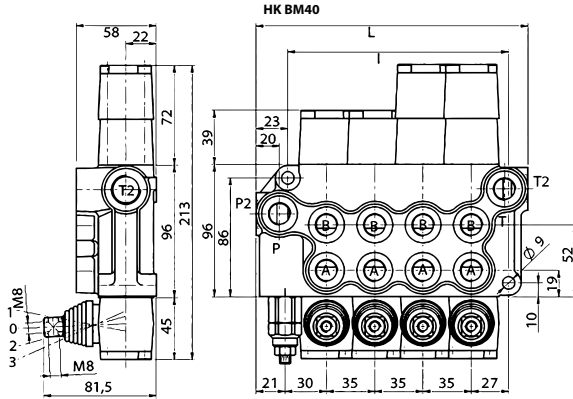

Pistons, actuators, accessories for HK BM 40

Piston types (1)	HK BM40	Actuators (2)	HK BM40	Accessories (3)	HK BM40
A		1		CO	
B		2		MS0	
D		3		MS1	
E		4		MS2	
F		5			
K		6			
L		7			
M		8			
		9			
		10			
		11			
		12			
		13			
		14			
		15			
		16			

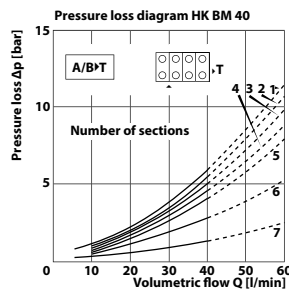
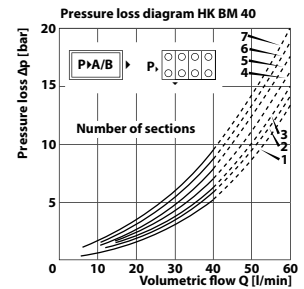
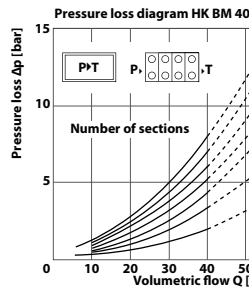

Web: <http://cat.hansa-flex.com/en/HKBM40>

Spare parts:

- HK BM KOL - Piston for hand-operated directional control valve BM
- HK BM BET - Actuation for hand-operated directional control valve BM

Accessories:

- HK BM HEB - Hand lever & accessories for hand-operated directl. control valve BM
- HK BM CO - Pressure transmission for hand-operated directional control valve BM
- HK BM MS - Microswitch for hand-operated directional control valve BM

HK BM70

Hand-operated directional control valve BM 70



compact design
 Integrated non-return valve and pressure relief valve 90-220bar (valve must be set)
 spool with control notches for sensitive operation
 Up to 6 sections possible.

Design: Monobloc valve for pipeline installation
Scope of supply: without hand lever (please order separately)
Operating pressure: P, A, B: max. 220bar / T: max. 80bar
Volumetric flow: max. 70 l/min (note characteristic curves)
Connection: P + T = G 1/2"; P2 + T2 = G 3/4"; A + B = G 1/2"

Ordering information: Please order hand lever separately - 1 lever per section!
 The valves are available in the stated basic version. For other possible configurations for actuators and piston types see graphic.

- Example configuration HKBM70A1L12:
 - Valve type HKBM70
 - Section 1 with piston type A and actuator 1
 - Section 2 with piston type L and actuator 12

Identification	Circuit diagram	I mm	L mm	Design	Weight kg
HK BM70 A1		66	117	1 Section (A1)	4,6
HK BM70 L12		66	117	1 Section (L12)	4,6
HK BM70 A1X2		106	157	2 Section (2xA1)	7,0
HK BM70 A1 L12		106	157	2 Section (1xA1; 1xL12)	7,0
HK BM70 A1X3		145	197	3 Section (3xA1)	9,2
HK BM70 A1X2 L12		145	197	3 Section (2xA1; 1xL12)	9,2
HK BM70 A1X4		186	237	4 Section (4xA1)	11,5
HK BM70 A1X5		226	277	5 Section (5xA1)	13,7
HK BM70 A1X6		266	317	6 Section (6xA1)	16,0

(Continued)

HK BM70

Hand-operated directional control valve BM 70

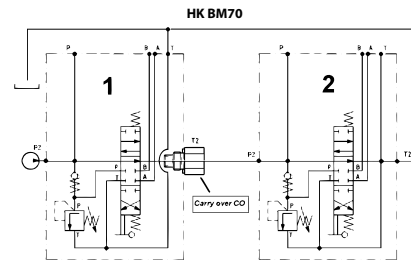
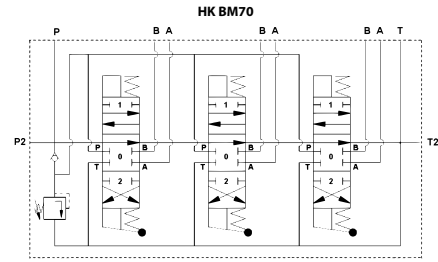
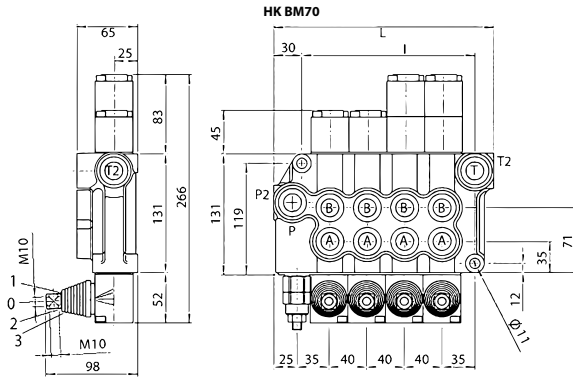

Pistons, actuators, accessories for HK BM 70

Piston types (1)		Actuators (2)		Accessories (3)	
	HK BM70		HK BM70		HK BM70
A		1		CO	
B		2		MS0	
C		3		MS1	
D		4		MS2	
F		5			
L		6			
		7			
		8			
		9			
		10			
		11			
		12			

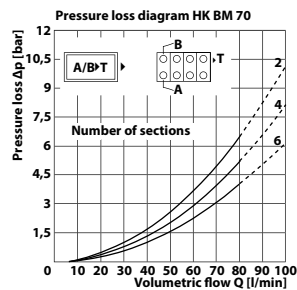
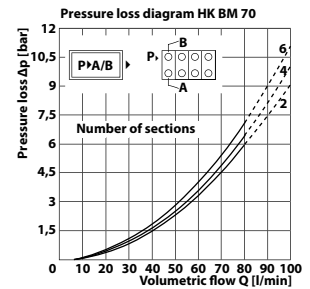
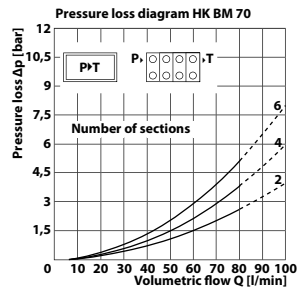

Web: <http://cat.hansa-flex.com/en/HKBM70>

Spare parts:

- HK BM KOL - Piston for hand-operated directional control valve BM
- HK BM BET - Actuation for hand-operated directional control valve BM

Accessories:

- HK BM HEB - Hand lever & accessories for hand-operated directl. control valve BM
- HK BM C0 - Pressure transmission for hand-operated directional control valve BM
- HK BM MS - Microswitch for hand-operated directional control valve BM

HK BM70 AUTO

Hand-operated directional control valve BM 70 with high-speed function



double-action with high-speed function
compact design

Design: Monobloc valve for pipeline installation
Scope of supply: without hand lever (please order separately)
Operating pressure: P, A, B: max. 220bar / T: max. 80bar
Volumetric flow: max. 70 l/min
Connection: P + T = G 1/2"; P2 = G 3/4"; A + B = G 1/2"
Use: especially for use in wood splitters

Note: Log-splitter valve with pressure-dependent switching of splitting speed for maximum splitting force. Function retract / lift with latching (mechanical end switch). With the version with the kick-out function, the valve automatically switches into the mid-setting (stop position) when it reaches the end stop while the cylinder is retracting.

Ordering information: Please order hand lever separately - 1 lever per section!

Identification	Design	Weight kg
HK BM70 S6 AUTO	1 Section (S6)	4,8
HK BM70 S2 KOB AUTO	1 Section (S2KOB) / Kick-Out	4,9

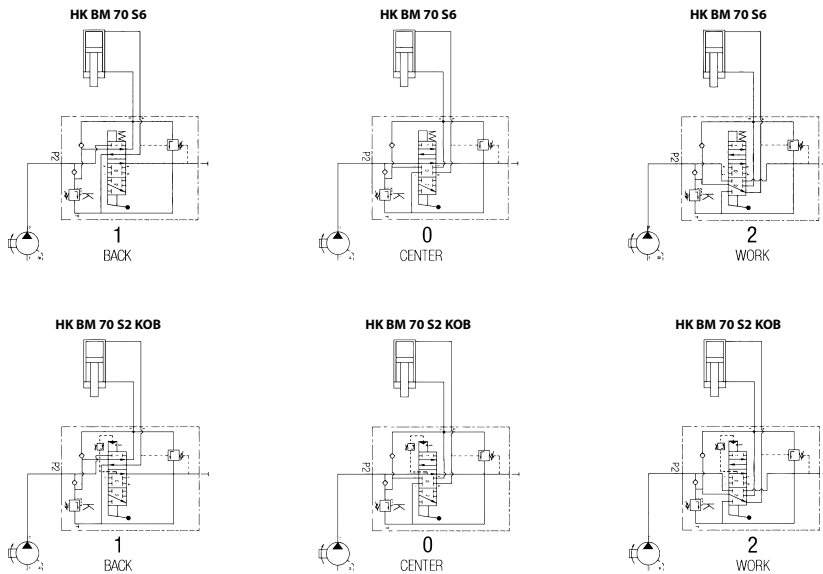
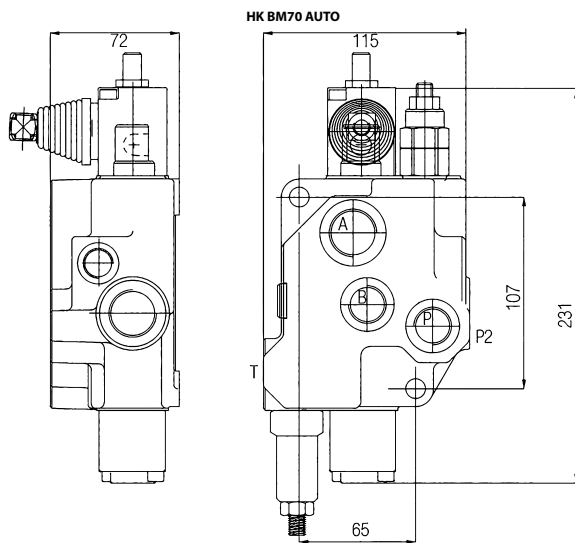

Web: <http://cat.hansa-flex.com/en/HKBM70AUTO>

Accessories:
 HK BM HEB - Hand lever & accessories for hand-operated directl. control valve BM

HK BM150

Hand-operated directional control valve BM 150

- compact design
- Integrated non-return valve and pressure relief valve 90-220bar (valve must be set)
- spool with control notches for sensitive operation
- only possible with 1 section
- Design:** Monobloc valve for pipeline installation
- Scope of supply:** without hand lever (please order separately)
- Operating pressure:** P, A, B: max. 220bar / T: max. 80bar
- Volumetric flow:** max. 150 l/min (note characteristic curves)
- Connection:** P + T = G 3/4"; P2 + T2 = G 1"; A + B = G 3/4"

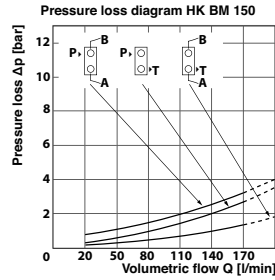

Ordering information: Please order hand lever separately - 1 lever per section!
 The valves are available in the stated basic version. For other possible configurations for actuators and piston types see graphic.
 Example configuration HKBM150A1:
 - Valve type HKBM150
 - Section 1 with piston type A and actuator 1

Identification	Circuit diagram	Design	Weight kg
HK BM150 A1		1 Section (A1)	8,2

Pistons, actuators, accessories for HK BM 150

Piston types (1)	HK BM150	Actuators (2)	HK BM150	Accessories (3)	HK BM150
A		1			•
B		2			•
C		3			•
D		4			•
		6			•
		8			•
		9			•
		10			•

Druckweiterleitung/Carry over

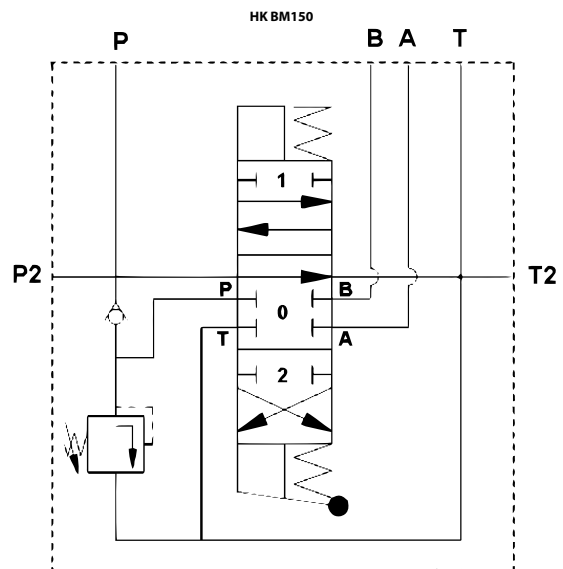
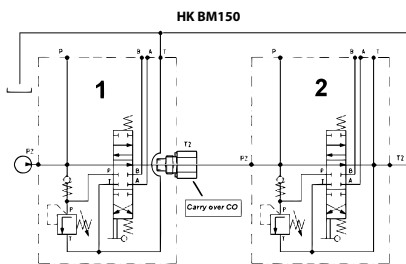
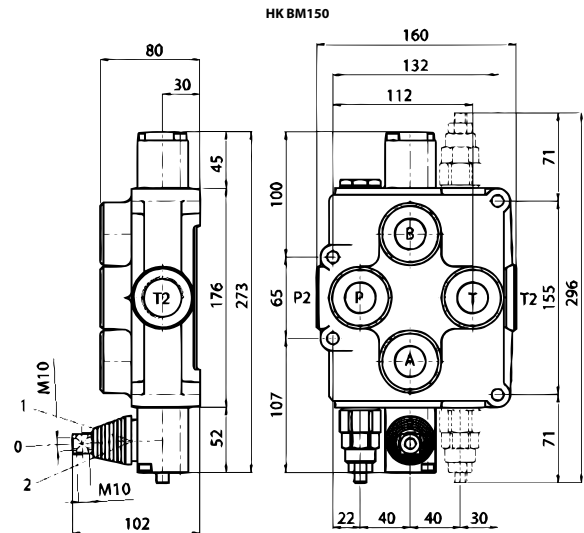

Web: <http://cat.hansa-flex.com/en/HKBM150>

- Spare parts:**
 HK BM KOL - Piston for hand-operated directional control valve BM
 HK BM BET - Actuation for hand-operated directional control valve BM

- Accessories:**
 HK BM HEB - Hand lever & accessories for hand-operated directl. control valve BM
 HK BM CO - Pressure transmission for hand-operated directional control valve BM

HK BM HEB

Hand lever & accessories for hand-operated directl. control valve BM

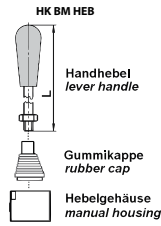

Scope of supply: with counter nut
Material: Steel

Identification	for valve type	L mm	Design	Weight kg
HK BM40 DBAL	HK BM40	180	Hand lever	0,20
HK BM70 DBAL	HK BM70/HK BM150	210	Hand lever	0,20
HK BM40 DBSF	HK BM40		Rubber cap	0,05
HK BM70 DBSF	HK BM70/HK BM150		Rubber cap	0,05
HK BM40 DBLE	HK BM40		Lever housing	0,20
HK BM70 DBLE	HK BM70/HK BM150		Lever housing	0,20

Web: <http://cat.hansa-flex.com/en/HKBMHEB>

Accessory for following products:

HK BM40 - Hand-operated directional control valve BM 40

HK BM70 - Hand-operated directional control valve BM 70

HK BM70 AUTO - Hand-operated directional control valve BM 70 with high-speed function

HK BM150 - Hand-operated directional control valve BM 150

HK BM BET

Actuation for hand-operated directional control valve BM



Scope of supply: incl. set of screws
Use: for converting the actuation mode of manual control valve HK BM

Identification	Circuit diagram	for valve type	Weight kg
HK BM40 1		HK BM40	0,10
HK BM40 2		HK BM40	0,10
HK BM40 3		HK BM40	0,10
HK BM40 4		HK BM40	0,10
HK BM40 5		HK BM40	0,10
HK BM40 6		HK BM40	0,10
HK BM40 7		HK BM40	0,10
HK BM40 8		HK BM40	0,10
HK BM40 9		HK BM40	0,10
HK BM40 10		HK BM40	0,10

(Continued)

HK BM BET

Actuation for hand-operated directional control valve BM

Identification	Circuit diagram	for valve type	Weight kg
HK BM40 11		HK BM40	0,10
HK BM40 13		HK BM40	0,10
HK BM40 16		HK BM40	0,10
HK BM70 1		HK BM70	0,15
HK BM70 2		HK BM70	0,15
HK BM70 3		HK BM70	0,15
HK BM70 4		HK BM70	0,15
HK BM70 5		HK BM70	0,15
HK BM70 6		HK BM70	0,15
HK BM70 7		HK BM70	0,15
HK BM70 8		HK BM70	0,15
HK BM70 9		HK BM70	0,15
HK BM70 10		HK BM70	0,15
HK BM70 11		HK BM70	0,15
HK BM70 12		HK BM70	0,15
HK BM70 13		HK BM70	0,15
HK BM150 1		HK BM150	0,20
HK BM150 2		HK BM150	0,20
HK BM150 3		HK BM150	0,20
HK BM150 4		HK BM150	0,20
HK BM150 6		HK BM150	0,20
HK BM150 8		HK BM150	0,20
HK BM150 9		HK BM150	0,20
HK BM150 10		HK BM150	0,20

Web: <http://cat.hansa-flex.com/en/HKBM BET>

Accessory for following products:

HK BM40 - Hand-operated directional control valve BM 40

HK BM70 - Hand-operated directional control valve BM 70

HK BM150 - Hand-operated directional control valve BM 150

HK BM KOL

Piston for hand-operated directional control valve BM



Use: for converting the switch function of manual control valve HK BM

1

Identification	Circuit diagram	for valve type	Weight kg
HK BM40 A		HK BM40	0,20
HK BM40 B		HK BM40	0,20
HK BM40 D		HK BM40	0,20
HK BM40 E		HK BM40	0,20
HK BM40 F		HK BM40	0,20
HK BM40 K		HK BM40	0,20
HK BM40 M		HK BM40	0,20
HK BM70 A		HK BM70	0,30
HK BM70 B		HK BM70	0,30
HK BM70 C		HK BM70	0,30
HK BM70 D		HK BM70	0,30
HK BM70 F		HK BM70	0,30
HK BM70 L		HK BM70	0,30
HK BM150 A		HK BM150	0,35
HK BM150 B		HK BM150	0,35
HK BM150 C		HK BM150	0,35
HK BM150 D		HK BM150	0,35

Web: <http://cat.hansa-flex.com/en/HKBMKOL>

Accessory for following products:

- HK BM40 - Hand-operated directional control valve BM 40
- HK BM70 - Hand-operated directional control valve BM 70
- HK BM150 - Hand-operated directional control valve BM 150

HK BM C0

Pressure transmission for hand-operated directional control valve BM

The pressure transmission is suitable for linking monobloc valves type HK BM together. In this situation, the pressure transmission on valve 1 is screwed into the oil port T2. The return flow to the tank on valve 1 must be connected to the top port T1.

If valve 1 is not actuated, another function can be controlled at full pressure and volume flow using valve 2. If valve 1 is actuated, then no pressure is available at valve 2.

Scope of supply: with O-ring

Material: Steel

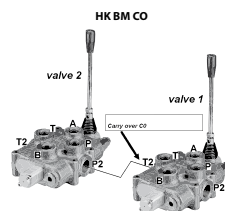

Identification	for valve type	Weight kg
HK BM40 C0	HK BM40	0,10
HK BM70 C0	HK BM70	0,10
HK BM150 C0	HK BM150	0,15

Web: <http://cat.hansa-flex.com/en/HKBMC0>

Accessory for following products:

HK BM40 - Hand-operated directional control valve BM 40

HK BM70 - Hand-operated directional control valve BM 70

HK BM150 - Hand-operated directional control valve BM 150

HK BM MS

Microswitch for hand-operated directional control valve BM

Scope of supply: incl. set of screws

Use: for electrical sensing of the switch position

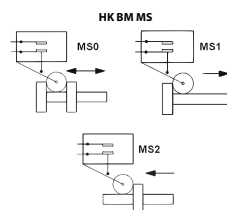

Identification	for valve type	Design	Weight kg
HK BM40 MS0	HK BM40	Switch contact in valve position 1 and 2	0,10
HK BM40 MS1	HK BM40	Switch contact in valve position 1	0,10
HK BM40 MS2	HK BM40	Switch contact in valve position 2	0,10
HK BM70 MS0	HK BM70	Switch contact in valve position 1 and 2	0,10
HK BM70 MS1	HK BM70	Switch contact in valve position 1	0,10
HK BM70 MS2	HK BM70	Switch contact in valve position 2	0,10
HK BM40 DBM	HK BM40	Replacement button	0,10

Web: <http://cat.hansa-flex.com/en/HKBMS>

Accessory for following products:

HK BM40 - Hand-operated directional control valve BM 40

HK BM70 - Hand-operated directional control valve BM 70

HK FT 290

Pressure gauge shut-off valve FT290

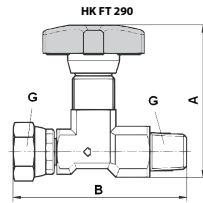

Isolation and throttle non-return valve for hydraulic pressure gauge

Design: straight
Material: Steel with plastic wheel
Operating pressure: max. 400 bar

Identification	A mm	B mm	G	Weight kg
HK FT 290-14	57	62	1/4" AG/IG	0,13
HK FT 290-12	75	82	1/2" AG/IG	0,40

Web: <http://cat.hansa-flex.com/en/HKFT290>

HK FT 291

Pressure gauge shut-off valve FT291

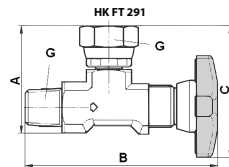

Isolation and throttle non-return valve for hydraulic pressure gauge

Design: rectangular
Material: Steel with plastic wheel
Operating pressure: max. 400 bar

Identification	A mm	B mm	C mm	G	Weight kg
HK FT 291-14	39	69	48	1/4" AG/IG	0,11

Web: <http://cat.hansa-flex.com/en/HKFT291>

Coil for HKDH solenoid-operated valve

Scope of supply: with O-ring

Corresponding connectors: HKSP664, HKSP666, HKSP667, HKSP668, HKSP669 (rectifier plug)



Note: As far as AC coils are concerned, power input is considerably higher in the take-up phase than in the stopping phase. These must therefore never be operated without a magnet core since there is a danger of overheating and the coil can burn through.

A similar effect occurs if valves with AC magnets are operated with extremely high pulse frequencies (On / Off). In such cases the coils, which are often in the vicinity of the high power input, can also overheat. For such applications the use of RC coils with rectifier plugs is recommended.

With DC coils extremely high power spikes can occur during powering down. We therefore recommend the use of plugs with protective circuits when using such coils.

Tightening torque for attaching nuts of the solenoid coils: 3Nm

Please use rectifier plug HKSP669 for solenoid coils type RC.

Ordering information: Other types of coil on request

Identification	Nominal voltage +/- 10 %	for valve type	Average power consumption		Average current consumption		Weight kg
			W		A		
HK SP COE 12DC	12 VDC	HK DHE DC	30		2,80		0,30
HK SP COE 24DC	24 VDC	HK DHE DC	30		1,40		0,30
HK SP COE 28DC	28 VDC	HK DHE DC	30		1,24		0,30
HK SP COE 110AC	110 VAC	HK DHE AC	30		0,50		0,30
HK SP COE 230AC	230 VAC	HK DHE AC	30		0,25		0,30
HK SP COE 230RC	230 VRC	HK DHE DC	58		0,25		0,30

Web: <http://cat.hansa-flex.com/en/HKSPCO>

Spare part for following products:

HK DHE X 00 DC - Solenoid-operated directional control valve size 6 without coil

HK DHE X 00 AC - Solenoid-operated directional control valve size 6 without coil

Accessories:

HK SP DIN 43650 - Electrical plug for solenoid coil DIN 43650 / ISO 4400

HK UEB MUT - Cap nut for solenoid-operated directional control valve

HK SP 41C**Coil for HK41C solenoid-operated valve**

Scope of supply: with O-ring
Corresponding connectors: HKSP664, HKSP666, HKSP667, HKSP668

Note: As far as AC coils are concerned, power input is considerably higher in the take-up phase than in the stopping phase. These must therefore never be operated without a magnet core since there is a danger of overheating and the coil can burn through.
 A similar effect occurs if valves with AC magnets are operated with extremely high pulse frequencies (On / Off). In such cases the coils, which are often in the vicinity of the high power input, can also overheat. For such applications the use of RC coils with rectifier plugs is recommended.
 With DC coils extremely high power spikes can occur during powering down. We therefore recommend the use of plugs with protective circuits when using such coils.

Ordering information: Other types of coil on request

Identification	Nominal voltage +/- 10 %	Average power consumption		Average current consumption		Weight kg
		W	A	W	A	
HK SP 12V 41C	12 VDC	32	2,72	0,35		
HK SP 24V 41C	24 VDC	31	1,29	0,35		
HK SP 205V 41C	205 VDC	31	0,44	0,35		
HK SP 115V 41C	115 VAC	80	0,65	0,50		
HK SP 230V 41C	230 VAC	80	0,33	0,50		

Web: <http://cat.hansa-flex.com/en/HKSP41C>

Spare part for following products:

HK 41 C1 (7/G/Q/R) - Solenoid-operated directional control valve NG6

Accessories:

HK SP DIN 43650 - Electrical plug for solenoid coil DIN 43650 / ISO 4400

HK UEB MUT - Cap nut for solenoid-operated directional control valve

HK SP DG4V3**Coil for HK DG4V3 solenoid-operated valve**

Corresponding connectors: HKSP664, HKSP666, HKSP667, HKSP668, HKSP669 (rectifier plug)

Note: As far as AC coils are concerned, power input is considerably higher in the take-up phase than in the stopping phase. These must therefore never be operated without a magnet core since there is a danger of overheating and the coil can burn through.
 A similar effect occurs if valves with AC magnets are operated with extremely high pulse frequencies (On / Off). In such cases the coils, which are often in the vicinity of the high power input, can also overheat. For such applications the use of RC coils with rectifier plugs is recommended.
 With DC coils extremely high power spikes can occur during powering down. We therefore recommend the use of plugs with protective circuits when using such coils.
 Tightening torque for attaching nuts of the solenoid coils: 3Nm

Ordering information: Other types of coil on request

Identification	Nominal voltage +/- 10 %	Average power consumption		Weight kg
		W	A	
HK DG4V3 G 12VDC	12 VDC	30	0,55	
HK DG4V3 H 24VDC	24 VDC	30	0,55	
HK DG4V3 A 110VAC	110 VAC	7	0,55	
HK DG4V3 EP 230VAC	230 VAC	7	0,55	

Web: <http://cat.hansa-flex.com/en/HKSPDG4V3>

Spare part for following products:

HK DG4V3 - Solenoid-operated directional control valve NG6

Accessories:

HK SP DIN 43650 - Electrical plug for solenoid coil DIN 43650 / ISO 4400

Coil for solenoid-operated directional control valve HK DKE

Scope of supply: with O-ring

Corresponding connectors: HKSP664, HKSP666, HKSP667, HKSP668



Note: As far as AC coils are concerned, power input is considerably higher in the take-up phase than in the stopping phase.

These must therefore never be operated without a magnet core since there is a danger of overheating and the coil can burn through.

A similar effect occurs if valves with AC magnets are operated with extremely high pulse frequencies (On / Off). In such cases the coils, which are often in the vicinity of the high power input, can also overheat. For such applications the use of RC coils with rectifier plugs is recommended.

With DC coils extremely high power spikes can occur during powering down. We therefore recommend the use of plugs with protective circuits when using such coils.

Tightening torque for attaching nuts of the solenoid coils: 3Nm

Ordering information: Other types of coil on request

Identification	Nominal voltage +/- 10 %	for valve type	Average power consumption	
			W	Weight kg
HK SP CAE 12DC	12 VDC	HK DKE DC	36	1,10
HK SP CAE 24DC	24 VDC	HK DKE DC	36	1,10
HK SP CAE 230RC	230 VRC	HK DKE DC	36	0,52
HK SP CAE 110AC	110 VAC		95	0,40
HK SP CAE 230AC	230 VAC		95	0,40
HK SP CAE 220DC	230 VRC	HK DKE DC	36	0,40

Web: <http://cat.hansa-flex.com/en/HKSPCAE>

Spare part for following products:

HK DKE X 00 DC - Solenoid-operated directional control valve size10 without coil

HK DKE X 00 AC - Solenoid-operated directional control valve size10 without coil

Accessories:

HK SP DIN 43650 - Electrical plug for solenoid coil DIN 43650 / ISO 4400

HK SP 42C**Coil for solenoid-operated directional control valve HK42C**

Scope of supply: with O-ring
Corresponding connectors: HKSP664, HKSP666, HKSP667, HKSP668

Note: As far as AC coils are concerned, power input is considerably higher in the take-up phase than in the stopping phase. These must therefore never be operated without a magnet core since there is a danger of overheating and the coil can burn through.
 A similar effect occurs if valves with AC magnets are operated with extremely high pulse frequencies (On / Off). In such cases the coils, which are often in the vicinity of the high power input, can also overheat. For such applications the use of RC coils with rectifier plugs is recommended.
 With DC coils extremely high power spikes can occur during powering down. We therefore recommend the use of plugs with protective circuits when using such coils.

Ordering information: Other types of coil on request

Identification	Nominal voltage +/- 10 %	Average power consumption		Average current consumption		Weight kg
		W	A	W	A	
HK SP 12V 42C	12 VDC	37	3,13	1,10		1,10
HK SP 24V 42C	24 VDC	36	1,50	1,10		1,10
HK SP 205V 42C	205 VDC	36	0,18	1,10		1,10
HK SP 115V 42C	115 VAC	41	0,99	0,52		0,52
HK SP 230V 42C	230 VAC	41	0,50	0,52		0,52

Web: <http://cat.hansa-flex.com/en/HKSP42C>

Spare part for following products:

HK 42 C1 (7/G/Q/R) - Solenoid-operated directional control valve NG10

Accessories:

HK SP DIN 43650 - Electrical plug for solenoid coil DIN 43650 / ISO 4400

HK UEB MUT - Cap nut for solenoid-operated directional control valve

HK SP DG4V5**Coil for HK DG4V5 solenoid-operated valve**

Corresponding connectors: HKSP664, HKSP666, HKSP667, HKSP668, HKSP669 (rectifier plug)

Note: As far as AC coils are concerned, power input is considerably higher in the take-up phase than in the stopping phase. These must therefore never be operated without a magnet core since there is a danger of overheating and the coil can burn through.
 A similar effect occurs if valves with AC magnets are operated with extremely high pulse frequencies (On / Off). In such cases the coils, which are often in the vicinity of the high power input, can also overheat. For such applications the use of RC coils with rectifier plugs is recommended.
 With DC coils extremely high power spikes can occur during powering down. We therefore recommend the use of plugs with protective circuits when using such coils.
 Tightening torque for attaching nuts of the solenoid coils: 3Nm

Ordering information: Other types of coil on request

Identification	Nominal voltage +/- 10 %	Average power consumption		Weight kg
		W	A	
HK DG4V5 G 12VDC	12 VDC	38	0,90	0,90
HK DG4V5 H 24VDC	24 VDC	38	0,90	0,90
HK DG4V5 A 110VAC	110 VAC	7	0,90	0,90
HK DG4V5 A 220VAC	230 VAC	7	0,90	0,90

Web: <http://cat.hansa-flex.com/en/HKSPDG4V5>

Spare part for following products:

HK DG4V5 - Solenoid-operated directional control valve NG10

Accessories:

HK SP DIN 43650 - Electrical plug for solenoid coil DIN 43650 / ISO 4400

HK SP EMDV

Coil for cartridge valve EMDV

Code contains coil, 2 part heat sink and type plate with fastenings.
A rectifier plug has to be used for solenoid coils Type HK230VACSEMDV08.
The solenoid coils Type HK230ACLEMDV1012 have a rectifier integrated into the coil.

Corresponding connectors: HKSP664, HKSP666, HKSP667, HKSP668

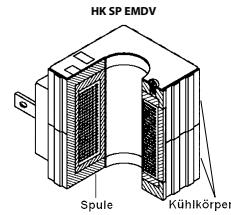

Note: As far as AC coils are concerned, power input is considerably higher in the take-up phase than in the stopping phase. These must therefore never be operated without a magnet core since there is a danger of overheating and the coil can burn through.

A similar effect occurs if valves with AC magnets are operated with extremely high pulse frequencies (On / Off). In such cases the coils, which are often in the vicinity of the high power input, can also overheat. For such applications the use of RC coils with rectifier plugs is recommended.

With DC coils extremely high power spikes can occur during powering down. We therefore recommend the use of plugs with protective circuits when using such coils.

Ordering information: Other types of coil on request

Identification	Nominal voltage +/- 10 %	Power consumption		for valve type	Weight kg
		W			
HK 12VDC L EMDV 60191	12 VDC	36		HK EMVD10 N01/HK EMVD10 NC1/HK EMVD 12	0,2
HK 12VDC S EMDV 60186	12 VDC	22		HK EMVD 08	0,2
HK 230VAC L EMDV 60191	230 VAC	36		HK EMVD10 N01/HK EMVD10 NC1/HK EMVD 12	0,2
HK 230VAC S EMDV 60186	230 VAC	22		HK EMVD 08	0,2
HK 24VDC L EMDV 60191	24 VDC	36		HK EMVD10 N01/HK EMVD10 NC1/HK EMVD 12	0,2
HK 24VDC S EMDV 60186	24 VDC	22		HK EMVD 08	0,2

Web: <http://cat.hansa-flex.com/en/HKSPEMDV>

Spare part for following products:

HK EMDV - 2/2-way solenoid-controlled seat valve EMDV

Accessories:

HK SP DIN 43650 - Electrical plug for solenoid coil DIN 43650 / ISO 4400

HK SP 770

Coil for cartridge valve SUN

Solenoid coil designed for 80% to 120% of the rated voltage at 100% CDF

Use: for 2/2-way solenoid-operated directional control valve HK DTDA

Corresponding connectors: HKSP664, HKSP666, HKSP667, HKSP668



Note: As far as AC coils are concerned, power input is considerably higher in the take-up phase than in the stopping phase. These must therefore never be operated without a magnet core since there is a danger of overheating and the coil can burn through.

A similar effect occurs if valves with AC magnets are operated with extremely high pulse frequencies (On / Off). In such cases the coils, which are often in the vicinity of the high power input, can also overheat. For such applications the use of RC coils with rectifier plugs is recommended.

With DC coils extremely high power spikes can occur during powering down. We therefore recommend the use of plugs with protective circuits when using such coils.

A rectifier is integrated into the 230 VAC coil

Ordering information: Other types of coil on request

Identification	Nominal voltage +/- 10 %	Power consumption		Average current consumption		Weight kg
		W		A		
HK 770 212	12 VDC	22		1,10		0,3
HK 770 224	24 VDC	22		0,50		0,3
HK 770 2230	230 VAC	22		0,22		0,3

Web: <http://cat.hansa-flex.com/en/HKSP770>

Spare part for following products:

HK DTDA - 2/2-way solenoid-operated directional control valve DTDA

Accessories:

HK SP DIN 43650 - Electrical plug for solenoid coil DIN 43650 / ISO 4400

HK SP DFE**Coil for solenoid-operated directional control valve HK DFE**

Corresponding connectors: HKSP664, HKSP666, HKSP667, HKSP668

Note: As far as AC coils are concerned, power input is considerably higher in the take-up phase than in the stopping phase. These must therefore never be operated without a magnet core since there is a danger of overheating and the coil can burn through.

A similar effect occurs if valves with AC magnets are operated with extremely high pulse frequencies (On / Off). In such cases the coils, which are often in the vicinity of the high power input, can also overheat. For such applications the use of RC coils with rectifier plugs is recommended.

With DC coils extremely high power spikes can occur during powering down. We therefore recommend the use of plugs with protective circuits when using such coils.

Ordering information: Other types of coil on request

Identification	Nominal voltage +/- 10 %	Power consumption W	for valve type	Weight kg
HK DFE 052 12VDC	12 VDC	38	HK DFE 052	0,38
HK DFE 052 24VDC	24 VDC	38	HK DFE 052	0,38
HK DFE 100 12VDC	12 VDC	60	HK DFE 100	1,08
HK DFE 100 24VDC	24 VDC	60	HK DFE 100	1,08
HK DFE 100 192VDC	192 VDC	60	HK DFE 100	1,08
HK DFE 200 12VDC	12 VDC	60	HK DFE 200	0,98
HK DFE 200 20VDC	20 VDC	60	HK DFE 200	0,98
HK DFE 200 24VDC	24 VDC	60	HK DFE 200	0,98
HK DFE 200 192VDC	192 VDC	60	HK DFE 200	0,98

Web: <http://cat.hansa-flex.com/en/HKSPDFE>

Spare part for following products:

HK DFE 3 - 3/2-way directional solenoid valve for pipeline installation

HK DFE 6 - 6/2-way directional solenoid valve for pipeline installation

Accessories:

HK SP DIN 43650 - Electrical plug for solenoid coil DIN 43650 / ISO 4400

HK SP DIN 43650
Electrical plug for solenoid coil DIN 43650 / ISO 4400

Design: Plug with central screw, type A
Standard: EN 175301-803 (DIN 43650) / ISO 4400
Operating temperature: -40 °C to +125 °C
Scope of supply: incl. seal and M3 screw
Material: Housing: Polyamide, Contacts: CuZn
protection class: IP 65

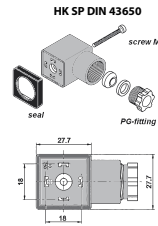

Identification	Colour	Design	Weight kg
HK SP 664	black	standard 4-pin	0,07
HK SP 664 A	grey	standard 4-pin	0,07
HK SP 666	black	standard 3-pin	0,07
HK SP 666 A	grey	standard 3-pin	0,07
HK SP 667 24	transparent	with LED for 12/24 V DC	0,07
HK SP 667 110	transparent	with LED for 110 V AC	0,07
HK SP 667 220	transparent	with LED for 230 V AC	0,07
HK SP 668 24	transparent / black	with LED 12/24 V and protective circuit	0,07
HK SP 668 24 A	transparent / grey	with LED 12/24 V and protective circuit	0,07
HK SP 669	black	with rectifier	0,07
HK SP 669 A	grey	with rectifier	0,07

HK SP 667 24, 667 110, 667 220

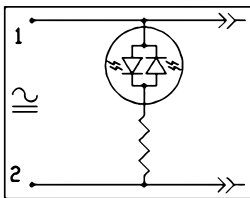

HK SP 668 24, 668 24 A

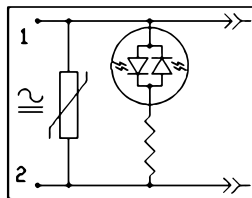

HK SP 669, 669 A

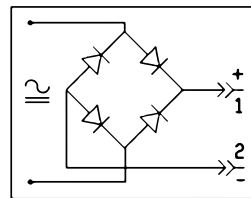

Web: <http://cat.hansa-flex.com/en/HKSPDIN43650>

Accessory for following products:

HK SP EMDV - Coil for cartridge valve EMDV
HK SP 770 - Coil for cartridge valve SUN
HK SP DFE - Coil for solenoid-operated directional control valve HK DFE
HK SP 41C - Coil for HK41C solenoid-operated valve
HK SP 42C - Coil for solenoid-operated directional control valve HK42C
HK SP CAE - Coil for solenoid-operated directional control valve HK DKE
HK SP CO - Coil for HKDH solenoid-operated valve

HK SPZ

Electrical connector for proportional valves



Design: Straight connector with screw connection
Operating temperature: -40 °C to +85 °C
Material: Housing: Polyamide, Contacts: CuZn
protection class: IP 67

1

Identification	Colour	Design	Weight kg
HK SPZ H5 P	black	M12, IEC60947, 5-pole, for proportional valves with digital electronic driver HK EMI AS IR	0,15
HK SPZ H7 P	black	DIN43563, 7-polig, for proportional valves integrated electronics	0,10

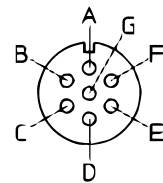
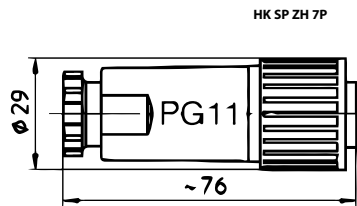
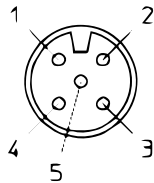
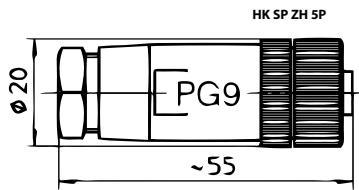

Web: <http://cat.hansa-flex.com/en/HKSPZ>

Accessory for following products:

- HK DLHZO TE - Proportional solenoid-operated directional control valve size 6
- HK DLKZOR TE - Proportional solenoid-operated directional control valve size 10
- HK RZMO AE 030 - Proportional pressure relief valve size 6
- HK RZGO AE 033 - Proportional pressure reducing valve size 6

HK M HK DH

Screw set for NG 6 valves type HK DH / DG4V3

Design: Hexagon socket screw
Standard: DIN 912-12.9



Identification	for valve type	Tightening torque		Scope of supply	Weight kg
		N-m			
HK M5 30	1 directional control valve	8,3			0,03
HK M5 70	1 directional control valve + 1 sandwich body valve	8,3			0,06
HK M5 110	1 directional control valve + 2 sandwich body valves	8,3			0,09
HK M5 150	1 directional control valve + 3 sandwich body valves	8,3			0,11

Web: <http://cat.hansa-flex.com/en/HKMHKDH>

Accessory for following products:

HK DH01 - Hand-operated directional control valve NG6
 HK DH04/05 - Directional control valve NG6, hydraulically controlled
 HK DH08/09 - Directional control valve NG6, pneumatically controlled
 HK DHA - Solenoid-operated directional control valve size 6, Ex-protected
 HK DHE X 00 DC - Solenoid-operated directional control valve size 6 without coil
 HK DHE X 00 AC - Solenoid-operated directional control valve size 6 without coil
 HK DHQ - High speed/creep speed unit for flow control valve QV
 HK DHZO A - Proportional solenoid-operated directional control valve size 6
 HK DLO - Poppet valve NG6
 HK DLHZO TE - Proportional solenoid-operated directional control valve size 6
 HK DG4V3 - Solenoid-operated directional control valve NG6

HK M HK DK

Set of bolts for NG 10 valves types HK DK11/DKE/DG4V5

Design: Hexagon socket screw
Standard: DIN 912-12.9



Identification	for valve type	Tightening torque		Scope of supply	Weight kg
		N-m			
HK M6 40	1 directional control valve	14,0			0,06
HK M6 90	1 directional control valve + 1 sandwich body valve	14,0			0,10
HK M6 140	1 directional control valve + 2 sandwich body valves	14,0			0,12
HK M6 190	1 directional control valve + 3 sandwich body valves	14,0			0,20

Web: <http://cat.hansa-flex.com/en/HKMHKDK>

Accessory for following products:

HK DK11 - Hand-operated directional control valve NG10
 HK DKE X 00 DC - Solenoid-operated directional control valve size 10 without coil
 HK DKE X 00 AC - Solenoid-operated directional control valve size 10 without coil
 HK DKZOR A - Proportional solenoid-operated directional control valve size 10
 HK DLKZOR TE - Proportional solenoid-operated directional control valve size 10
 HK DG4V5 - Solenoid-operated directional control valve NG10

HK M HK DPH 2

Set of bolts for NG16 valves type HK DPH 2



Design: Hexagon socket screw
Standard: DIN 912-12.9

Identification	for valve type	Tightening torque	Scope of supply	Weight
		N-m		kg
HK M5 30	1 directional control valve/1 pilot valve NG6 on directional control valve	8,3		0,03
HK M6 40	1 directional control valve NG16	14,0		0,06
HK M10 50	1 directional control valve NG16	63,0		0,15
HK M6 100	1-way directional control valve + 1 sandwich body valve NG 16 (plate height 60 mm)	14,0		0,10
HK M10 110	1-way directional control valve + 1 sandwich body valve NG 16 (plate height 60 mm)	63,0		0,30
HK M6 80 2	1-way directional control valve + 1 sandwich body valve NG 16 (plate height 40 mm)	14,0		0,10
HK M 10 90	1-way directional control valve + 1 sandwich body valve NG 16 (plate height 40 mm)	63,0		0,20

Web: <http://cat.hansa-flex.com/en/HKMHKDPH2>

Accessory for following products:

HK DPH 2 - Directional control valve NG16

HK M HK DPH 4

Set of bolts for NG25 valves type HK DPH 4



Design: Hexagon socket screw
Standard: DIN 912-12.9

Identification	for valve type	Tightening torque	Scope of supply	Weight
		N-m		kg
HK M5 30	1 directional control valve/1 pilot valve NG6 on directional control valve	8,3		0,03
HK M12 50	1 directional control valve NG25	120,0		0,03
HK M12 130	1-way directional control valve + 1 sandwich body valve NG 25 (plate height 80 mm)	120,0		0,50
HK M12 100 6	1-way directional control valve + 1 sandwich body valve NG 25 (plate height 50 mm)	120,0		0,30

Web: <http://cat.hansa-flex.com/en/HKMHKDPH4>

Accessory for following products:

HK DPH 4 - Directional control valve NG25

HK M HK 41 C

Set of bolts for NG6 valves type HK 41 C

Design: Hexagon socket screw
Standard: DIN 912-12.9



Identification	for valve type	Tightening torque		Scope of supply	Weight kg
		N-m			
HK M5 30	1 directional control valve	8,3			0,03
HK M5 60	1 directional control valve + 1 sandwich body valve (ZRV)	8,3			0,05
HK M5 70	1 directional control valve + 1 sandwich body valve	8,3			0,06
HK M5 80	1 directional control valve + 1 sandwich body valve (ZRV-AB)	8,3			0,07
HK M5 100	1 directional control valve + 2 sandwich body valves (with 1 x ZRV)	8,3			0,08
HK M5 110	1 directional control valve + 2 sandwich body valves	8,3			0,09
HK M5 120	1 directional control valve + 2 sandwich body valves (with 1 x ZRE-AB)	8,3			0,09
HK M5 140	1 directional control valve + 3 sandwich body valves (with 1 x ZRV)	8,3			0,10
HK M5 150	1 directional control valve + 3 sandwich body valves	8,3			0,11
HK M5 160	1 directional control valve + 3 sandwich body valves (with 1 x ZRE-AB)	8,3			0,12

Web: <http://cat.hansa-flex.com/en/HKMHK41C>

Accessory for following products:

HK 41 C1 - Hand-operated directional control valve NG6

HK 41 C1 (7/G/Q/R) - Solenoid-operated directional control valve NG6

HK M HK 42 C

Set of bolts for NG10 valves type HK 42 C

Design: Hexagon socket screw
Standard: DIN 912-12.9



Identification	for valve type	Tightening torque		Scope of supply	Weight kg
		N-m			
HK M6 40	1 directional control valve	14,0			0,06
HK M6 75	1 directional control valve + 1 sandwich body valve (ZRV)	14,0			0,08
HK M6 90	1 directional control valve + 1 sandwich body valve	14,0			0,10
HK M6 125	1 directional control valve + 2 sandwich body valves (with 1 x ZRV)	14,0			0,11
HK M6 140	1 directional control valve + 2 sandwich body valves	14,0			0,12
HK M6 175	1 directional control valve + 3 sandwich body valves (with 1 x ZRV)	14,0			0,16
HK M6 190	1 directional control valve + 3 sandwich body valves	14,0			0,20

Web: <http://cat.hansa-flex.com/en/HKMHK42C>

Accessory for following products:

HK 42 C1 (7/G/Q/R) - Solenoid-operated directional control valve NG10

HK M HK AGRL**Screw kit for non-return valve Type HK AGRL**

Design: Hexagon socket screw
Standard: DIN 912-12.9

Identification	for valve type	Tightening torque	Scope of supply	Weight kg
		N-m		
HK M10 45	1 HK AGRL 10 / 20 on sub-base	63,0		0,12
HK M10 1006	1 HK AGRL 32 on sub-base	63,0		0,17

Web: <http://cat.hansa-flex.com/en/HKMHKAGRL>

Accessory for following products:

HK AGRL - Non-return valve for plate mounting Cetop P

HK M HK QV**Screw set for flow control valve Type HK QV**

Design: Hexagon socket screw
Standard: DIN 912-12.9

Identification	for valve type	Tightening torque	Scope of supply	Weight kg
		N-m		
HK M5 70	1 HK QV 06 on sub-base or sandwich body HK BHQ	8,3		0,06
HK M8 80	1 HK QV 10 on sub-base	35,0		0,12
HK M10 80	1 HK QV 20 on sub-base	63,0		0,19

Web: <http://cat.hansa-flex.com/en/HKMHKQV>

Accessory for following products:

HK QV - Flow control valve for plate mounting Cetop

HK BHQ - Connection plate for flow control valve QV

HK SP WPD / SP SET / 6 OE

Emergency hand operation for directional solenoid valve

Design: as snapper or push button
Material: Plastic / steel
Use: for manual emergency operation of solenoid valves

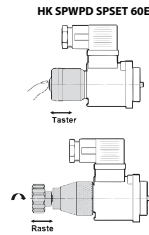

Identification	for valve type	Design	Weight kg
HK SP WPD H Q30	HK DHI	locking	0,1
HK SP SET 6DH 103500	HK DHI	Pushbutton	0,1
HK SP WPD HS	HK DHE DC	locking	0,1
HK 6 OE 101500	HK DHE DC	Pushbutton	0,1
HK SP SET 15AE 101500	HK DKE DC	Pushbutton	0,1
HK SP WPD KE DC	HK DKE DC	locking	0,3
HK SP SET 15AE 102500		Pushbutton	0,1
HK 6 OE 102500	HK DHE AC	Pushbutton	0,1

Web: <http://cat.hansa-flex.com/en/HKSPWPDSPSET6OE>

Accessory for following products:

HK DHE X 00 DC - Solenoid-operated directional control valve size 6 without coil
HK DHE X 00 AC - Solenoid-operated directional control valve size 6 without coil
HK DKE X 00 AC - Solenoid-operated directional control valve size 10 without coil
HK DKE X 00 DC - Solenoid-operated directional control valve size 10 without coil

HK UEB MUT

Cap nut for solenoid-operated directional control valve



Note: Tightening torque for attaching nuts of the solenoid coils: 3Nm

Identification	for valve type	Weight kg
HK SPSET 6OE 101116	HK DHE DC	0,03
HK SPSET 15AE 101116	HK DKE DC	0,05
HK 4D01 AC MUTTER	HK 41 with AC coil	0,05
HK 4D01 DC MUTTER	HK 41 with DC coil	0,05

Web: <http://cat.hansa-flex.com/en/HKUEBMUT>

HK HR SUN**Hand wheel for cartridge valve SUN**

For applications on SUN cartridge valves with frequent adjustments

Scope of supply: Handwheel and locking nut

Material: Plastic / steel

Identification	Thread	Weight kg
HK HR SUN	3/8" UNF IG	0,1

Web: <http://cat.hansa-flex.com/en/HKHRSUN>

Accessory for following products:

HK CB L - Overcentre valve CB

HK CK XCN - Non-return valve CK

HK FD - 2-way directional control valve FD

HK RD - Pressure relief valve RD

HK RP - Pressure relief valve RP

HK BLAK

Bladder accumulator

Design: Vertical installation position, gas side top
Operating pressure: max. 350 bar
Temp. range: Standard version -15 °C to +80 °C
Material: Bladder: NBR standard version



Note: Gas charge pressure p_0 – between $0.9 p_1$ and $0.25 p_2$ (p_1 = min. system pressure, p_2 = max. system pressure)
 CE label for all bladder accumulators
 Repair kits, see HK BLAK REPKIT

Ordering information: The accumulators will be delivered uncharged from stock. N2-chargings according to customer requirements arise separate costs.

Identification	Gas volume l L	p max. bar	A	B	C	$\varnothing D$	$\varnothing d$	E	F	$\varnothing G$	Weight kg
			mm	mm	mm	mm	mm	mm	mm	mm	
HK BLAK 1.0 350 114	1,0	350	334	216	54	114	35	64	G 1.1/4"	53	7,0
HK BLAK 2.5 350 114	2,5	350	533	415	54	114	35	415	G 1.1/4"	53	10,0
HK BLAK 4.0 350 114	4,0	350	420	302	54	168	35	64	G 1.1/4"	53	16,5
HK BLAK 5.0 350 114	5,0	350	882	764	54	114	35	64	G 1.1/4"	53	17,0
HK BLAK 6.0 350 114	6,0	350	546	428	54	168	35	64	G 1.1/4"	53	20,0
HK BLAK 10.0 350 2	10,0	350	811	693	54	168	35	64	G 1.1/4"	53	28,0
HK BLAK 10.0 330 K2	10,0	330	571	415	54	220	35	102	G 2"	76	32,0
HK BLAK 20.0 330 2	20,0	330	881	725	54	220	35	102	G 2"	76	53,0

pmax = max. working pressure

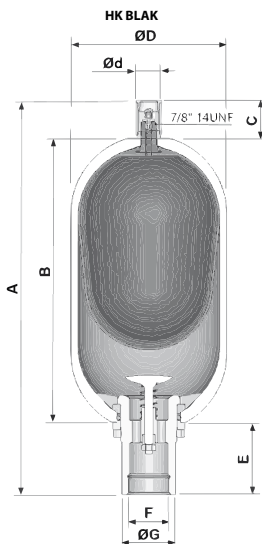

Web: <http://cat.hansa-flex.com/en/HKBLAK>

Spare parts:

HK BLAK REPKIT - Repair kit for bladder accumulator

Accessories:

HK SAB M - Safety and isolation block with manual relief

HK CD - Accumulator clamp

HK CE - Accumulator clamp

HK KONS - Console for bladder accumulators

HK AS - Accumulator adapters for safety and isolation block

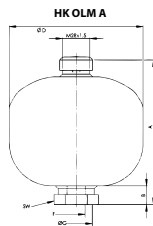
HK OLM A**Diaphragm accumulator, connection A**

Connections: Oil side type A - female thread
Design: Vertical installation position, gas side top
Operating pressure: max. 350 bar
Temp. range: Typ 1: -10 °C to +80 °C, Typ 2: -30 °C to +110 °C
Material: Diaphragm: NBR standard version

Note: Betriebsdruck 100 bis 350 bar, min. Betriebsdruck muss 10 % über Gasfülldruck liegen, max. Gasfülldruck 130 bar
 CE mark for diaphragm accumulators >1.0 l gas volume

Ordering information: The accumulators will be delivered uncharged from stock. N₂-chargings according to customer requirements arise separate costs.

Identification	Type	Gas volume l L	p max. bar	pma: p0	pmax - pmin bar	A mm	B mm	Ø D mm	Ø G mm	F	AF mm	Weight kg
HK OLM 0.075 250 A	1	0,075	250	8:1	210	111	20	64	29	G 1/2"	32	0,7
HK OLM 0.16 250 A	1	0,160	250	6:1	210	120	20	75	29	G 1/2"	32	1,0
HK OLM 0.16 250 ECO A	2	0,160	250	6:1	210	120	20	75	29	G 1/2"	32	1,0
HK OLM 0.32 210 A	1	0,320	210	8:1	175	140	20	95	29	G 1/2"	32	1,7
HK OLM 0.32 210 ECO A	2	0,320	210	8:1	175	140	20	95	29	G 1/2"	32	1,7
HK OLM 0.5 210 A	1	0,500	210	8:1	175	152	22	106	34	G 1/2"	41	2,0
HK OLM 0.75 210 A	1	0,750	210	8:1	175	169	22	124	34	G 1/2"	41	2,9
HK OLM 0.75 350 A	1	0,750	350	8:1	150	169	18	131	34	G 1/2"	41	3,5
HK OLM 1.0 210 A	1	1,000	210	8:1	170	180	22	136	34	G 1/2"	41	3,5
HK OLM 1.4 140 A	1	1,400	140	8:1	120	191	22	147	34	G 1/2"	41	4,2
HK OLM 1.4 210 A	1	1,400	210	8:1	120	191	22	148	34	G 1/2"	41	4,2
HK OLM 2.0 100 A	1	2,000	100	8:1	80	240	22	144	34	G 1/2"	41	3,5
HK OLM 2.0 250 A	1	2,000	250	6:1	140	251	22	155	33	G 3/4"	41	7,5
HK OLM 2.8 250 A	1	2,800	250	6:1	140	268	21	169	32	G 3/4"	41	9,0
HK OLM 2.8 250 ECO A	2	2,800	250	6:1	140	268	21	169	32	G 3/4"	41	9,0
HK OLM 3.5 250 A	1	3,500	250	4:1	140	307	22	169	32	G 3/4"	41	11,0

Typ 1: Standard Typ 2: low temperature version p0 = Gas charge pressure pmax - pmin = Admissible pressure fluctuation of the accumulator

Web: <http://cat.hansa-flex.com/en/HKOLMA>

Accessories:

HK SAB M - Safety and isolation block with manual relief

HK CE - Accumulator clamp

HK AS - Accumulator adapters for safety and isolation block

Diaphragm accumulator, connection C

Connections: Oil side type C - female thread and male thread
Design: Vertical installation position, gas side top
Operating pressure: max. 350 bar
Temp. range: Typ 1: -10 °C to +80 °C, Typ 2: -30 °C to +110 °C
Material: Diaphragm: NBR standard version

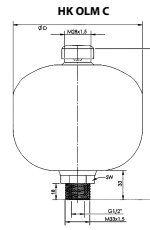

Note: Betriebsdruck 100 bis 350 bar, min. Betriebsdruck muss 10 % über Gasfülldruck liegen, max. Gasfülldruck 130 bar
 CE mark for diaphragm accumulators >1.0 l gas volume

Ordering information: The accumulators will be delivered uncharged from stock. N2-chargings according to customer requirements arise separate costs.

Bei Bedarf bitte Kontermutter HK MS M33-15 mitbestellen.

Identification	Type	Gas volume l L	p max. bar	p _{ma} : p ₀	p _{max} - p _{min} bar	A mm	B mm	Ø D mm	F	AF mm	Weight kg
HK OLM 0.5 210 C	1	0,500	210	8:1	175	163	33	106	G 1/2"	41	2,0
HK OLM 0.75 210 C	1	0,750	210	8:1	175	180	33	124	G 1/2"	41	2,9
HK OLM 0.75 210 ECO C	2	0,750	210	8:1	175	180	33	124	G 1/2"	41	2,9
HK OLM 0.75 350 ECO C	2	0,750	350	8:1	150	169	18	131	G 1/2"	41	3,5
HK OLM 1.0 210 C	1	1,000	210	8:1	170	191	33	136	G 1/2"	41	3,5
HK OLM 1.4 140 C	1	1,400	140	8:1	120	202	33	147	G 1/2"	41	4,2
HK OLM 1.4 210 C	1	1,400	210	8:1	120	202	33	148	G 1/2"	41	4,2
HK OLM 1.4 210 ECO C	2	1,400	210	8:1	120	202	33	148	G 1/2"	41	4,2
HK OLM 1.4 350 ECO C	2	1,400	350	8:1	150	220	33	160	G 1/2"	41	7,0

Typ 1: Standard Typ 2: low temperature version p₀ = Gas charge pressure p_{max} - p_{min} = Admissible pressure fluctuation of the accumulator

Web: <http://cat.hansa-flex.com/en/HKOLMC>

Accessories:

HK SAB M - Safety and isolation block with manual relief

HK CE - Accumulator clamp

HK MSM - Lock nuts for diaphragm accumulator C

HK BLAK REPKIT

Repair kit for bladder accumulator



Scope of supply: Replacement bladder, gas valve with protective cap, packing set oil fitting

Material: Bladder: NBR standard version

Connection: gas connection Ø22 mm, 7/8"-14UNF

Use: For bladder accumulator HK BLAK

Note: Repairs to pressure accumulators may only be carried out by qualified personnel! Please observe the repair instructions supplied.

Identification	for bladder accumulator	Weight kg
HK BLAK 1.0 REPKIT	HK BLAK1.0	0,5
HK BLAK 2.5 REPKIT	HK BLAK2.5	0,7
HK BLAK 4.0 REPKIT	HK BLAK4.0	1,0
HK BLAK 5.0 REPKIT	HK BLAK5.0	1,0
HK BLAK 6.0 REPKIT	HK BLAK6.0	1,5
HK BLAK 10.0 REPKIT	HK BLAK10.0	1,6
HK BLAK 10.0 K REPKIT	HK BLAK10.0K	1,6
HK BLAK 20.0 REPKIT	HK BLAK20.0	2,5

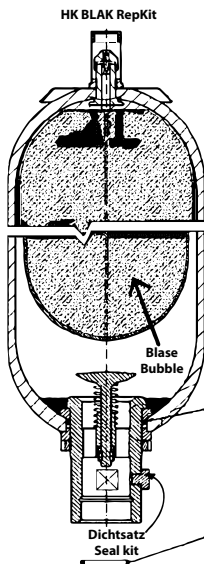

Web: <http://cat.hansa-flex.com/en/HKBLAKREPKIT>

Spare part for following products:

HK BLAK - Bladder accumulator

HK VGU GAS VENT**Gas valve kit for bladder accumulators**

Use: For bladder accumulator HK BLAK

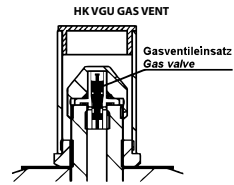

Note: Tightening torque: 0.25 - 0.29 Nm

Identification	Thread	Weight kg
HK VGU GASVENT	7/8"-14UNF AG	0,10

Web: <http://cat.hansa-flex.com/en/HKVGUGASVENT>

Spare part for following products:
HK BLAK - Bladder accumulator

HK SAB M**Safety and isolation block with manual relief**

The safety and isolation block is used to protect, shut off and discharge hydraulic accumulators. It is designed and manufactured in accordance with Directive 97/23/EC (PED), Article 3 Para. 3 and takes into account the European safety regulations for the operation of hydraulic accumulators. Discharging the accumulator is done manually at a ball valve or a relief valve.

Viscosity of the fluids must lie within the following limits:
min. 10 mm²/s, max. 380 mm²/s

Design: Safety valve
Operating pressure: max. 350 bar
Additional feature: with TÜV certification
Material: Gasket: NBR
Connection: for accumulator M33x2

Note: Safety valve is preset; observe the maximum pressure when allocating to the corresponding accumulator!

Identification	p max. bar	A mm	B mm	C mm	D mm	E mm	F mm	F1 mm	G mm	M1	M2	P	T	Weight kg
HK SAB 10 M 100	100	79	79	27	50	25	25	42	85	1/4"	1/4"	1/2"	1/2"	5,2
HK SAB 10 M 140	140	79	79	27	50	25	25	42	85	1/4"	1/4"	1/2"	1/2"	5,2
HK SAB 10 M 200	200	79	79	27	50	25	25	42	85	1/4"	1/4"	1/2"	1/2"	5,2
HK SAB 10 M 211	211	79	79	27	50	25	25	42	85	1/4"	1/4"	1/2"	1/2"	5,2
HK SAB 10 M 250	250	79	79	27	50	25	25	42	85	1/4"	1/4"	1/2"	1/2"	5,2
HK SAB 10 M 330	330	79	79	27	50	25	25	42	85	1/4"	1/4"	1/2"	1/2"	5,2
HK SAB 20 M 330	330	98	98	35	70	30	35	40	168	1/2"	1/4"	1"	1/2"	8,5

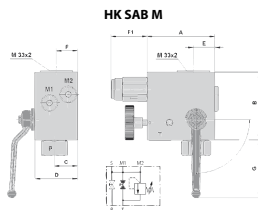

Web: <http://cat.hansa-flex.com/en/HKSABM>

Accessories:

HK AS - Accumulator adapters for safety and isolation block

HK MSM - Lock nuts for diaphragm accumulator C

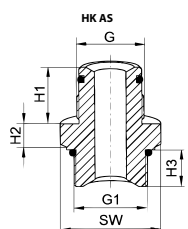
HK AS**Accumulator adapters for safety and isolation block**

For connection to pressure accumulators with safety and shut-off block

Material: Steel

Identification	for accumulator type	G	G1	H1 mm	H2 mm	H3 mm	AF mm	Weight kg
HK AS 10 3/4	Bladder accumulator with G3/4" connection	G 3/4"	M 33 x 2	27	18	21	41	0,4
HK AS 12 1 1/4	Bladder accumulator with G1.1/4" connection	G 1.1/4"	M 33 x 2	37	17	21	50	0,4
HK AS 13 2	Bladder accumulator with G2" connection	G 2"	M 33 x 2	44	21	21	65	1,1
HK AS 31 3/4	Diaphragm accumulator with G3/4" connection A	G 3/4"	M 33 x 2	14	18	21	41	0,4
HK AS 32 1/2	Diaphragm accumulator with G1/2" connection A	G 1/2"	M 33 x 2	14	16	21	41	0,3

Web: <http://cat.hansa-flex.com/en/HKAS>

Accessory for following products:

HK SAB M - Safety and isolation block with manual relief

HK OLM A - Diaphragm accumulator, connection A

HK BLAK - Bladder accumulator

HK MSM

Lock nuts for diaphragm accumulator C

Use: For diaphragm accumulator HK OLM C

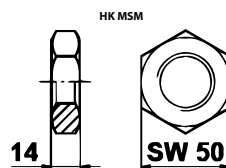

Identification	Thread	Weight kg
HK MS M33-15	M 33 x 1.5	0,05

Web: <http://cat.hansa-flex.com/en/HKMSM>

Accessory for following products:

HK OLM C - Diaphragm accumulator, connection C

HK CE

Accumulator clamp

Use: To fasten pressure accumulators

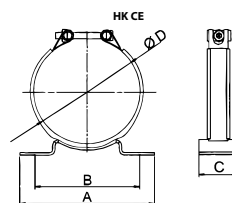

Note: Accumulator clamps are designed for static operation.

Identification	Clamping range (mm)	A mm	B mm	C mm	Ø D mm	Weight kg
HK CE 75	74 - 77	120	93	40	75	0,50
HK CE 95	87 - 97	155	114	40	95	0,65
HK CE 106	99 - 109	155	114	50	106	0,65
HK CE 114	112 - 124	155	114	50	114	0,75
HK CE 136	128 - 138	155	114	50	136	0,85
HK CE 155	146 - 157	210	163	50	155	1,00
HK CE 168	167 - 179	210	163	60	168	1,00

Web: <http://cat.hansa-flex.com/en/HKCE>

Accessory for following products:

HK OLM A - Diaphragm accumulator, connection A

HK OLM C - Diaphragm accumulator, connection C

HK BLAK - Bladder accumulator

HK CD

Accumulator clamp

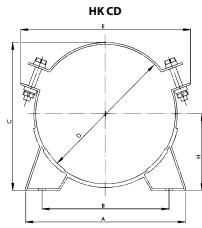

Use: To fasten pressure accumulators

Note: Accumulator clamps are designed for static operation.

Identification	Clamping range (mm)	A mm	B mm	C mm	Ø D mm	E mm	H mm	Weight kg
HK CD 226	219 - 226	270	216	241	226	295	123	1,40

Web: <http://cat.hansa-flex.com/en/HKCD>

Accessory for following products:

HK BLAK - Bladder accumulator

HK KONS

Console for bladder accumulators



Bracket for simple and secure mounting of the accumulators
Vibration-damping with NBR rubber ring

Material: Console: Steel, galvanised, Rubber ring: NBR
Use: To fasten pressure accumulators

Identification	for accumulator type	A mm	B mm	C mm	Ø D mm	E mm	F mm	G mm	K mm	Ø L mm	Weight kg
HK KONS 114		140	60	140	100	73	75	35		17	0,5
HK KONS 168	HK BLAK Ø168 mm	210	100	175	120	92	160	35	40	17	1,5
HK KONS 219	HK BLAK Ø219 mm	260	100	235	170	123	200	35	40	17	2,5

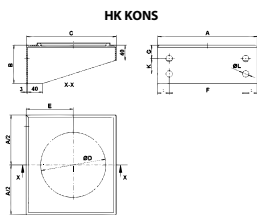

Web: <http://cat.hansa-flex.com/en/HKKONS>

Accessory for following products:

HK BLAK - Bladder accumulator

HK VGU

VGU tester and charging unit

The precharge pressure of hydraulic accumulators can be checked, reduced and increased. Fits on all bladder accumulators and diaphragm accumulators with M28 x 1.5 charging port.

Scope of supply: Tester and charging unit with 2 pressure gauges (0-25 bar / 0-250 bar) and connection M28x1.5, Protective case, Connection adapter 7/8" long, Connection adapter 5/8", High-pressure hose 2.5 m long, Allen key size 6, Replacement seals, Operating manual



Note: Caution! Use only technical nitrogen for charging, never oxygen or air!
Risk of explosions!

Identification	Weight
HK VGU BSD 25 250	kg 2,50

Web: <http://cat.hansa-flex.com/en/HKVGU>

HK OILAIR 2000

Oil-air cooler



Cooling element standard, without bypass
Cooling performance and pressure drop see chart

Design: with compact electric motor
Oil inlet temperature max.: 120 °C
Static working pressure max.: 20 bar

Note: For type HK OILAIR 2005 K no direct thermostat mounting is possible.

Ordering information: Cooler without thermostat, please order separately!

Identification	Motor	n 50 Hz rpm	Power kW	Air volume m ³ /h	LP dBA	Connection	Weight kg
HK OILAIR 2005 K	230V 50 Hz - Compact	2650	0,02	125	47	G 1/2"	3,2
HK OILAIR 2010 K	230V 50 Hz - Compact	2500	0,05	235	67	G 1/2"	6,0
HK OILAIR 2020 K	230/400V 50/60 Hz - Compact	2600	0,07	645	68	G 1"	8,0
HK OILAIR 2024 K	230/400V 50/60 Hz - Compact	2500	0,10	1300	72	G 1"	11,0
HK OILAIR 2040 K	230/400V 50/60 Hz - Compact	1245	0,29	3200	71	G 1 1/4"	21,0

LP = sound pressure level dB(A)

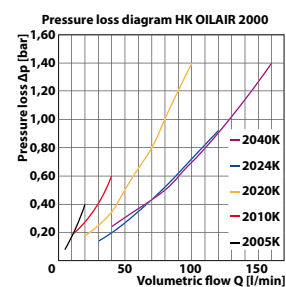
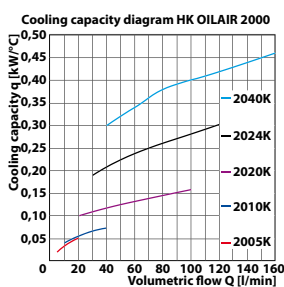
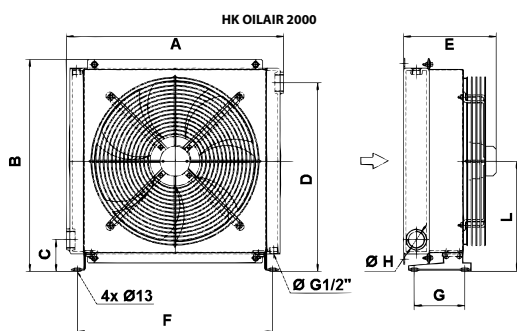

	A	B	C	D	E	F	G	H	L
	in mm	in mm	in mm	in mm	in mm	in mm	in mm	in mm	in mm
HK OILAIR 2005 K	146,0	190,0	17,5	155,0	114,5	101,0	--	G 1/2"	95,0
HK OILAIR 2010 K	224,0	249,0	55,0	233,0	175,0	120,0	125,0	G 1/2"	144,0
HK OILAIR 2020 K	320,0	304,5	83,0	241,0	150,0	273,0	125,0	G 1"	162,0
HK OILAIR 2024 K	380,0	366,0	82,0	304,0	168,0	325,0	125,0	G 1"	193,0
HK OILAIR 2040 K	445,0	430,0	84,5	367,5	178,0	390,0	125,0	G 1"	226,0

Web: <http://cat.hansa-flex.com/en/HKOILAIR2000>

Additional info: The cooling capacity curves are based on the inlet oil temperature and the ambient air temperature. For example an oil temperature of 60 °C and an air temperature of 20 °C produce a temperature difference of 40 °C. Multiply by kW/°C for total cooling capacity.

Accessories:

HK TM 4 - Thermostat for oil/air cooler

HK OILAIR HPA

Oil/air coolers

Cooling element standard, without bypass

Cooling performance and pressure drop see chart

Design: with electric motor type B14

Oil inlet temperature max.: 120 °C

Static working pressure max.: 20 bar

Ordering information: Cooler without thermostat, please order separately!

Identification	Motor	n 50 Hz rpm	Power kW	Air volume m ³ /h	LP dBA	Connection	Weight kg
HK OILAIR HPA30	230/400V 50/60 Hz - B14	1450	0,75	4000	82	G 1.1/4"	37,0
HK OILAIR HPA36	230/400V 50/60 Hz - B14	1450	1,10	5650	82	G 1.1/4"	60,0
HK OILAIR HPA52	230/400V 50/60 Hz - B14	980	1,10	7050	80	G 1 1/2"	95,0

LP = sound pressure level dB(A)

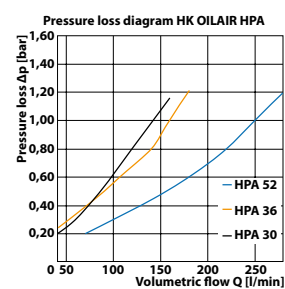
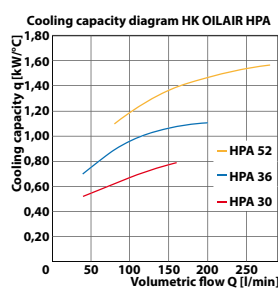
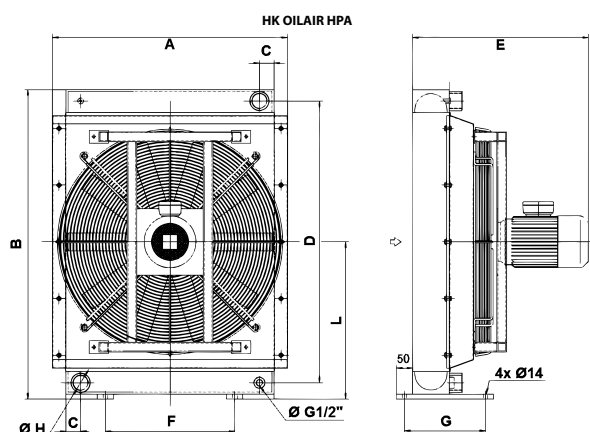

	A	B	C	D	E	F	G	H	L
	in mm	in mm	in mm	in mm	in mm	in mm	in mm	in mm	in mm
HK OILAIR HPA30	485,0	685,0	43,0	614,0	452,0	200,0	250,0	G 1 1/4"	350,0
HK OILAIR HPA36	610,0	785,0	45,0	714,0	460,0	310,0	250,0	G 1 1/4"	400,0
HK OILAIR HPA52	725,0	955,0	50,0	870,0	573,0	400,0	250,0	G 1 1/2"	485,0

Web: <http://cat.hansa-flex.com/en/HKOILAIRHPA>
Additional info: The cooling capacity curves are based on the inlet oil temperature and the ambient air temperature. For example an oil temperature of 60 °C and an air temperature of 20 °C produce a temperature difference of 40 °C. Multiply by kW/°C for total cooling capacity.

Accessories:

HK TM 4 - Thermostat for oil/air cooler

HK TM 4

Thermostat for oil/air cooler

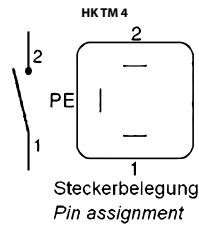

Design: NC contact
Operating temperature max.: 120 °C
Protection IP: IP 65
Material: Brass

Identification	Nominal switching point °C	ON switching point °C	OFF switching point °C	Weight kg
HK TM 45A 50	50	50 ± 3.5	38 ± 3.5	0,7
HK TM 46A 60	60	60 ± 3.5	48 ± 3.5	0,7
HK TM 47A 70	70	70 ± 3.5	58 ± 3.5	0,7
HK TM 48A 80	80	80 ± 3.5	68 ± 3.5	0,7

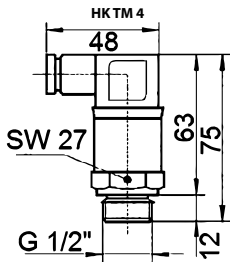

Web: <http://cat.hansa-flex.com/en/HKTM4>

Accessory for following products:

HK OILAIR 2000 - Oil-air cooler

HK OILAIR HPA - Oil/air coolers

HK BAK RA
BAKRA hydraulic tank

Sturdy cast aluminium body (GD-ALSi9Cu3 / EN AC-46500)
 Continuous groove for O-ring or flat gasket for the cover
 Low weight
 Good heat transmission due to high thermal conductivity coefficient
 Floor with incline on all sides towards the oil drain (in accordance with VDI Directive 3230)
Material: Aluminium
Scope of supply: without steel cover and cover gasket



1

Ordering information: Baffle plates are optionally available for HK BAK RA 130.

Identification	Useful volume V [l]	Cooling capacity kW	A	E	B	C	D	F	G	H	Weight kg
	L		mm	mm	mm	mm	mm	mm	mm	mm	
HK BAK RA 03	3	0,16	220	160	150	165,0	G 1/4"	105,0	4x M6x8	120	1,4
HK BAK RA 06	6	0,36	260	220	180	200,0	G 3/8"	160,0	4x M6x8	150	1,7
HK BAK RA 12	10	0,60	310	240	215	225,0	G 3/8"	155,0	4x M8x12	165	2,3
HK BAK RA 20	17	0,72	366	288	245	270,0	G 1/2"	192,0	4x M8x12	165	4,3
HK BAK RA 30	27	0,92	490	340	275	326,0	G 1/2"	176,0	4x M10x10	134	5,0
HK BAK RA 44	40	1,04	515	415	305	341,0	G 1/2"	241,0	4x M10x14	244	7,0
HK BAK RA 70	63	1,16	605	465	355	422,5	G 1/2"	282,5	4x M10x14	294	7,0
HK BAK RA 130	123	2,10	757	597	396	557,0	G 1/2"	397,0	4x M10x14	285	25,0

Weight: (without cover) kg Cooling capacity* P [kW] ($\Delta t = 40 \text{ K}$): Cooling capacity depending on the ambient conditions Dimension H: Assembly surface for fill level indicator

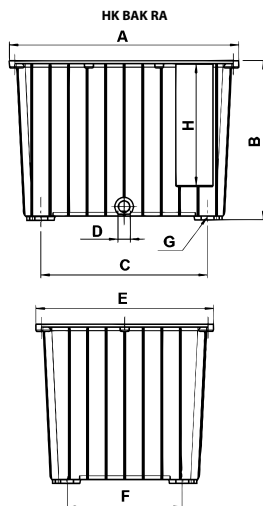

Web: <http://cat.hansa-flex.com/en/HKBAKRA>

Accessories:

HK ST BAK RA - Steel cap for hydraulic tank BAKRA
HK RS BAK RA - Gasket for hydraulic tank BAKRA
HK FUSS BAK RA - Foot for aluminium tank Type BAK RA
HK LR BAK RA - Castor for aluminium tank Type BAK RA

HK ST BAK RA**Steel cap for hydraulic tank BAKRA****Material:** Steel ST 37.2

Identification	for tank size	Recommended screw set	Weight kg
HK ST BAK RA 03	HK BAK RA 03	6 off M6x20	1,2
HK ST BAK RA 06	HK BAK RA 06	8 off M6x15	1,4
HK ST BAK RA 12	HK BAK RA 12	10 off M6x15	2,5
HK ST BAK RA 20	HK BAK RA 20	8 off M8x15	3,6
HK ST BAK RA 30	HK BAK RA 30	8 off M8x15	6,4
HK ST BAK RA 44	HK BAK RA 44	8 off M8x15	8,5
HK ST BAK RA 70	HK BAK RA 70	8 off M8x15	10,5
HK ST BAK RA 130	HK BAK RA 130	8 off M8x15	21,0

The recommended screw set is not included in scope of supply!

Web: <http://cat.hansa-flex.com/en/HKSTBAKRA>**Accessory for following products:****HK BAK RA** - BAKRA hydraulic tank**HK RS BAK RA****Gasket for hydraulic tank BAKRA**

For seal between aluminium tank and cover

Material: Flat gasket: Cardboard, O-ring seal: NBR

Identification	for tank size	Design	Weight kg
HK RS BAK RA 03	HK BAK RA 03	Flat seal	0,1
HK RS BAK RA 06	HK BAK RA 06	Flat seal	0,1
HK RS BAK RA 12	HK BAK RA 12	Flat seal	0,1
HK RS BAK RA 20	HK BAK RA 20	Flat seal	0,1
HK RS BAK RA 30	HK BAK RA 30	O-ring seal	0,1
HK RS BAK RA 44	HK BAK RA 44	O-ring seal	0,1
HK RS BAK RA 70	HK BAK RA 70	O-ring seal	0,1
HK RS BAK RA 130	HK BAK RA 130	O-ring seal	0,1

Web: <http://cat.hansa-flex.com/en/HKRSBAKRA>**Accessory for following products:****HK BAK RA** - BAKRA hydraulic tank

HK FUSS BAK RA

Foot for aluminium tank Type BAK RA

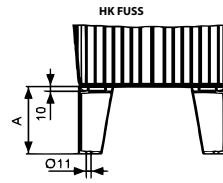
Material: Aluminium

Identification	for tank size	A mm	Mounting	Weight kg
HK FUSS 75 ALU	HK BAK RA 12 - 20	75	M8	0,1
HK FUSS 150 ALU	HK BAK RA 30 - 70	150	M10	0,2

Web: <http://cat.hansa-flex.com/en/HKFUSSBAKRA>
Accessory for following products:
 HK BAK RA - BAKRA hydraulic tank

HK LR BAK RA

Castor for aluminium tank Type BAK RA

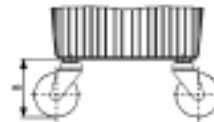
Material: Plastic / steel

Note: Due to the small dimensions for the tank HKBAKRA30 only 2 swivel castors should be used.

Identification	for tank size	B mm	Mounting	Weight kg
HK LENKROLLE 150	HK BAK RA 30 - 70	160	M10	1,1

Web: <http://cat.hansa-flex.com/en/HKLRBAKRA>
Accessory for following products:
 HK BAK RA - BAKRA hydraulic tank

HK OEW BAK

Oil tray for alu tank, Type BAK

Collecting volume = useful tank volume

 Version with special type plate and acceptance pursuant to §19 WHG
 (German Water Resources Act) available at additional charge on request

Design: with inner bar to mount the tank, without feet

Surface: powdercoated RAL 9006 Alu-Gray

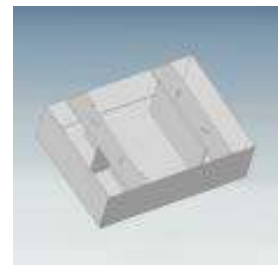
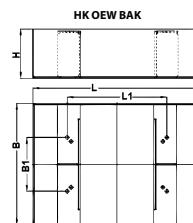
Material: Steel

Identification	B mm	B1 mm	H mm	L mm	L1 mm	Weight kg
HK OEW BAK RA30	400	176	160	550	326	20,1
HK OEW BAK RA44	500	241	160	600	341	26,2
HK OEW BAK RA70	580	283	160	730	423	30,6
HK OEW BAK RA130	770	397	210	920	577	59,0

Web: <http://cat.hansa-flex.com/en/HKOEWBAK>
Accessory for following products:
 HK BAK RA - BAKRA hydraulic tank

HK BEK

BEK hydraulic tank (without cleaning hatch)

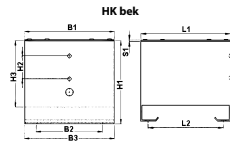

Tanks of quality steel, sandblasted, primer coating inside and outside with high-quality zinc dust paint that is resistant to mineral-oil based hydraulic oils. All tanks are subjected to 100% leak test.

Design: without cleaning hatch, with gasket

Material: Steel, Gasket: NBR

Note: Drain bolt G1/2" to HKBEK60 / G1" from HKBEK75

Identification	Useful volume V [l] L	B1 mm	H1 mm	L1 mm	B2 mm	L2 mm	H2 mm	B3 mm	H3 mm	S1 mm	Weight kg
HK BEK 12	16	298	275	310	220	260	76	310	220	4	17
HK BEK 20	26	298	325	400	220	350	76	310	270	4	23
HK BEK 35	40	298	400	470	220	420	76	310	345	5	30
HK BEK 50	58	388	420	500	310	450	76	400	365	5	39
HK BEK 60	69	388	445	550	310	500	76	400	390	5	43
HK BEK 75	85	388	530	550	310	500	127	400	475	5	46
HK BEK 100	109	388	530	700	310	650	127	400	475	6	57
HK BEK 150	175	488	620	750	410	700	127	500	565	6	77
HK BEK 225	267	588	650	900	510	850	127	600	595	8	110
HK BEK 300	339	688	700	900	610	850	127	700	645	8	127

Web: <http://cat.hansa-flex.com/en/HKBEK>

BSK hydraulic tank (with cleaning hatch)

Tanks of quality steel, sandblasted, primer coating inside and outside with high-quality zinc dust paint that is resistant to mineral-oil based hydraulic oils. All tanks are subjected to 100% leak test.

Design: with cleaning hatch and gasket

Material: Steel, Gasket: NBR



Note: Up to BG 200 with 1 cleaning hatch
Above BG 250 with 2 cleaning hatches
Drain bolt G1"

Ordering information: Viton gasket for cleaning hatch available on request.

Identification	Useful volume V [l]	B1	H1	L1	B2	L2	H2	B3	Ø D1	L3	Ø D2	S1	S2	S3	Weight
	L	mm	mm	mm	mm	mm	mm	mm	mm	mm	mm	mm	mm	mm	kg
HK BSK 40	38	375	430	508	315	428	280	30	200		250,0	3	3	6	33
HK BSK 63	59	375	560	508	315	428	410	30	248		324,0	3	3	6	42
HK BSK 100	92	474	560	633	414	553	407	30	248		324,0	4	4	6	63
HK BSK 160	152	604	560	810	544	730	410	30	248		324,0	4	4	6	88
HK BSK 200	184	654	560	900	594	820	410	30	248		324,0	4	4	6	101
HK BSK 250	235	704	580	1010	644	930	430	30	248	410	324,0	4	4	7	123
HK BSK 300	272	714	580	1208	654	1128	412	30	248	410	324,0	4	4	7	141
HK BSK 400	375	749	580	1514	689	1434	430	30	248	750	324,0	4	7	7	201

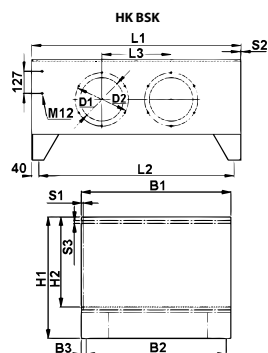

Web: <http://cat.hansa-flex.com/en/HKBSK>

Spare parts:

HK BSK RD - Cleaning hatch cover for steel tank, Type BSK

Accessories:

HK OEW BSK - Oil tray for steel tank, Type BSK

HK DB MOS

Sealing tape for tanks



Sealing tape for tank cap of hydraulic tanks

Design: Metre goods
Material: NBR foam rubber

Identification	Width mm	Strength mm	Weight / meter kg
HK DICHTBAND MOOSGUM	15	5,00	0,03

Web: <http://cat.hansa-flex.com/en/HKDBMOS>

HK OEW BSK

Oil tray for steel tank, Type BSK



Collecting volume = useful tank volume

100% leak tested

Version with special type plate and acceptance pursuant to §19 WHG (German Water Resources Act) available at additional charge on request

Design: without feet
Surface: Primer with zinc dust paint, mineral oil resistant
Material: Steel

Identification	Volume	B	B1	H	L	L1	Weight kg
	L	mm	mm	mm	mm	mm	
HK OEW 63 BSK	74	600	315	200	700	428	22
HK OEW 100 BSK	105	700	414	200	850	553	29
HK OEW 160 BSK	160	800	544	200	1000	730	36
HK OEW 200 BSK	200	850	594	220	1100	820	42
HK OEW 250 BSK	250	1000	644	200	1250	930	50
HK OEW 300 BSK	300	900	654	250	1400	1128	57
HK OEW 400 BSK	400	1000	689	250	1700	1434	72

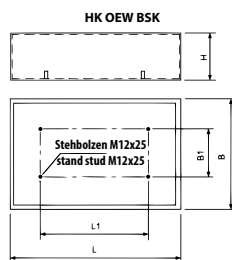

Web: <http://cat.hansa-flex.com/en/HKOEWBSK>

Accessory for following products:

HK BSK - BSK hydraulic tank (with cleaning hatch)

HK BSK RD

Cleaning hatch cover for steel tank, Type BSK

Servicing cover for steel tank type BSK (from size 63) with HANSA-FLEX logo

Design: Pitch circle diameter 324 mm, incl. seal

Material: Cast iron, Aluminium

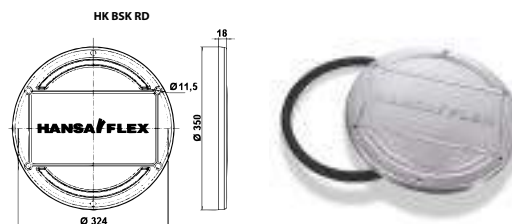

Identification

HK BSK RD 324 HF

Weight

kg
1,30

Web: <http://cat.hansa-flex.com/en/HKBSKRD>

Spare part for following products:

HK BSK - BSK hydraulic tank (with cleaning hatch)

FI BL GP

Tank venting filters

Design: Screw-in version, Typ FI BL 080 SS with antisurge baffle

Temp. min.: -30 °C

Temp. max.: 100 °C

Material: Housing: Polyamide

Filter material: organisch

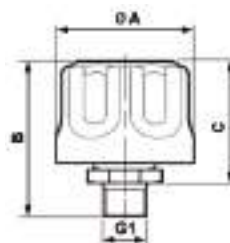

Identification	Filter mesh size	Air volume L/min	B mm	C mm	G1	Ø A mm	Weight kg
	µm						
FI BL 046 G P10	10	200	53	40	G 1/4"	46,00	0,13
FI BL 080 G3/4 P	10	120	67	15	G 3/4"	80,00	0,13
FI BL 080 G P03	3	450	71	55	G 3/4"	80,00	0,33
FI BL 080 G P10	10	550	71	55	G 3/4"	80,00	0,33
FI BL 080 SS	10	550	71	55	G 3/4"	80,00	0,40

Web: <http://cat.hansa-flex.com/en/FIBLGP>

FI BL FP

Tank venting filters



Design: Flange mounting on the tank, with filler screen, Typ FI BL 080 F P10 003 lockable
Temp. min.: -25 °C
Temp. max.: 100 °C
Material: Chrome-plated steel, cork gasket
Filter material: non-organic

Identification	Filter mesh size	Air volume	B	Mounting	C	L	Bolt circle	Ø A	Ø D	Ø E	Tank bore	Weight
	µm	L/min										
FI BL 046 F P03 002	3	150	110	3 x M5	46	64,0	41	46,00	52	28	30 mm	0,10
FI BL 046 F P10 002	10	200	110	3 x M5	46	64,0	41	46,00	52	28	30 mm	0,10
FI BL 080 F P03 080	3	450	141	6 x M5	61	80,0	73	80,00	83	50	51 mm	0,33
FI BL 080 F P03 150	3	450	211	6 x M5	61	150,0	73	80,00	83	50	51 mm	0,33
FI BL 080 F P10 003	10	550	141	6 x M5	61	80,0	73	80,00	83	50	51 mm	0,33
FI BL 080 F P10 080	10	550	141	6 x M5	61	80,0	73	80,00	83	50	51 mm	0,33
FI BL 080 F P10 150	10	550	211	6 x M5	61	150,0	73	80,00	83	50	51 mm	0,33

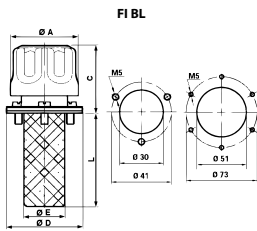

Web: <http://cat.hansa-flex.com/en/FIBLFP>

FI BL 116

Tank venting and filler filters

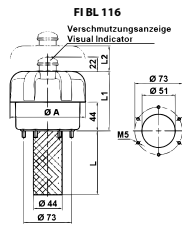

Design: Flange mounting on the tank, with filler screen, with clogging indicator
Temp. min.: -25 °C
Temp. max.: 100 °C
Material: Plastic cap, Gasket: NBR, Steel sieve
Filter material: non-organic, 3µm
Scope of supply: incl. filter element

Identification	Air volume	Mounting	L	L1	L2	Bolt circle	Ø A	Tank bore	Weight
	L/min								
FI BL 116 F P03 001	1600	6 x M5	108,0	91,0	55,0	73	116,00	51 mm	0,46
FI BL 116 F P03 002	2150	6 x M5	108,0	155,0	55,0	73	116,00	51 mm	0,60

Web: <http://cat.hansa-flex.com/en/FIBL116>

Spare parts:
 FI BL E MP - Venting filter element

FI BL E MP

Venting filter element

Filter material: non-organic, 3µm
Use: For tank venting filters



Identification	for filter type	L mm	Ø A mm	Ø D mm	Ø E mm	Weight kg
FI BL E MP 0071 P03	FI BL 116 F P03 001	72,0	83,00	42	54	0,2
FI BL E MP 0072 P03	FI BL 116 F P03 002	135,0	83,00	42	54	0,2

Web: <http://cat.hansa-flex.com/en/FIBLEMP>

Spare part for following products:
FI BL 116 - Tank venting and filler filters

HK TSF

Tank venting filters

Suitable also for dusty environments

Design: Screw-in plug with ventilation-filter bronze 40 µm, incl. seal

Temp. range: -20 °C to +100 °C

Material: Steel

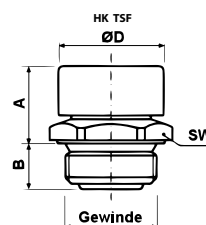

Identification	Thread	A mm	B mm	Ø D mm	AF mm	Weight kg
HK TSF 1 G14	G 1/4"	17	8	17	17	0,01
HK TSF 2 G38	G 3/8"	19	10	22	22	0,03
HK TSF 3 G12	G 1/2"	21	12	26	27	0,04
HK TSF 4 G34	G 3/4"	24	14	30	32	0,06
HK TSF 5 G1	G 1"	29	16	38	40	0,08
HK TSF 6 G114	G 1.1/4"	33	16	50	50	0,10
HK TSF 7 G112	G 1.1/2"	35	16	55	55	0,12
HK TSF 8 G2	G 2"	40	16	70	70	0,14
HK TSF 1 M1415	M 14 x 1.5	17	8	17	17	0,01
HK TSF 2 M1615	M 16 x 1.5	19	10	22	22	0,03
HK TSF 3 M1815	M 18 x 1.5	19	10	22	22	0,04
HK TSF 4 M2015	M 20 x 1.5	21	12	24	24	0,06
HK TSF 5 M2215	M 22 x 1.5	21	12	26	27	0,06
HK TSF 6 M2420	M 24 x 2	24	12	30	30	0,10
HK TSF 7 M3020	M 30 x 2	25	14	30	36	0,12
HK TSF 8 M3320	M 33 x 2	29	16	38	40	0,14

AF = Width across flats

Web: <http://cat.hansa-flex.com/en/HKTSF>

HK TKT G

Sealing cap

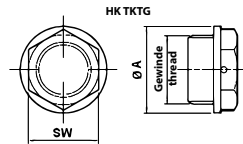

Design: without ventilation
Temp. range: -25° C to +100° C
Material: Plastic

Identification	Thread	External Ø mm	AF mm	Labelling	Weight kg
HK TKT G20 NOASF	G 1/2"	28	22	OIL	0,05

Web: <http://cat.hansa-flex.com/en/HKTKTG>

HK TSD G

Sealing cap / oil dipstick

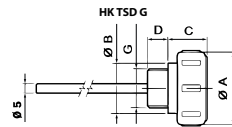

Design: with / without oil dipstick, with tank breather filters steel 90 µm
Material: Plastic / steel, Gasket: NBR

Identification	G	Ø A mm	Ø B mm	C mm	D mm	Length of dipstick	Labelling	Weight kg
HK TSD G16 RNAAS	G 3/8"	35	23	21	10	-	-	0,05
HK TSD G16 ROAAA	G 3/8"	35	23	21	10	200 mm	OIL	0,05
HK TSD G20 RNAAS	G 1/2"	39	27	21	11	-	-	0,05
HK TSD G20 ROAAS	G 1/2"	39	27	21	11	-	OIL	0,05
HK TSD G20 RNAA 200	G 1/2"	39	27	21	11	210 mm	-	0,06
HK TSD G26 ROAAA	G 3/4"	45	33	21	12	200 mm	OIL	0,07
HK TSD G26 ROAAS	G 3/4"	45	33	21	12	-	OIL	0,05
HK TSD G33 RNAAS	G 1"	51	39	24	13	-	-	0,05
HK TSD G33 ROAAS	G 1"	51	39	24	13	-	OIL	0,05

Web: <http://cat.hansa-flex.com/en/HKTSDG>

HK LVA

Visual fill level indicator

Tightening torque max.: 8 N-m
Temp. max.: 100 °C
Operating pressure: max. 1 bar
Media: Mineral oils
Material: Polyamide, Gasket: NBR
Scope of supply: with hollow screws



Identification	Design	Thread mounting	L mm	Weight kg
HK LVA 10 T M10	with thermometer	2 x M10	76	0,12
HK LVA 10 T M12	with thermometer	2 x M12	76	0,12
HK LVA 20 T M12	with thermometer	2 x M12	127	0,16
HK LVA 30 T M12	with thermometer	2 x M12	254	0,22

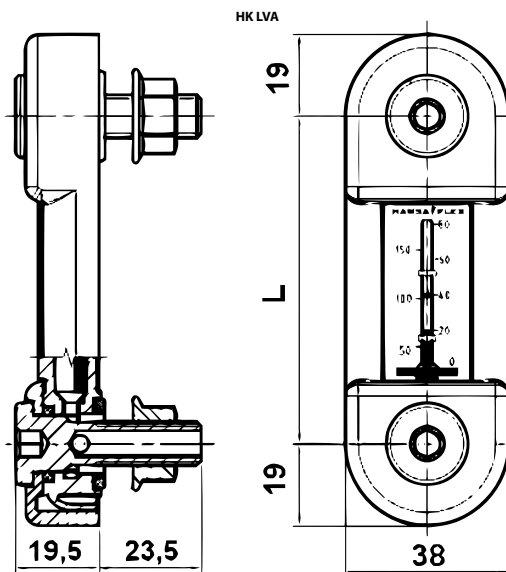

Web: <http://cat.hansa-flex.com/en/HKLVA>

Accessory for following products:

HK BAK RA - BAKRA hydraulic tank
HK BEK - BEK hydraulic tank (without cleaning hatch)
HK BSK - BSK hydraulic tank (with cleaning hatch)

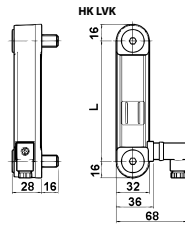
HK LVK**Optical/electrical fill level indicator with temperature switch**

Tightening torque max.: 10 N-m
Operating voltage: max. 230V AC
Temp. max.: 80 °C
Operating pressure: max. 1 bar
Media: Mineral oils
Material: Polyamide, Gasket: NBR
Scope of supply: with hollow screws

Identification	Thread mounting	L mm	Switching function	Switching point °C	Weight kg
HK LVK 10A M12 1T7 P1	2 x M12	76	NC contact	70	0,16
HK LVK 20A M12 1T7 P1	2 x M12	127	NC contact	70	0,18
HK LVK 30A M12 1T7 P1	2 x M12	254	NC contact	70	0,22

Web: <http://cat.hansa-flex.com/en/HKLVK>

Accessory for following products:

HK BAK RA - BAKRA hydraulic tank

HK BEK - BEK hydraulic tank (without cleaning hatch)

HK BSK - BSK hydraulic tank (with cleaning hatch)

HK LCPG

Oil sight glass

Design: Suitable only for mineral oil
Temp. max.: 80 °C
Material: TROGAMID®, Gasket: NBR



Note: Other materials and designs on request

Identification	Thread	A mm	Design	B mm	Ø D mm	AF mm	Weight kg
HK LCPG 13 TSA	G 1/4"	5	without screen	7	19	15	0,01
HK LCPG 16 TSA	G 3/8"	5	without screen	8	21	17	0,01
HK LCPG 20 TSA	G 1/2"	5	without screen	8	27	21	0,01
HK LCPG 26 TSA	G 3/4"	6	without screen	9	33	26	0,02
HK LCPG 26 TCA	G 3/4"	6	with screen	9	33	26	0,02
HK LCPG 33 TCA	G 1"	7	with screen	10	40	32	0,03

AF = Width across flats

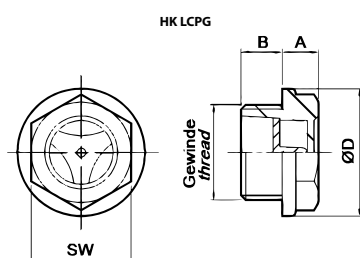

Web: <http://cat.hansa-flex.com/en/HKLCPG>

HK TLA

Oil sight glass

Design: Suitable only for mineral oil
Temp. max.: 100 °C
Material: Aluminium

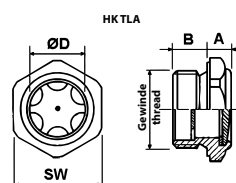

Identification	Thread	A mm	B mm	Ø D mm	AF mm	Weight kg
HK TLA 1 G14	G 1/4"	7	8	10	17	0,05
HK TLA 2 G38	G 3/8"	7	9	13	22	0,01
HK TLA 3 G12	G 1/2"	10	10	16	27	0,01
HK TLA 4 G34	G 3/4"	11	11	21	32	0,02
HK TLA 5 G1	G 1"	14	14	27	40	0,03
HK TLA 6 G114	G 1.1/4"	15	15	37	50	0,05
HK TLA 7 G112	G 1.1/2"	15	15	40	55	0,06
HK TLA 8 G2	G 2"	17	17	50	70	0,11
HK TLA 1 M1415	M 14 x 1.5	7	8	10	17	0,05
HK TLA 2 M1615	M 16 x 1.5	7	9	13	22	0,01
HK TLA 3 M1815	M 18 x 1.5	7	9	13	22	0,01
HK TLA 4 M2015	M 20 x 1.5	7	10	16	24	0,02
HK TLA 5 M2215	M 22 x 1.5	9	10	16	27	0,02
HK TLA 6 M2415	M 24 x 1.5	9	11	16	30	0,02
HK TLA 7 M2420	M 24 x 2	9	11	16	30	0,02
HK TLA 8 M2515	M 25 x 1.5	9	11	21	32	0,02
HK TLA 9 M2715	M 27 x 1.5	9	11	21	32	0,03
HK TLA 10 M3015	M 30 x 1.5	9	11	21	36	0,05
HK TLA 11 M3020	M 30 x 2	9	11	21	36	0,05
HK TLA 12 M3315	M 33 x 1.5	10	14	27	40	0,06
HK TLA 13 M3320	M 33 x 2	10	14	27	40	0,06

AF = Width across flats

Web: <http://cat.hansa-flex.com/en/HKTLA>

HK EH 1460

Screw-in tubular heaters

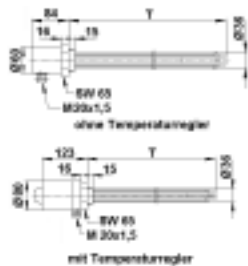

For horizontal installation under the oil surface
 Surface load 1.5 W/cm² for hydraulic oils
 Glossy galvanised steel cover

Design: with or without temperature controller
Connection: G 1 1/2"
Use: for preheating of hydraulic oil

Identification	Heating capacity	Immersion depth	Protection class	Voltage	Temp. control	Weight
	W					
HK EH 1460 650 TA 3X4	1460	650	IP 54	3 x 400 V	external	1,9
HK EH 1460 650 3X4	1460	650	IP 65	3 x 400 V	without	1,7

Web: <http://cat.hansa-flex.com/en/HKEH1460>

HK TEHM

Built-in heating with fixing magnets

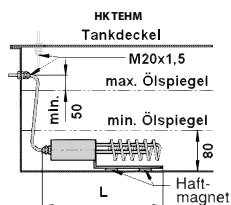

For horizontal or vertical installation below the oil surface
 Simple retrofitting in existing tanks, no draining of the oil necessary
 Switching precision $\pm 3\%$
 Surface load 1.2 W/cm² for hydraulic oils

Design: internal temperature controller (preset at 20°C)
Scope of supply: incl. connection cable 3-pole and cable entry M20x1.5
Use: for preheating of hydraulic oil

Identification	Heating capacity	Immersion depth	L	Voltage	Weight
	W				
HK TEHM 1000	1000	1000	380	230 V	1,65

Web: <http://cat.hansa-flex.com/en/HKTEHM>

MAP pressure switch

Piston pressure switch

Repetition accuracy less than or equal to 1% of set value
 Electric switching rate min. 1 million operating cycles
 Switching hysteresis approx. 2.5 to 10%, depending on pressure range
 Setting via scale
 Universal connection possibilities by separate adapters/connection plates

Design: changeover contact
Operating pressure: max. 630 bar
Connection: 4-hole Flange 31x31 mm
Current consumption: max. 2 A at 250 VAC; max. 3 A at 30 VDC
Material: Steel
Scope of supply: complete with plug, incl. set of screws
protection class: IP 65

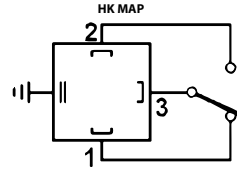

Ordering information: Please order adapters and mounting plates separately!

Identification	Pressure setting range min.		Pressure setting range max.		Weight kg
	bar		bar		
HK MAP 040	5		40		0,5
HK MAP 080	4		80		0,5
HK MAP 160	8		160		0,5
HK MAP 320	40		320		0,5
HK MAP 630	50		630		0,5

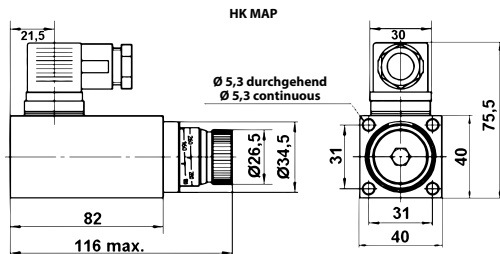

Web: <http://cat.hansa-flex.com/en/HKMAP>

Accessories:

HK BFM - BFM adapter for MAP pressure switch
 HK BHF AG - BHF AG adapter for MAP pressure switch
 HK BHF IG - BHF IG adapter for MAP pressure switch
 HK BHM - BHM mounting plate for MAP pressure switch
 HK BKM - BKM mounting plate for MAP pressure switch
 HK BMM - BMM adapter for MAP pressure switch

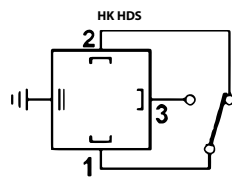
HK HDS
HDS pressure switches

Piston pressure switch

Switch-back difference 8-30 bar

Design: changeover contact
Operating pressure: max. 350 bar
Connection: G 1/4" male, rotatable
Current consumption: max. 4 A at 250 VAC / 28VDC
Material: Steel
Scope of supply: complete with plug
protection class: IP 65

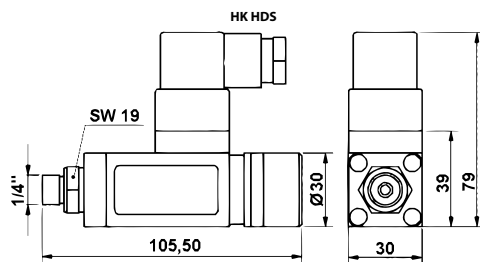
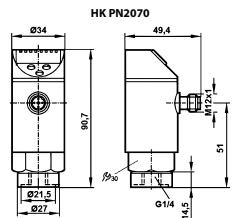
Identification	Pressure setting range min.		Pressure setting range max.		Weight kg
	bar		bar		
HK HDS 1 120 K71	10		120		0,3
HK HDS 1 200 K71	20		200		0,3
HK HDS 1 320 K71	30		320		0,3

Web: <http://cat.hansa-flex.com/en/HKHDS>
HK PN2070
Pressure sensor controller PN2070

Compact unit comprising pressure switch, pressure sensor and LED indicator
 2-color display red / green for visualizing the process status
 3-key operation according to VDMA Standard
 Output: 2x PNP (freely programmable, NC/NO, window/hysteresis)
 1 output can be set as an analogue output (0-10 V / 4-20 mA, scalable 1:4)
 IO-link interface
 Accuracy $\pm 0.5\%$ of range limit value
 Min./max. value memory

Operating temperature max.: 80 °C
Connection: G 1/4" female, rotatable
Operating voltage: 24 V DC
Electrical connection: Round plug connector M 12 x 1, 4-pol.
Material: Housing: Stainless steel V2A, Parts in contact with media: Stainless steel V2A
Scope of supply: without plug
protection class: IP 65

Identification	Measuring range	Weight
		kg
HK PN2070 PN400 SER	0 to 400 bar	0,3

Web: <http://cat.hansa-flex.com/en/HKPN2070>
Accessories:

HK DSR 4POL - M12 4-pin angle plug with cable

HK PT77

Pressure sensor regulator PT77

Compact unit comprising pressure switch, pressure sensor and LED indicator
 Housing can be rotated to 270°
 Output: 2x PNP (freely programmable, NC/NO, window/hysteresis)
 Without analog output
 Accuracy $\pm 0.5\%$ of range limit value
 Min./max. value memory

Design: suitable for DIN rail mounting 35x7.5
Operating temperature max.: 70 °C
Connection: G 1/4" male, rotatable
Operating voltage: 24 V DC
Electrical connection: Round plug connector M 12 x 1, 4-pol.
Material: Housing: Plastic, Parts in contact with media: Stainless steel V2A, Gasket: NBR
Scope of supply: without plug
protection class: IP 65

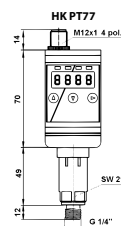

Ordering information: Order M12 plug with cable separately

Identification	Measuring range	Weight kg
HK PT77 1 250 2S	0 to 250 bar	0,5
HK PT77 1 600 2S	0 to 600 bar	0,5

Web: <http://cat.hansa-flex.com/en/HKPT77>

Accessories:

HK DSR 4POL - M12 4-pin angle plug with cable

HK DSR

Pressure sensor controller DSR

Compact unit comprising pressure switch, pressure sensor and LED indicator
 Housing can be rotated to 290°
 Output: 2x PNP (freely programmable, NC/NO, window/hysteresis)
 Without analog output
 Accuracy $\pm 0.5\%$ of range limit value
 Min./max. value memory

Operating temperature max.: 85 °C
Connection: G 1/4" male, rotatable
Operating voltage: 24 V DC
Electrical connection: Round plug connector M 12 x 1, 4-pol.
Material: Housing: Zinc die cast, Parts in contact with media: Stainless steel V2A, Gasket: NBR
Scope of supply: without plug
protection class: IP 67



Ordering information: Order M12 plug with cable separately

Identification	Measuring range	Weight kg
HK DSR 400 04 17	0 to 400 bar	0,3

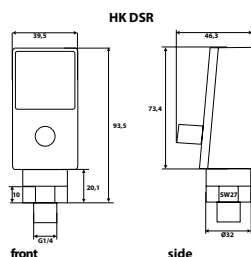

Web: <http://cat.hansa-flex.com/en/HKDSCR>

Accessories:

HK DSR 4POL - M12 4-pin angle plug with cable

HK PG24

Pressure sensor with analogue and digital display

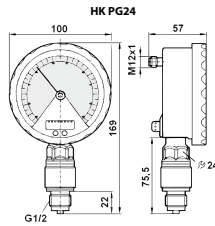

Electronic pressure sensor with analogue and 4-digit digital display
 Housing can be rotated to 350°
 1x switch output (can be programmed as NO or NC contact)
 1x analogue output 4 to 20/20 to 4 mA
 Switching point adjustment range 2 - 400 bar (in increments of 1 bar)
 Accuracy ±0.6 % of range limit value
Operating temperature max.: 80 °C
Connection: G 1/4" male, rotatable
Operating voltage: 24 V DC
Electrical connection: Round plug connector M 12 x 1, 4-pol.
Current consumption: < 70 mA at 24 V
Material: Stainless steel housing, Parts in contact with media: Stainless steel V2A, Gasket: NBR without plug
Scope of supply: protection class: IP 67

Note: Indicator is not visible when the power is disconnected

Ordering information: Order M12 plug with cable separately

Identification	Measuring range	Weight kg
HK PG24 50 G12 400	0 to 400 bar	0,6

Web: <http://cat.hansa-flex.com/en/HKPG24>

Accessories:

HK DSR 4POL - M12 4-pin angle plug with cable

HK BHF IG

BHF IG adapter for MAP pressure switch



Connection: G 1/4" female thread
Material: Steel
Use: for mounting of pressure switches with mit 4-hole Flange 31x31 mm

Identification	Weight kg
HK BHF IG 14	0,35

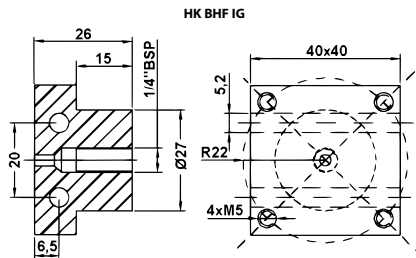

Web: <http://cat.hansa-flex.com/en/HKBHF IG>

Accessory for following products:

HK MAP - MAP pressure switch

HK BHF AG

BHF AG adapter for MAP pressure switch

Connection: G 1/4" male thread
Material: Steel
Use: for mounting of pressure switches with mit 4-hole Flange 31x31 mm



Identification

HK BHF AG 14

Weight

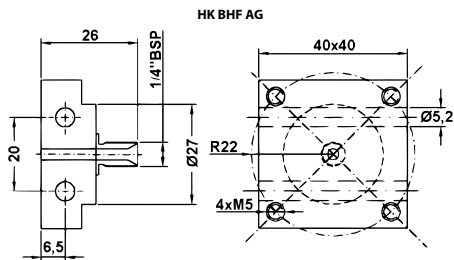
kg
0,35

Web: <http://cat.hansa-flex.com/en/HKBHFAG>

Accessory for following products:

HK MAP - MAP pressure switch

HK BMM

BMM adapter for MAP pressure switch

Connection: G 3/8" male thread
Material: Steel
Use: for mounting of pressure switches with mit 4-hole Flange 31x31 mm



Identification

HK BMM 10

Weight

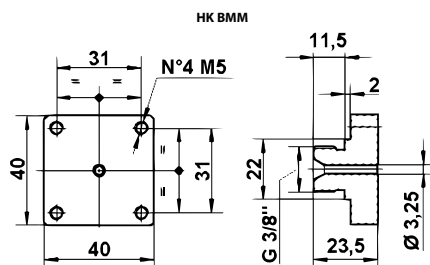
kg
0,3

Web: <http://cat.hansa-flex.com/en/HKBMM>

Accessory for following products:

HK MAP - MAP pressure switch

HK BFM**BFM adapter for MAP pressure switch**

Connection: G 3/8" female thread
Material: Steel
Use: for mounting of pressure switches with mit 4-hole Flange 31x31 mm

Identification

HK BFM 10

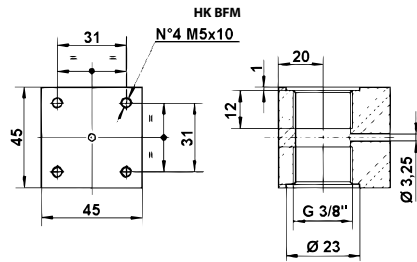
Weightkg
0,7

Web: <http://cat.hansa-flex.com/en/HKBFM>

Accessory for following products:

HK MAP - MAP pressure switch

BHM mounting plate for MAP pressure switch

Connection: ISO/Cetop 03 size 6
Material: Steel
Use: for mounting of pressure switches with mit 4-hole Flange 31x31 mm



1

Identification	Measuring channel	Weight kg
HK BHM 03 P	P	1,2
HK BHM 03 A+B	A+B	1,2
HK BHM 03 A	A	1,2
HK BHM 03 B	B	1,2

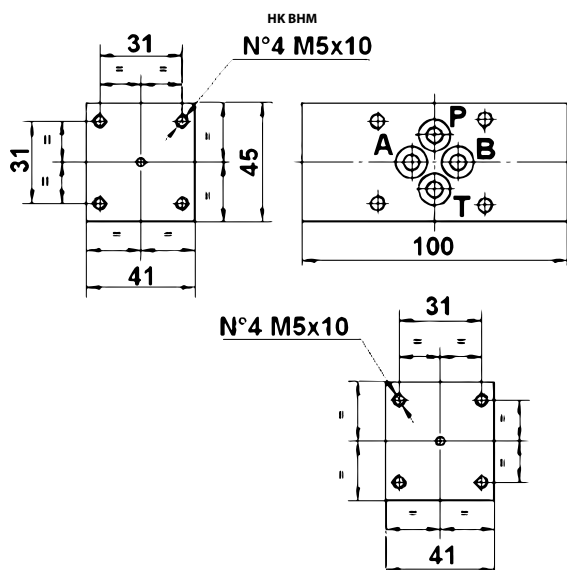

Web: <http://cat.hansa-flex.com/en/HKBHM>

Accessory for following products:
 HK MAP - MAP pressure switch

HK BKM

BKM mounting plate for MAP pressure switch



Connection: ISO/Cetop 05 size 10
Material: Steel
Use: for mounting of pressure switches with mit 4-hole Flange 31x31 mm

1

Identification	Measuring channel	Weight kg
HK BKM 05 P	P	2,0
HK BKM 05 A+B	A+B	2,0
HK BKM 05 A	A	2,0
HK BKM 05 B	B	2,0

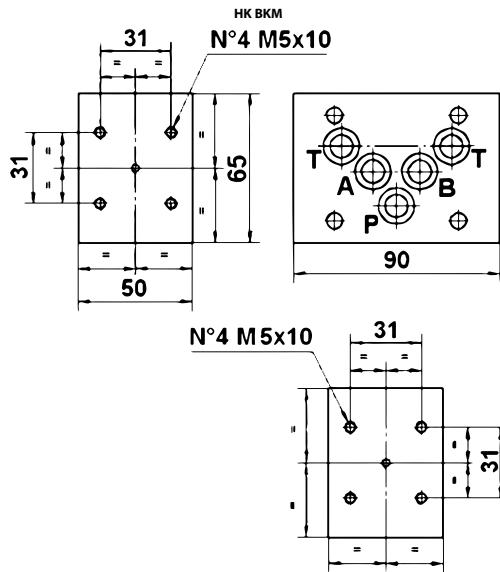

Web: <http://cat.hansa-flex.com/en/HKBKM>

Accessory for following products:
 HK MAP - MAP pressure switch

HK DSR 4POL

M12 4-pin angle plug with cable

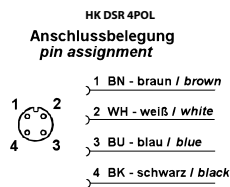

Scope of supply: with cable 5.0m

Identification	Weight kg
HK DSR M12 4POL 5.0 W	0,2

Web: <http://cat.hansa-flex.com/en/HKDSR4POL>

HK 64EJ

Level/temperature switch HK 64EJ

Freely combinable kit for level and temperature switches
 Cable-free, adjustable level contact
 Can be installed as NO or NC contact
 Simple retrofitting for temperature monitoring
 Bistable = only one float switch with high float dynamics
 Maintenance-free
 Density of fluid min. 0.8 kg/dm³

Operating pressure: max. 1 bar
Operating temperature max.: 80 °C
Connection: bolt hole Ø 73 mm
Electrical connection: Device connector S6 DIN EN 175201-804
Material: Float SK 601 - hard PU, Switching tube - brass, Flange - PA
Scope of supply: incl. seal and screw set, incl. connector

**Note:** Basic unit comprises:

Level switch for tank installation with float and S6 plug

1x adjustable level contact K101-green, installed as NC contact

Installation and assembly must be carried out by qualified staff.

Level contacts or temperature sensors must be connected to the contact plate clean and free of oil.

For the proper function of the temperature sensors it is important that they have contact to the bottom of the dip tube without air gap. Make sure that the contact plate is inserted completely and fixed in the dip tube.

Identification	L mm	Weight kg
HK 64EJ K101 S6 250	250	0,3
HK 64EJ K101 S6 370	370	0,3
HK 64EJ K101 S6 520	520	0,4

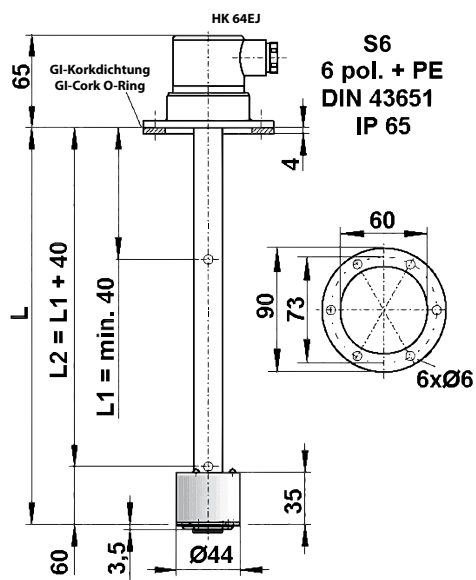

Web: <http://cat.hansa-flex.com/en/HK64EJ>

Accessories:

HK LK EJ - Level contact for level/temperature switch

HK TKO / TKS - Temperature contact for level/temperature switch

HK KL EJ - Resistance thermometer for level/temperature switch

HK THERMO EJ - Temperature transmitter for level/temperature switch

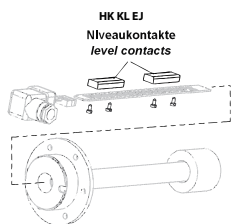
HK LK E J**Level contact for level/temperature switch**

For mounting on contact strip of level-temperature switch HK64EJ
Level contacts can be installed as NC or NO contacts (turn by 180° during installation)

Use different colours when using 2 or 3 contacts

Contact distance min.: 40 mm

Contact load max.: 10 VA

Switching current max.: 0,5 A

Use: for Level-Temperature Switches HK 64EJ

Note: Installation and assembly must be carried out by qualified staff.

Level contacts or temperature sensors must be connected to the contact plate clean and free of oil.

Identification	Colour	Voltage	Weight kg
HK L1 K101 EJ	green	max. 24 V	0,01
HK L2 K102 EJ	yellow	max. 24 V	0,01
HK L3 K103 EJ	red	max. 24 V	0,01

Web: <http://cat.hansa-flex.com/en/HKLKEJ>

Accessory for following products:

HK 64EJ - Level/temperature switch HK 64EJ

Level/temperature switch HK NTM

One permanently set switching point (NC contact) for level and temperature

Operating pressure: max. 1 bar

Operating temperature max.: 80 °C

Connection: G 3/4" male

Operating voltage: max. 230V AC

Electrical connection: Device connector M3 (3-polig)

Protection IP: IP 65

Material: Float SK 601 - hard PU, Switching tube - brass, Gasket: NBR

Hysteresis: ± 5 K



Identification	L mm	Switching point		Weight kg
		°C	mm	
HK NTM M3 140 60NC 280	280	60	140	0,30
HK NTM M3 140 70NC 280	280	70	140	0,30
HK NTM M3 140 80NC 280	280	80	140	0,30
HK NTM M3 190 60NC 280	280	60	190	0,30
HK NTM M3 190 70NC 280	280	70	190	0,30
HK NTM M3 190 80NC 280	280	80	190	0,30
HK NTM M3 320 60NC 370	370	60	320	0,40
HK NTM M3 320 70NC 370	370	70	320	0,40
HK NTM M3 320 80NC 370	370	80	320	0,40

Switching point (°C) = temperature switching point Switching point (mm) = level switching point

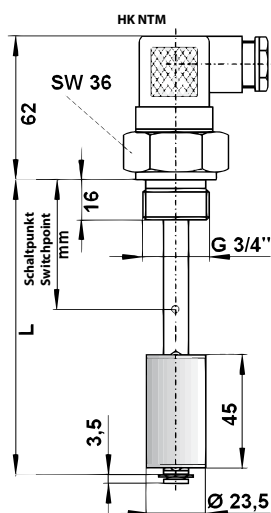

Web: <http://cat.hansa-flex.com/en/HKNTM>

HK NTM XP**Level/temperature switch with LED display HK NTMXP**

Housing can be rotated to 270°
 Output: 2x PNP (freely programmable, NC/NO, window/hysteresis)
 Min./max. value memory
 Level measurement: Sensor length 45 mm, display resolution 10 mm
 Temperature measurement: -20 °C to +120 °C (PT100)
 Accuracy ±1 % of range limit value

Operating pressure: max. 1 bar
Operating temperature max.: 70 °C
Connection: G 3/4" male
Operating voltage: 24 V DC
Electrical connection: M12x1, 4-polig
Protection IP: IP 65
Material: Float SK 601 - hard PU, Switching tube - brass, Gasket: NBR
Scope of supply: without plug

Ordering information: Order M12 plug with cable separately

Identification	L mm	Weight kg
HK NTM XP MS 2S 280	280	0,39
HK NTM XP MS 2S 370	370	0,41
HK NTM XP MS 2S 500	500	0,43

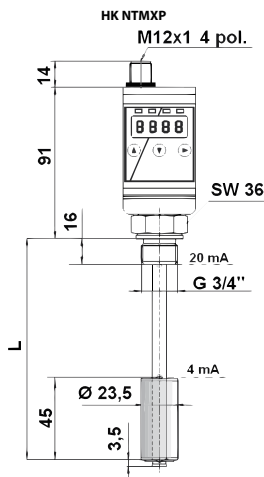

Web: <http://cat.hansa-flex.com/en/HKNTMXP>

Accessories:

HK DSR 4POL - M12 4-pin angle plug with cable

HK PAN

Level/temperature switch HK PAN

Housing can be rotated to 350°
 Output: 2x high-side per parameter (freely programmable, NC/NO, window/hysteresis)
 Level measurement: Sensor length 35 mm, display resolution 5 mm
 Temperature measurement: -15°C to +100°C (PT100)
 Accuracy ±1 % of range limit value
Operating pressure: max. 1 bar
Operating temperature max.: 70 °C
Connection: G 1/2" male
Operating voltage: 24 V DC
Electrical connection: M12x1, 8-polig
Protection IP: IP 65
Material: Gasket: NBR
Scope of supply: without plug



Ordering information: Order M12 plug with cable separately

Identification	L mm	Weight kg
HK PAN 1 1001	250	1,0
HK PAN 1 1002	370	1,0
HK PAN 1 1003	520	1,0

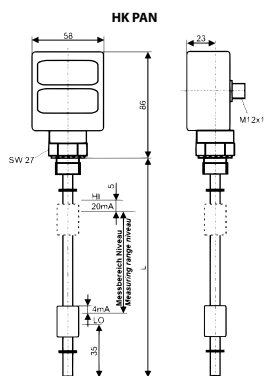

Web: <http://cat.hansa-flex.com/en/HK PAN>

Accessories:
 HK PAN M - M12 8-pin plug with cable

HK PAN M

M12 8-pin plug with cable

Design: Cable connector for sensors with M12 port
Material: TPU, Brass
Scope of supply: with cable 5.0m

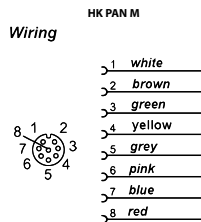

Identification	Type	Weight kg
HK PAN M12 8POL 5.0 G	Linear plug	1,0
HK PAN M12 8POL 5.0 W	Angled plug 90°	1,0

Web: <http://cat.hansa-flex.com/en/HK PAN M>

HK TS

TS temperature switch

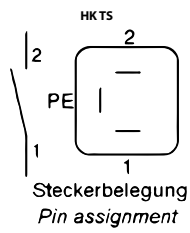

Design: 1 temperature contact, incl. seal
Operating pressure: max. 1 bar
Operating temperature max.: 80 °C
Current consumption: max. 1 A at 250 VAC
Hysteresis: 10 K ± 5 K
Scope of supply: incl. connector

1

Identification	Switching temperature °C	Switching function	Weight kg
HK TS 50 NC-12	50	NC contact	0,31
HK TS 60 NC-12	60	NC contact	0,31
HK TS 70 NC-12	70	NC contact	0,31
HK TS 80 NC-12	80	NC contact	0,31
HK TS 50 NO-12	50	NO contact	0,31
HK TS 60 NO-12	60	NO contact	0,31
HK TS 70 NO-12	70	NO contact	0,31
HK TS 80 NO-12	80	NO contact	0,31

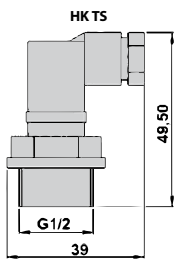

Web: <http://cat.hansa-flex.com/en/HKTS>

HK TSK1

TSK1 temperature switch

Design:	Bi-metal switching element, 1 temperature contact
Operating pressure:	max. 1 bar
Operating temperature max.:	80 °C
Operating voltage:	max. 230V AC
Electrical connection:	Device connector M3 (3-polig)
Material:	Switching tube - brass, Gasket: NBR
Hysteresis:	10 K ± 5 K
Scope of supply:	incl. connector



Identification	Switching point °C	Switching function	L mm	Weight kg
HK TSK1 TKO50 L340	50	NC contact	340	0,5
HK TSK1 TKO60 L340	60	NC contact	340	0,5
HK TSK1 TKO70 L340	70	NC contact	340	0,5
HK TSK1 TKO80 L340	80	NC contact	340	0,5

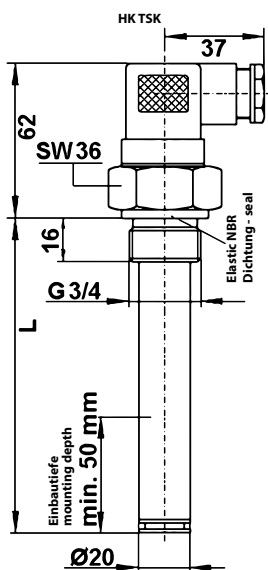

Web: <http://cat.hansa-flex.com/en/HKTSK1>

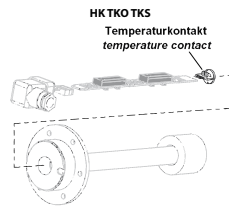
HK TKO / TKS**Temperature contact for level/temperature switch**

For mounting on contact strip of level-temperature switch HK64EJ

Contact load max.: 24 VA
Switching current max.: 1,0 A
Hysteresis: 10 K ± 3 K
Use: for Level-Temperature Switches HK 64EJ

Note: Installation and assembly must be carried out by qualified staff.

Level contacts or temperature sensors must be connected to the contact plate clean and free of oil.

For the proper function of the temperature sensors it is important that they have contact to the bottom of the dip tube without air gap. Make sure that the contact plate is inserted completely and fixed in the dip tube.

Identification	Switching point °C	Voltage	Switching function	Weight kg
HK TKO 50 RD EJ	50	24 V	NC contact	0,01
HK TKO 60 RD EJ	60	24 V	NC contact	0,01
HK TKO 70 RD EJ	70	24 V	NC contact	0,01
HK TKO 80 RD EJ	80	24 V	NC contact	0,01
HK TKS 50 RD EJ	50	24 V	NO contact	0,01
HK TKS 60 RD EJ	60	24 V	NO contact	0,01
HK TKS 70 RD EJ	70	24 V	NO contact	0,01
HK TKS 80 RD EJ	80	24 V	NO contact	0,01

Web: <http://cat.hansa-flex.com/en/HKTKOTKS>

Accessory for following products:

HK 64EJ - Level/temperature switch HK 64EJ

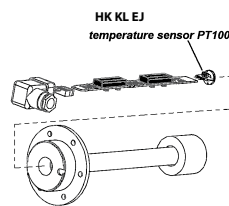
HK KL EJ**Resistance thermometer for level/temperature switch**

For mounting on contact strip of level-temperature switch HK64EJ

Design: resistance thermometers PT 100 (Tol. ±0,8°C)
Operating voltage: 24 V DC
Use: for Level-Temperature Switches HK 64EJ

Note: Installation and assembly must be carried out by qualified staff.

Level contacts or temperature sensors must be connected to the contact plate clean and free of oil.

For the proper function of the temperature sensors it is important that they have contact to the bottom of the dip tube without air gap. Make sure that the contact plate is inserted completely and fixed in the dip tube.

Identification	Weight kg
HK KL PT100 EJ	0,2

Web: <http://cat.hansa-flex.com/en/HKKLEJ>

Accessory for following products:

HK 64EJ - Level/temperature switch HK 64EJ

HK THERMO EJ

Temperature transmitter for level/temperature switch

Output signal 4 to 20 mA

For mounting on contact strip of level-temperature switch HK64EJ

Design: temperature transmitter with PT 100

Operating voltage: 24 V DC

Use: for Level-Temperature Switches HK 64EJ

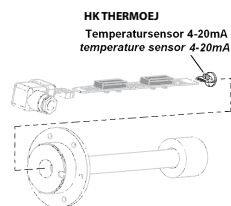

Note: Installation and assembly must be carried out by qualified staff.

Level contacts or temperature sensors must be connected to the contact plate clean and free of oil.

For the proper function of the temperature sensors it is important that they have contact to the bottom of the dip tube without air gap. Make sure that the contact plate is inserted completely and fixed in the dip tube.

Identification	Weight
HK THERMOLOG 4EJ	kg 0,2

Web: <http://cat.hansa-flex.com/en/HKTHERMOEJ>

Accessory for following products:

HK 64EJ - Level/temperature switch HK 64EJ

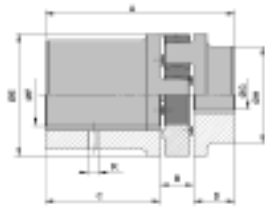
HK SPIDEX Z
Spidex coupling for gear pumps

torsionally flexible, vibration damping, maintenance-free

Design: combinable with pump mount HK PT
Material: Aluminium
Use: For gear pumps size 0 to size 3

Identification	A mm	B mm	C mm	D mm	K	Ø E mm	Ø F mm	Ø G mm	Ø H mm	Motor	Pump	Weight kg
HK A1914 714 184 AL	55,00	16	25,0	14,0	M5	40	14	7,00	32	BG71	BG0/cyl. shaft	0,12
HK A1914 N1 AL	58,00	16	25,0	17,0	M5	40	14	9,75	32	BG71	BG1/shaft 1:8	0,12
HK A1919 714 184 AL	55,00	16	25,0	14,0	M5	40	19	7,00	32	BG80	BG0/cyl. shaft	0,16
HK A1919 N1 AL	58,00	16	25,0	17,0	M5	40	19	9,75	32	BG80	BG1/shaft 1:8	0,16
HK A2419 N2A AL	72,00	16	30,0	24,0	M5	55	19	17,28	40	BG80	BG2/shaft 1:8	0,34
HK A2419 7 B17 AL	66,50	18	30,0	18,5	M5	55	19	17,40	40	BG80	BG2 / shaft 1:5	0,25
HK A1924 24 N1 AL	58,00	16	25,0	17,0	M5	40	24	9,75	32	BG90	BG1/shaft 1:8	0,34
HK A2424 N2A AL	72,00	18	30,0	24,0	M5	55	24	17,28	40	BG90	BG2/shaft 1:8	0,34
HK A2424 7 B17 AL	6,50	18	30,0	18,5	M5	55	24	17,40	40	BG90	BG2 / shaft 1:5	0,25
HK A2432 28 60 N1 AL	95,00	18	60,0	17,0	M5	55	28	9,75	40	BG100/112	BG1/shaft 1:8	0,45
HK A2432 28 N2A AL	72,00	18	30,0	24,0	M5	55	28	17,28	52	BG100/112	BG2/shaft 1:8	0,45
HK A2432 28 7 B17 AL	66,50	18	30,0	18,5	M5	55	28	17,40	40	BG100/112	BG2 / shaft 1:5	0,27
HK A2432 28 N3 AL	76,00	18	30,0	28,0	M5	55	28	22,00	52	BG100/112	BG3/shaft 1:8	0,45
HK A2838 38 60 N2A AL	104,00	20	60,0	24,0	M6	65	38	17,28	48	BG132	BG2/shaft 1:8	0,90
HK A2838 38 7 B17 AL	73,50	20	35,0	18,5	M6	65	38	17,40	48	BG132	BG2 / shaft 1:5	0,30
HK A2838 38 60 N3 AL	108,00	20	60,0	28,0	M6	65	38	22,00	62	BG132	BG3/shaft 1:8	0,95
HK A3845 42 N2A AL	93,00	24	45,0	24,0	M8	80	42	17,28	77	BG160	BG2/shaft 1:8	1,60
HK A3845 42 7 B17 AL	112,50	24	70,0	18,5	M8	80	38	17,40	66	BG160	BG2 / shaft 1:5	0,68
HK A3845 42 N3 AL	97,00	24	45,0	28,0	M8	80	42	22,00	77	BG160	BG3/shaft 1:8	1,60

Web: <http://cat.hansa-flex.com/en/HKSPIDEXZ>

Spare parts:

HK ZK - Sprocket for coupling

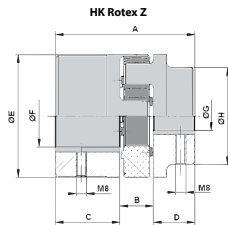
HK ROTEX Z
Rotex coupling for gear pumps

torsionally flexible, vibration damping, maintenance-free

Axial connection, fail-safe

Compact construction, low moments of inertia

Design: combinable with pump mount HK HL/PL
Material: Steel
Use: For gear pumps size 2 and size 3

Identification	A mm	B mm	C mm	D mm	Ø E mm	Ø F mm	Ø G mm	Ø H mm	Motor	Pump	Weight kg
HK R 28 38 N2A	79	20	35	24	65	38	17,29	35	BG132	BG2/shaft 1:8	1,18
HK R 38 42 N2A	93	24	45	24	80	42	17,29	35	BG160	BG2/shaft 1:8	1,18
HK R 28 38 N3	83	20	35	28	65	38	22,00	48	BG132	BG3/shaft 1:8	1,18
HK R 38 42 N3	97	24	45	28	80	42	22,00	48	BG160	BG3/shaft 1:8	2,06
HK R 42 48 N3	104	26	50	28	95	48	22,00	48	BG180	BG3/shaft 1:8	3,30

Web: <http://cat.hansa-flex.com/en/HKROTEXZ>

HK ROTEX AF
Rotex coupling for axial piston and vane pumps

torsionally flexible, vibration damping, maintenance-free

Axial connection, fail-safe

Compact construction, low moments of inertia

Design: combinable with pump mount HK PK

Material: GG

Use: For axial piston pump HK PVPC and vane pump HK PFE

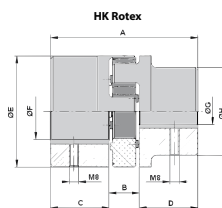

Identification	A mm	B mm	C mm	D mm	Ø E mm	Ø F mm	Ø G mm	Ø H mm	Groove width on pump end mm	Motor	Pump	Weight kg
HK R 3842-22.22 G	114	24	45	45	80	42	22,22	66	4,75	BG160	HKPFE41	2,5
HK R 3842-22.22 F	114	24	45	45	80	42	22,22	66	6,38	BG160	HKPVPC30	2,5
HK R 3842-25.38 BS	114	24	45	45	80	42	25,38	66	6,37	BG160	HKPVPC40	2,5
HK R 4248-22.22 G	126	26	50	50	95	48	22,22	75	4,75	BG180	HKPFE41	3,9
HK R 4248-34.92 M	126	26	50	50	95	48	34,92	75	7,93	BG180	HKPFE52	3,9
HK R 4248-22.22 F	126	26	50	50	95	48	22,22	75	6,38	BG180	HKPVPC30	3,9
HK R 4248 75-25 38 BS	151	26	75	50	95	48	25,38	75	6,37	BG160/180	HKPVPC40	4,5
HK R 4248-31.75 K	126	26	50	50	95	48	31,75	75	7,93	BG180	HKPVPC50	3,9
HK R 4255-34.92 M	126	26	50	50	95	55	34,92	75	7,93	BG200	HKPFE52	3,9
HK R 4255 75-25 38 BS	151	26	75	50	95	55	25,38	75	6,37	BG200	HKPVPC40	4,5
HK R 4255-31.75 K	126	26	50	50	95	55	31,75	75	7,93	BG200	HKPVPC50	3,9
HK R 4860 80-31.75 K	164	28	80	56	105	60	31,75	85	7,93	BG225	HKPVPC50	6,0

Web: <http://cat.hansa-flex.com/en/HKROTEXAF>

HK PT
Pump mount PT

Centring for motor and pump shaft

Design: combinable with coupling HK SPIDEX Z

Material: Aluminium

Use: For gear pumps size 0 to size 3

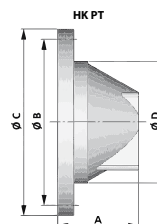

Identification	A mm	Ø B mm	Ø C mm	Ø D mm	Flange for pump connection	Pump	Motor	Weight kg
HK PT RV 160 70 468	70,00	130	160	110	Two-hole flange 66	BG0/cyl. shaft	BG71	0,5
HK PT RV 160 80 448 ZFV	80,00	130	160	110	71.9 x 52.4	BG1/shaft 1:8	BG71	0,5
HK PT RV 200 80 468	80,00	165	200	145	Two-hole flange 66	BG0/cyl. shaft	BG80	0,7
HK PT RV 200 80 448	80,00	165	200	145	71.9 x 52.4	BG1/shaft 1:8	BG80	0,7
HK PT RV 200 90 448	90,00	165	200	145	71.9 x 52.4	BG1/shaft 1:8	BG90	0,7
HK PT RV 200 96 446 ZFV	96,00	165	200	145	96.2 x 71.5	BG2/shaft 1:8	BG80/90	0,7
HK PT RV 200 96 441	96,00	165	200	145	100 x 72 (Ø80)	BG2 / shaft 1:5	BG80/90	0,8
HK PT RV 250 110 448	110,00	215	250	190	71.9 x 52.4	BG1/shaft 1:8	BG100/112	1,3
HK PT RV 250 110 446	110,00	215	250	190	96.2 x 71.5	BG2/shaft 1:8	BG100/112	1,3
HK PT RV 250 110 441	110,00	215	250	190	100 x 72 (Ø80)	BG2 / shaft 1:5	BG100/112	1,2
HK PT RV 250 115 465	115,00	215	250	190	128 x 98	BG3/shaft 1:8	BG100/112	1,2
HK PT RV 300 130 446	130,00	265	300	234	96.2 x 71.5	BG2/shaft 1:8	BG132	2,0
HK PT RV 300 130 441	130,00	265	300	234	100 x 72 (Ø80)	BG2 / shaft 1:5	BG132	1,9
HK PT RV 300 144 465	144,00	265	300	234	128 x 98	BG3/shaft 1:8	BG132	2,0
HK PT RV 350 173 446	173,00	300	350	260	96.2 x 71.5	BG2/shaft 1:8	BG160	3,4
HK PT RV 350 173 441	173,00	300	350	260	100 x 72 (Ø80)	BG2 / shaft 1:5	BG160	2,7
HK PT RV 350 173 465	173,00	300	350	260	128 x 98	BG3/shaft 1:8	BG160/180	3,4

Web: <http://cat.hansa-flex.com/en/HKPT>

Accessories:

HK DRV - Damping ring

HK DPT - Gasket for pump mounts

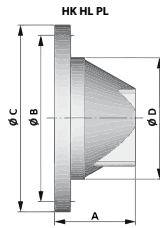
HK HL / PL
HL / PL pump mount

Centring for motor and pump shaft

Design: combinable with coupling HK HE and HK ROTEX Z
Material: Aluminium
Use: For gear pumps size 2 and size 3

Identification	A mm	Ø B mm	Ø C mm	Ø D mm	Flange for pump connection	Pump	Motor	Weight kg
HK PL 300 01 02	135,00	265	300	234	96.2 x 71.5	BG2/shaft 1:8	BG132	1,99
HK PL 300 01 10	135,00	265	300	234	128 x 98	BG3/shaft 1:8	BG132	1,99
HK PL 350 01 05	175,00	300	350	260	96.2 x 71.5	BG2/shaft 1:8	BG160/180	3,38
HK PL 350 01 06	175,00	300	350	260	128 x 98	BG3/shaft 1:8	BG160/180	3,38

Web: <http://cat.hansa-flex.com/en/HKHLPL>

Accessories:

HK DRV - Damping ring

HK DPT - Gasket for pump mounts

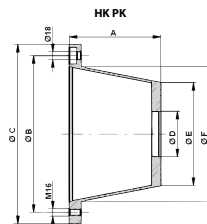
HK PK
Pump carrier PK

Centring for motor and pump shaft

Design: combinable with coupling HK ROTEX AF
Material: Aluminium
Use: For axial piston pump HK PVPC and vane pump HK PFE

Identification	A mm	Ø B mm	Ø C mm	Ø D mm	Ø E mm	Ø F mm	Flange for pump connection	Pump	Motor	Weight kg
HK PK 350 040 400	188,00	300	350	101,6	225	260	Two-hole flange 146	HKPFE41 / HKPVPC30	BG160	2,9
HK PK 350 060 400	204,00	300	350	101,6	230	260	Two-hole flange 146	HKPFE41 / HKPVPC30	BG160/180	3,0
HK PK 350 060 500	204,00	300	350	127,0	230	260	Two-hole flange 181	HKPFE50	BG180	3,0
HK PK 350 101 900	228,00	300	350	127,0	248	260	Two-hole flange 181	HKPFE52	BG180	3,3
HK PK 400 040 400	204,00	350	400	101,6	230	300	Two-hole flange 146	HKPVPC40	BG200	5,3
HK PK 400 040 600	204,00	350	400	127,0	230	300	Two-hole flange 181	HKPVPC50	BG200	5,1
HK PK 400 050 700	228,00	350	400	127,0	279	300	Two-hole flange 181	HKPFE52	BG200	5,7
HK PK 450 032 300	262,00	400	450	127,0	315	350	Two-hole flange 181	HKPVPC50	BG225	6,6

Web: <http://cat.hansa-flex.com/en/HKPK>

Accessories:

HK DRV - Damping ring

HK DPT - Gasket for pump mounts

HK PTF

Foot flange for pump mounts

Design: PTFL - lightweight version, PTFS - heavyweight version
Material: Aluminium



1

Identification	A mm	B mm	C mm	D mm	E mm	H1 mm	H2 mm	R mm	Weight kg
HK PTF L 350	340	195	180	20	150	300	110	150,00	2,0
HK PTF S 400	400	277	260	20	350	350	300	175,00	4,8
HK PTF S 450	450	312	295	25	385	400	335	200,00	5,2

HK PTF

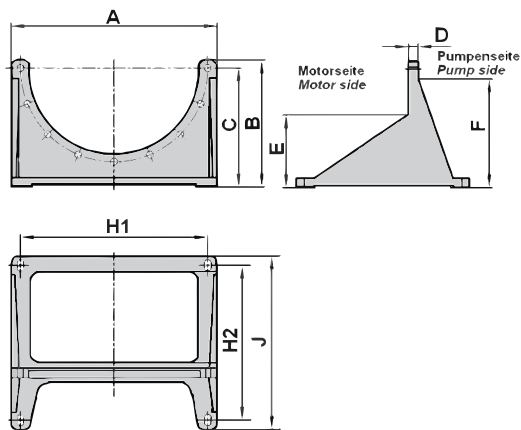

Web: <http://cat.hansa-flex.com/en/HKPTF>

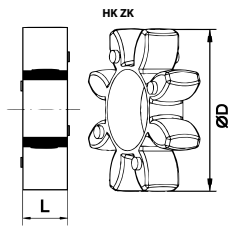
HK ZK
Sprocket for coupling

Material:
Use:

 Polyurethane
 for elastic couplings

Identification	for coupling size	Ø D mm	L mm	Material	Weight kg
HK ZK ROTEX 24	Rotex 24	55,0	16,0	elastomer / PU 98 Shore	0,2
HK ZK SPIDEX 19 92SH	Spidex 19	40,0	12,0	elastomer / PU 92 Shore	0,2
HK ZK SPIDEX 19 98SH	Spidex 19	40,0	12,0	elastomer / PU 98 Shore	0,2
HK ZK SPIDEX 24 92SH	Spidex 24	55,0	14,0	elastomer / PU 92 Shore	0,2
HK ZK SPIDEX 24 98SH	Spidex 24	55,0	14,0	elastomer / PU 98 Shore	0,2
HK ZK SPIDEX 28 92SH	Spidex 28	65,0	15,0	elastomer / PU 92 Shore	0,2
HK ZK SPIDEX 28 98SH	Spidex 28	65,0	15,0	elastomer / PU 98 Shore	0,2
HK ZK SPIDEX 38 92SH	Spidex 38	80,0	18,0	elastomer / PU 92 Shore	0,2
HK ZK SPIDEX 38 98SH	Spidex 38	80,0	18,0	elastomer / PU 98 Shore	0,2
HK ZK SPIDEX 42 92SH	Spidex 42	95,0	20,0	elastomer / PU 92 Shore	0,2
HK ZK SPIDEX 42 98SH	Spidex 42	95,0	20,0	elastomer / PU 98 Shore	0,2
HK ZK SPIDEX 48 92SH	Spidex 48	105,0	21,0	elastomer / PU 92 Shore	0,2
HK ZK SPIDEX 48 98SH	Spidex 48	105,0	21,0	elastomer / PU 98 Shore	0,2
HK ZK SPIDEX 55 92SH	Spidex 55	120,0	22,0	elastomer / PU 92 Shore	0,2
HK ZK SPIDEX 55 98SH	Spidex 55	120,0	22,0	elastomer / PU 98 Shore	0,2
HK ZK SPIDEX 65 92SH	Spidex 65	135,0	26,0	elastomer / PU 92 Shore	0,2
HK ZK SPIDEX 65 95SH	Spidex 65	135,0	26,0	elastomer / PU 95 Shore	0,2
HK ZK SPIDEX 75 92SH	Spidex 75	160,0	30,0	elastomer / PU 92 Shore	0,2
HK ZK SPIDEX 75 95SH	Spidex 75	160,0	30,0	elastomer / PU 95 Shore	0,2
HK ZK SPIDEX 90 92SH	Spidex 90	200,0	34,0	elastomer / PU 92 Shore	0,2
HK ZK SPIDEX 90 95SH	Spidex 90	200,0	34,0	elastomer / PU 95 Shore	0,2
HK ZK SPIDEX 100 92SH	Spidex 100	225,0	39,0	elastomer / PU 92 Shore	0,2
HK ZK SPIDEX 100 95SH	Spidex 100	225,0	39,0	elastomer / PU 95 Shore	0,2

Web: <http://cat.hansa-flex.com/en/HKZK>
Spare part for following products:
HK SPIDEX Z - Spidex coupling for gear pumps

HK ROTEX AF - Rotex coupling for axial piston and vane pumps

HK ROTEX Z - Rotex coupling for gear pumps

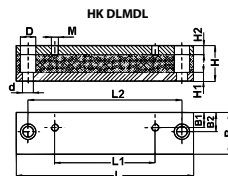
HK DLMDL
DLMDL damping rail

 For noise level reduction and vibration damping
 Damping natural rubber vulcanised with steel rails
 No metal connection between construction and sub-construction

Material:
Use:

 NBR
 for electric motors type IM B35

Identification	IEC motor size	B mm	B1 mm	B2 mm	D mm	d mm	H mm	H1 mm	H2 mm	L mm	L1 mm	L2 mm	M	Weight kg
HK DLMDL 90L	90L	50,00	22,0	25,0	20,0	14,00	40,0	8,00	12	240,0	125,0	205,0	M8	2,10
HK DLMDL 100L	100L	50,00	24,0	25,0	20,0	14,00	40,0	8,00	12	240,0	140,0	205,0	M10	2,25
HK DLMDL 112M	112M	50,00	20,0	25,0	20,0	14,00	40,0	8,00	12	240,0	140,0	205,0	M10	2,30
HK DLMDL 132S	132S	50,00	20,0	25,0	20,0	14,00	45,0	8,00	12	285,0	140,0	245,0	M10	2,42
HK DLMDL 132M	132M	50,00	20,0	25,0	20,0	14,00	45,0	8,00	12	285,0	178,0	245,0	M10	2,42
HK DLMDL 160M	160M	70,00	28,0	35,0	26,0	18,00	60,0	15,00	15	340,0	210,0	300,0	M12	7,50
HK DLMDL 160L	160L	70,00	28,0	35,0	26,0	18,00	60,0	15,00	15	416,0	254,0	370,0	M12	7,50
HK DLMDL 180M	180M	70,00	35,0	35,0	26,0	18,00	60,0	15,00	15	416,0	241,0	370,0	M12	8,00
HK DLMDL 180L	180L	70,00	35,0	35,0	26,0	18,00	60,0	15,00	15	446,0	279,0	400,0	M12	8,00
HK DLMDL 200L	200L	70,00	35,0	35,0	32,0	22,00	60,0	15,00	15	496,0	305,0	430,0	M16	8,55

Web: <http://cat.hansa-flex.com/en/HKDLMDL>

HK DRV
Damping ring

For use between pump mount and tank
 For noise level reduction and vibration damping
 No metal connection between construction and sub-construction
 Vulcanised sealing lip to seal to the tank

Material: NBR

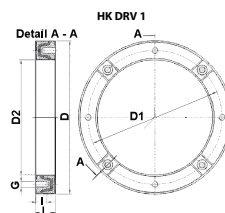

Identification	IEC motor size	Ø D mm	Ø D1 mm	Ø D2 mm	G	I mm	L mm	Weight kg
HK DRV1 250	100L / 112M	250,0	215,0	191,0	4 x M12	22,0	45,0	1,67
HK DRV1 300	132S / 132M	300,0	265,0	235,0	4 x M12	22,0	50,0	2,54
HK DRV1 350	160M/160L 180M/180L	350,0	300,0	261,0	4 x M16	22,0	60,0	5,00
HK DRV1 400	200L	400,0	350,0	301,0	4 x M16	29,0	50,0	7,20

Web: <http://cat.hansa-flex.com/en/HKDRV>

HK DPT
Gasket for pump mounts

For use between pump mount and assembly plate

Seal height: 2 mm

Material: NBR

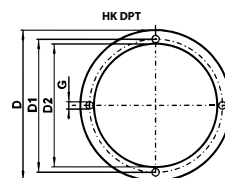

Identification	IEC motor size	Ø D mm	Ø D1 mm	Ø D2 mm	Ø G mm	Weight kg
HK DPT 160 NBR	71A / 71B	160,0	130,0	112,0	10	0,05
HK DPT 200 NBR	80A / 80B / 90S / 90L	200,0	165,0	147,0	12	0,05
HK DPT 250 NBR	100L / 112M	250,0	215,0	193,0	14	0,05
HK DPT 300 NBR	132S / 132M	300,0	265,0	245,0	14	0,08
HK DPT 350 NBR	160M / 160L / 180M / 180L	350,0	300,0	270,0	19	0,10
HK DPT 400 NBR	200L	400,0	350,0	303,0	19	0,16

Web: <http://cat.hansa-flex.com/en/HKDPT>

HK GP
Rubber-metallic buffer

With threaded bolt and inside thread
 Can also be used as an alternative to damping rails

Material: Galvanised steel

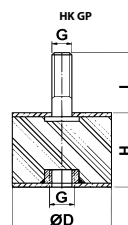

Ordering information: Other sizes and versions available on request

Identification	Ø D mm	G	H mm	L mm	permissible dyn. load N	Weight kg
HK GP 4030 M10 B	40,0	M 10	30,0	28,0	1150	0,3
HK GP 7540 M12 B	75,0	M 12	40,0	37,0	1600	0,5
HK GP 10040 M16 B	100,0	M 16	40,0	46,0	5600	0,8

Web: <http://cat.hansa-flex.com/en/HKGP>

HK B3/B5 230/400V

Electric motor B3/B5 230/400V

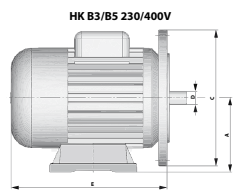

Self-cooling squirrel-cage motors
4-pin

Multi-range voltage 3-phase AC 220-240 V / 380-420 V at 50 Hz and 220-280 V / 380-480 V at 60 Hz

Design: type B3/B5, feet removable
Protection IP: IP 55
Ambient temperature: -20 °C to +40 °C
Material: Housing: Aluminium

Identification	n 50 Hz rpm	n 60 Hz rpm	P 50 Hz kW	P 60 Hz kW	I 50 Hz A	LF 50 Hz	A mm	E mm	Ø C mm	Ø D shaft mm	Weight kg
HK 71 A4 B35 2-4 A	1410	1710	0,25	0,30	0,91	0,67	71	206	160	14	6,1
HK 71 B4 B35 2-4 A	1380	1680	0,37	0,44	1,20	0,72	71	206	160	14	6,7
HK 80 A4 B35 2-4 A	1380	1680	0,55	0,66	1,58	0,74	80	228	200	19	8,9

P 50 Hz = nominal output at 400 V/50 Hz P 60 Hz = nominal output at 400 V/60 Hz n 50 Hz = nominal speed at 400 V/50 Hz n 60 Hz = nominal speed at 400 V/60 Hz I 50 Hz = nominal current at 400 V/50 Hz LF 50 Hz = cos phi power factor at 50 Hz

Web: <http://cat.hansa-flex.com/en/HKB3B5230400V>

HK B3/B5 230/400V IE2

Electric motor B3/B5 230/400V IE2



Self-cooling squirrel-cage energy-saving motors
High efficiency IE2 - IEC60034-30:2008
Rated voltage 230/400V 50Hz, 460V 60Hz; 4-pin
Voltage tolerance +- 5%

Design: type B3/B5, feet removable
Protection IP: IP 55
Ambient temperature: -20 °C to +40 °C
Material: Housing: Aluminium

Identification	n 50 Hz rpm	n 60 Hz rpm	P 50 Hz kW	P 60 Hz kW	I 50 Hz A	LF 50 Hz	A mm	H mm	B mm	C mm	Ø D shaft mm	Ø E mm	Ø F mm	η (IE2) %	Weight kg
HK 80M4 B35 2-4 IE2	1400	1700	0,75	0,86	1,81	0,75	125	80	260	220	19	130	200	79,6	12,3
HK 90S4 B35 2-4 IE2	1440	1740	1,10	1,30	2,50	0,77	140	90	280	250	24	130	200	81,4	15,0
HK 90L4 B35 2-4 IE2	1440	1740	1,50	1,75	3,40	0,77	140	90	310	250	24	130	200	82,8	18,0
HK 100LA4 B35 2-4 IE2	1455	1755	2,20	2,55	4,65	0,81	160	100	340	272	28	215	250	84,3	21,0
HK 100LB4 B35 2-4 IE2	1455	1755	3,00	3,45	6,20	0,82	160	100	340	272	28	215	250	85,5	25,0

P 50 Hz = nominal output at 400 V/50 Hz P 60 Hz = nominal output at 400 V/60 Hz n 50 Hz = nominal speed at 400 V/50 Hz n 60 Hz = nominal speed at 400 V/60 Hz I 50 Hz = nominal current at 400 V/50 Hz

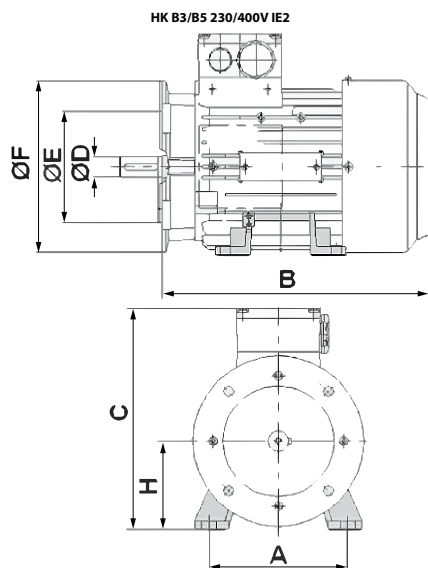

Web: <http://cat.hansa-flex.com/en/HKB3B5230400VIE2>

HK B5 230/400V IE2

Electric motor B5 230/400V IE2

Self-cooling squirrel-cage energy-saving motors
 High efficiency IE2 - IEC60034-30:2008
 Rated voltage 230/400V 50Hz, 460V 60Hz; 4-pin
 Voltage tolerance + - 5%

Design: type B5, without feet

Protection IP: IP 55

Ambient temperature: -20 °C to +40 °C

Material: Housing: Aluminium



Identification	n 50 Hz rpm	n 60 Hz rpm	P 50 Hz kW	P 60 Hz kW	I 50 Hz A	LF 50 Hz	H1 mm	B mm	C mm	Ø D shaft mm	Ø E mm	Ø F mm	η (IE2) %	Weight kg
HK 80M4 B5 2-4 IE2	1400	1700	0,75	0,86	1,81	0,75	120	268	200	19	130	200	79,6	12,3
HK 90S4 B5 2-4 IE2	1440	1740	1,10	1,30	2,50	0,77	128	281	218	24	130	200	81,4	15,0
HK 90L4 B5 2-4 IE2	1440	1740	1,50	1,75	3,40	0,77	128	326	218	24	130	200	82,8	18,0
HK 100LA4 B5 2-4 IE2	1455	1755	2,20	2,55	4,65	0,81	166	336	266	28	215	250	84,3	21,0
HK 100LB4 B5 2-4 IE2	1455	1755	3,00	3,45	6,20	0,82	166	336	266	28	215	250	85,5	25,0

P 50 Hz = nominal output at 400 V/50 Hz P 60 Hz = nominal output at 400 V/60 Hz n 50 Hz = nominal speed at 400 V/50 Hz n 60 Hz = nominal speed at 400 V/60 Hz I 50 Hz = nominal current at 400 V/50 Hz

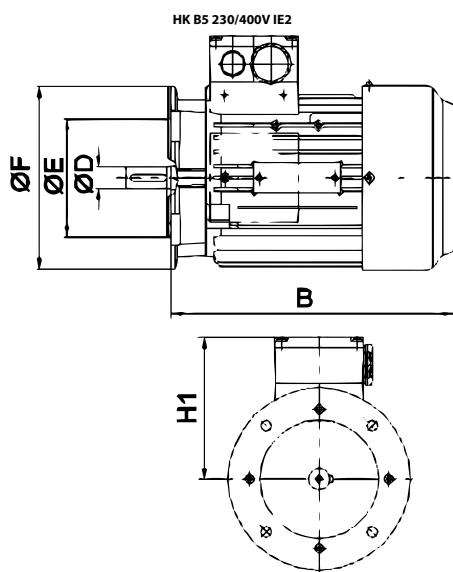

Web: <http://cat.hansa-flex.com/en/HKB5230400VIE2>

HK B3/B5 400/690V IE2

Electric motor B3/B5 400/690V IE2



Self-cooling squirrel-cage energy-saving motors
 High efficiency IE2 - IEC60034-30:2008
 Rated voltage 400/690V 50Hz, 460V 60Hz; 4-pin
 Voltage tolerance +- 5%
 Above 11 kW incl. temperature protection (PTC thermistor)
Design: type B3/B5, feet removable, feet fixed (from HK160M4 B35 4-6 IE2)
Protection IP: IP 55
Ambient temperature: -20 °C to +40 °C
Material: Housing: Aluminium, Housing: Grey cast iron (from HK160M4B354-6IE2)

Identification	n 50 Hz rpm	n 60 Hz rpm	P 50 Hz kW	P 60 Hz kW	I 50 Hz A	LF 50 Hz	A mm	H mm	B mm	C mm	Ø D shaft mm	Ø E mm	Ø F mm	η (IE2) %	Weight kg
HK 112M4 B35 4-6 IE2	1460	1760	4,00	4,60	8,20	0,81	190	112	375	302	28	180	250	85,5	29,0
HK 132SB4 B35 4-6 IE2	1460	1760	5,50	6,30	11,20	0,80	216	132	390	342	38	230	300	87,7	42,0

P 50 Hz = nominal output at 400 V/50 Hz P 60 Hz = nominal output at 400 V/60 Hz n 50 Hz = nominal speed at 400 V/50 Hz n 60 Hz = nominal speed at 400 V/60 Hz I 50 Hz = nominal current at 400 V/50 Hz

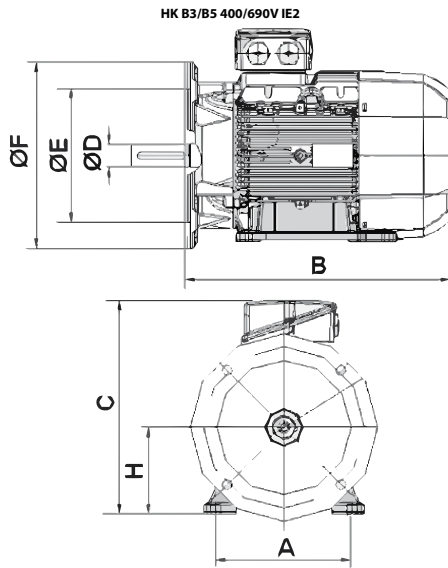

Web: <http://cat.hansa-flex.com/en/HKB3B5400690VIE2>

HK B5 400/690V IE2

Electric motor B5 400/690V IE2

Self-cooling squirrel-cage energy-saving motors
 High efficiency IE2 - IEC60034-30:2008
 Rated voltage 400/690V 50Hz, 460V 60Hz; 4-pin
 Voltage tolerance +- 5%
 Above 11 kW incl. temperature protection (PTC thermistor)

Design: type B5, without feet

Protection IP: IP 55

Ambient temperature: -20 °C to +40 °C

Material: Housing: Aluminium, Housing: Grey cast iron (from HK160M4B354-6IE2)



1

Identification	n 50 Hz rpm	n 60 Hz rpm	P 50 Hz kW	P 60 Hz kW	I 50 Hz A	LF 50 Hz	H1 mm	B mm	Ø D shaft mm	Ø E mm	Ø F mm	η (IE2) %	Weight kg
HK 112M4 B5 4-6 IE2	1460	1760	4,00	4,60	8,20	0,81	177	375	28	180	250	85,5	29,0
HK 132SB4 B5 4-6 IE2	1460	1760	5,50	6,30	11,20	0,80	202	390	38	230	300	87,7	42,0

P 50 Hz = nominal output at 400 V/50 Hz P 60 Hz = nominal output at 400 V/60 Hz n 50 Hz = nominal speed at 400 V/50 Hz n 60 Hz = nominal speed at 400 V/60 Hz I 50 Hz = nominal current at 400 V/50 Hz

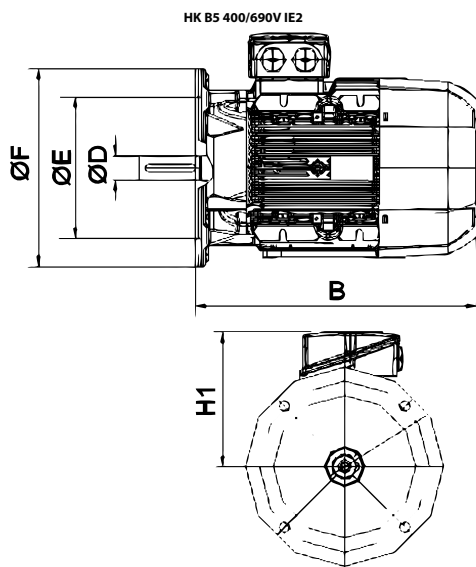

Web: <http://cat.hansa-flex.com/en/HKB5400690VIE2>

HK B3/B5 400/690V IE3

Electric motor B3/B5 400/690V IE3



Self-cooling squirrel-cage energy-saving motors
 High efficiency IE3 - IEC60034-30:2009
 Rated voltage 400/690V 50Hz, 460V 60Hz; 4-pin
 Voltage tolerance +- 5%
 Above 11 kW incl. temperature protection (PTC thermistor)

Design: type B3/B5, feet fixed
Protection IP: IP 55
Ambient temperature: -20 °C to +40 °C
Material: Housing: Aluminium, Housing: Grey cast iron (from HK180L4***)

1

Identification	n 50 Hz rpm	n 60 Hz rpm	P 50 Hz kW	P 60 Hz kW	I 50 Hz A	LF 50 Hz	A mm	H mm	B mm	C mm	Ø D shaft mm	Ø E mm	Ø F mm	η (IE3) %	Weight kg
HK 132M4 B35 4-6 IE3	1470	1770	7,50	8,60	14,30	0,84	216	132	453	357	38	230	300	90,4	49,0
HK 160M4 B35 4-6 IE3	1470	1770	11,00	12,60	20,60	0,84	254	160	545	420	42	250	350	91,4	71,0
HK 160L4 B35 4-6 IE3	1470	1770	15,00	17,30	27,60	0,86	254	160	604	420	42	250	350	92,1	83,0
HK 180M4 B35 4-6 IE3	1475	1775	18,50	21,30	33,80	0,86	279	180	628	460	48	250	350	92,6	160,0
HK 180L4 B35 4-6 IE3	1475	1775	22,00	25,30	40,00	0,86	279	180	668	460	48	250	350	93,0	185,0
HK 200L4 B35 4-6 IE3	1475	1775	30,00	34,50	54,30	0,86	318	200	660	505	55	300	400	93,6	225,0
HK 225S4 B35 4-6 IE3	1480	1780	37,00	42,50	66,70	0,86	356	225	680	560	60	350	450	93,9	285,0
HK 225M4 B35 4-6 IE3	1480	1780	45,00	52,00	80,90	0,86	356	225	705	560	60	350	450	94,2	315,0
HK 250M4 B35 4-6 IE3	1480	1780	55,00	63,00	98,40	0,86	406	250	770	620	60	450	550	94,6	395,0

P 50 Hz = nominal output at 400 V/50 Hz P 60 Hz = nominal output at 400 V/60 Hz n 50 Hz = nominal speed at 400 V/50 Hz n 60 Hz = nominal speed at 400 V/60 Hz I 50 Hz = nominal current at 400 V/50 Hz

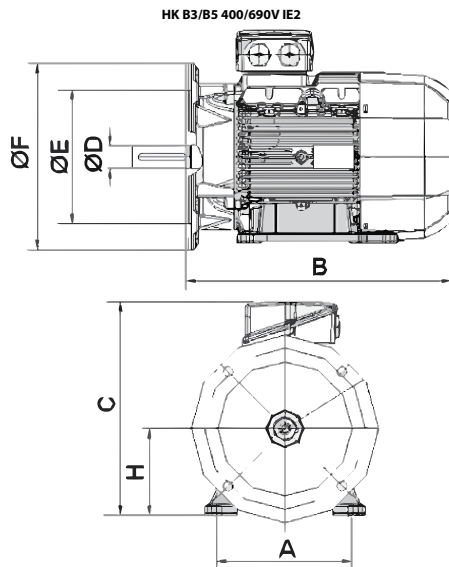

Web: <http://cat.hansa-flex.com/en/HKB3B5400690VIE3>

HK B5 400/690V IE3
Electric motor B5 400/690V IE3

Self-cooling squirrel-cage energy-saving motors
 High efficiency IE3 - IEC60034-30:2009
 Rated voltage 400/690V 50Hz, 460V 60Hz; 4-pin
 Voltage tolerance +- 5%
 Above 11 kW incl. temperature protection (PTC thermistor)

Design: type B5, without feet

Protection IP: IP 55

Ambient temperature: -20 °C to +40 °C

Material: Housing: Aluminium, Housing: Grey cast iron (from HK180L4***)



Identification	n 50 Hz		n 60 Hz		P 50 Hz		P 60 Hz		I 50 Hz	LF 50 Hz	H1	A	H	B	Ø D shaft	Ø E	Ø F	C	η (IE3) %	Weight
	rpm	rpm	kW	kW	A	mm	mm	mm												
HK 132M4 B5 4-6 IE3	1470	1770	7,50	8,60	14,30	0,84	225							453	38	230	300		90,4	48,0
HK 160M4 B5 4-6 IE3	1470	1770	11,00	12,60	20,60	0,84	260							545	42	250	350		91,4	70,0
HK 160L4 B5 4-6 IE3	1470	1770	15,00	17,30	27,60	0,86	260							604	42	250	350		92,1	82,0
HK 180M4 B5 4-6 IE3	1475	1775	18,50	21,30	33,80	0,86	280							628	48	250	350		92,6	159,0
HK 180L4 B5 4-6 IE3	1475	1775	22,00	25,30	40,00	0,86	280							668	48	250	350		93,0	184,0
HK 200L4 B5 4-6 IE3	1475	1775	30,00	34,50	54,30	0,86	305							660	55	300	400		93,6	224,0
HK 225S4 B5 4-6 IE3	1480	1780	37,00	42,50	66,70	0,86	335							680	60	350	450		93,9	284,0
HK 225M4 B5 4-6 IE3	1480	1780	45,00	52,00	80,90	0,86	335							705	60	350	450		94,2	314,0
HK 250M4 B5 4-6 IE3	1480	1780	55,00	63,00	98,40	0,86	370	406	250	770	60	450	550	620					94,6	390,0

P 50 Hz = nominal output at 400 V/50 Hz P 60 Hz = nominal output at 400 V/60 Hz n 50 Hz = nominal speed at 400 V/50 Hz n 60 Hz = nominal speed at 400 V/60 Hz I 50 Hz = nominal current at 400 V/50 Hz

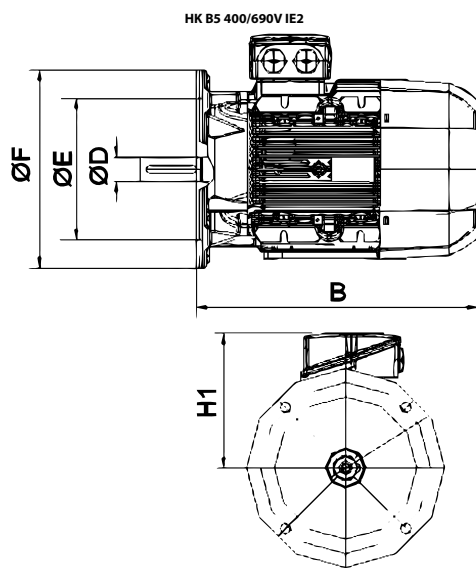

Web: <http://cat.hansa-flex.com/en/HKB5400690VIE3>

HK B3/B14 230V

Electric motor B3/B14 230V



Self-cooled single-phase AC motors
 230V AC, 4-pin
 FCSP version - with operating capacitor
 FBSP HT version - with starting/operating capacitor
Design: type B3/B14, feet removable
Protection IP: IP 55
Ambient temperature: -20 °C to +40 °C
Material: Housing: Aluminium, painted

1

Identification	n 50 Hz rpm	P 50 Hz kW	I 50 Hz A	LF 50 Hz	H mm	A mm	B mm	C mm	Ø D shaft mm	Ø E mm	Ø F mm	Weight kg
HK K 201 FCSP	1400	0,18	1,62	0,90	63	100	207	185	11	60	90	5,0
HK K 202 FCSP	1390	0,25	1,99	0,92	71	112	225	205	14	70	105	7,0
HK K 202 FBSP HT	1390	0,25	2,02	0,92	71	112	225	210	14	70	105	6,1
HK K 203 FCSP	1410	0,37	2,81	0,92	71	112	225	205	14	70	105	8,0
HK K 203 FBSP HT	1410	0,37	2,95	0,92	71	112	225	210	14	70	105	7,6
HK K 204 FCSP	1370	0,55	4,00	0,92	80	125	255	235	19	80	120	11,0
HK K 204 FBSP HT	1370	0,55	4,25	0,92	80	125	255	240	19	80	120	8,9
HK K 205 FCSP	1410	0,75	5,22	0,92	80	125	255	235	19	80	120	13,0
HK K 205 FBSP HT	1410	0,75	5,45	0,92	80	125	255	240	19	80	120	10,0
HK K 206 FCSP	1410	1,10	7,20	0,95	90	140	285	265	24	95	140	15,0
HK K 206 FBSP HT	1410	1,10	7,45	0,95	90	140	285	270	24	95	140	14,5
HK K 207 FCSP	1410	1,50	9,57	0,95	90	140	310	265	24	95	140	17,5
HK K 207 FBSP HT	1410	1,50	9,83	0,95	90	140	310	270	24	95	140	16,0
HK K 208 FCSP	1430	2,20	13,09	0,95	100	160	320	275	28	110	160	24,5
HK K 208 FBSP HT	1430	2,20	13,48	0,95	100	160	320	280	28	110	160	21,0

P 50 Hz = nominal output at 230 V/50 Hz n 50 Hz = nominal speed at 230 V/50 Hz I 50 Hz = nominal current at 230 V/50 Hz LF 50 Hz = cos phi power factor at 50 Hz

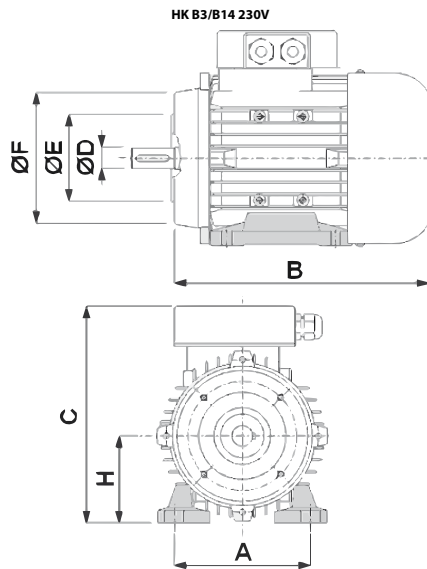

Web: <http://cat.hansa-flex.com/en/HKB3B14230V>

HK B3/B14 230/400V

Electric motor B3/B14 230/400V

Self-cooling squirrel-cage motors

Rated voltage 230/400V 50Hz, 460V 60Hz; 4-pin

Design: type B3/B14, feet removable**Protection IP:** IP 55**Ambient temperature:** -20 °C to +40 °C**Material:** Housing: Aluminium, painted

Identification	n 50 Hz rpm	P 50 Hz kW	I 50 Hz A	LF 50 Hz	H mm	A mm	B mm	C mm	Ø D shaft mm	Ø E mm	Ø F mm	Weight kg
HK K 401 FCPA	1360	0,18	0,60	0,73	63	100	194	174	11	60	90	4,5
HK K 402 FCPA	1380	0,25	0,80	0,74	71	112	215	189	14	70	105	6,0
HK K 403 FCPA	1380	0,37	1,10	0,75	71	112	215	189	14	70	105	6,5
HK K 404 FCPA	1380	0,55	1,50	0,75	80	125	250	209	19	80	120	9,0

P 50 Hz = nominal output at 400 V/50 Hz n 50 Hz = nominal speed at 400 V/50 Hz I 50 Hz = nominal current at 400 V/50 Hz LF 50 Hz = cos phi power factor at 50 Hz

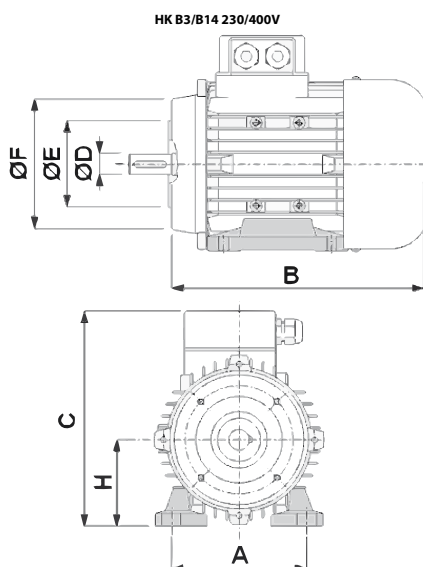

Web: <http://cat.hansa-flex.com/en/HKB3B14230400V>

HK B3/B14 230/400V IE2

Electric motor B3/B14 230/400V IE2



Self-cooling squirrel-cage energy-saving motors
 High efficiency IE2 - IEC60034-30:2008
 Rated voltage 230/400V 50Hz, 460V 60Hz; 4-pin
 Voltage tolerance +- 5%

Design: type B3/B14, feet removable
Protection IP: IP 55
Ambient temperature: -20 °C to +40 °C
Material: Housing: Aluminium, painted

1

Identification	n 50 Hz rpm	P 50 Hz kW	I 50 Hz A	LF 50 Hz	H mm	A mm	B mm	C mm	Ø D shaft mm	Ø E mm	Ø F mm	η (IE2) %	Weight kg
HK K 405A 80B4 IE2	1430	0,75	1,90	0,71	80	125	250	209	19	80	120	79,6	11,9
HK K 406A 90SA4 IE2	1420	1,10	2,50	0,77	90	140	275	230	24	95	140	81,4	14,9
HK K 407A 90LB4 IE2	1430	1,50	3,40	0,76	90	140	300	230	24	95	140	82,8	17,0
HK K 408A 100LA4 IE2	1440	2,20	4,70	0,79	100	160	338	256	28	110	160	84,3	27,2
HK K 409A 100LB4 IE2	1440	3,00	6,50	0,77	100	160	338	256	28	110	160	85,5	26,5

P 50 Hz = nominal output at 400 V/50 Hz n 50 Hz = nominal speed at 400 V/50 Hz I 50 Hz = nominal current at 400 V/50 Hz LF 50 Hz = cos phi power factor at 50 Hz η (IE2) = efficiency to IE2 in % (at full load)

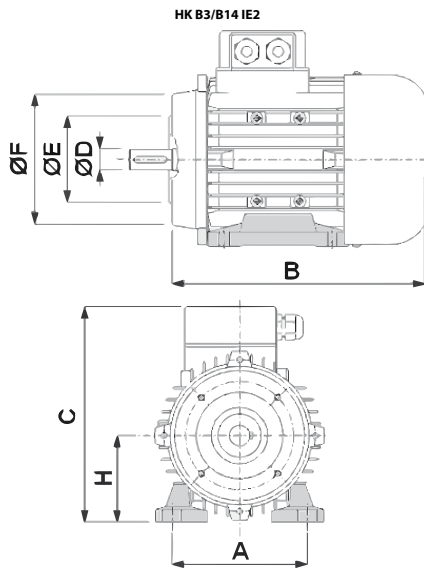

Web: <http://cat.hansa-flex.com/en/HKB3B14230400VIE2>

HK B3/B14 400/690V IE2
Electric motor B3/B14 400/690V IE2

Self-cooling squirrel-cage energy-saving motors
 High efficiency IE2 - IEC60034-30:2008
 Rated voltage 400/690V 50Hz, 460V 60Hz; 4-pin
 Voltage tolerance +- 5%

Design: type B3/B14, feet removable

Protection IP: IP 55

Ambient temperature: -20 °C to +40 °C

Material: Housing: Aluminium, painted



Note: Progressive motor versions have a higher power rating than DIN compliant motors, but are the same build size.

Identification	n 50 Hz rpm	P 50 Hz kW	I 50 Hz A	LF 50 Hz	H mm	A mm	Design	B mm	C mm	Ø D shaft mm	Ø E mm	Ø F mm	η (IE2) %	Weight kg
HK K 410A 112MA4 IE2	1450	4,00	8,40	0,79	112	190	-	387	278	28	110	160	85,5	32,3
HK K 411A 112MC4 IE2	1440	5,50	10,90	0,83	112	190	progressive	387	278	28	110	160	87,7	36,0

P 50 Hz = nominal output at 400 V/50 Hz n 50 Hz = nominal speed at 400 V/50 Hz I 50 Hz = nominal current at 400 V/50 Hz LF 50 Hz = cos phi power factor at 50 Hz η (IE2) = efficiency to IE2 in % (at full load)

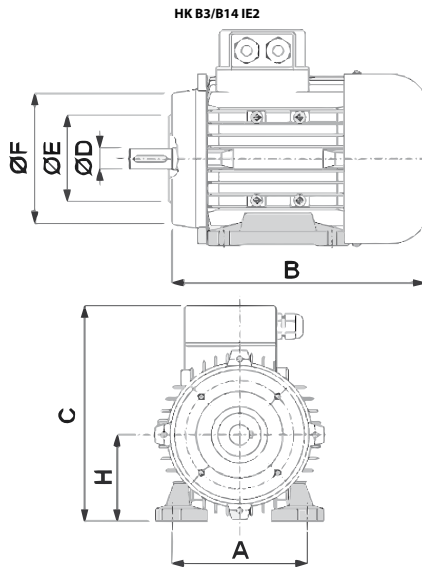

Web: <http://cat.hansa-flex.com/en/HKB3B14400690VIE2>

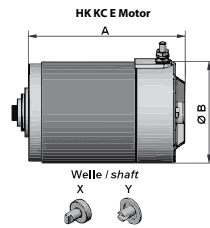
HK K C E-Motor 12V
DC 12V electric motor

Design:
Voltage:

 Direct current motor for industrial applications
 12 V

Identification	A	Design	Ø B	Power	Direction of rotation	Speed max.	Cyclic duration factor S2 operation	Cyclic duration factor S3 operation	Protection class	Shaft	Weight
	mm		mm	kW		rpm	min	%			kg
HK KC 40	158,5		80,0	0,5	reversible	2500	5,0	17,0	IP 54	type Y Ø15.6 x 6.5 x 10.5	2,60
HK KC 78	215,5	with fan	112,5	1,5	clockwise rotating	2300	4,0	14,0	IP 23	type X Ø17.9 x 8.3 x 9.0	7,72
HK KC 85	158,5	with thermal contact	80,0	0,8	reversible	3500	4,0	9,0	IP 44	type Y Ø15.6 x 6.5 x 10.5	2,60
HK KC 91	173,5		114,0	1,6	clockwise rotating	2600	3,0	7,5	IP 54	type X Ø17.9 x 8.3 x 9.0	6,80
HK KC 96	207,5	with thermal contact	131,0	2,4	clockwise rotating	2600	1,0	8,0	IP 54	type X Ø16.8 x 8.0 x 7.0	11,28
HK KC 98	183,0		114,0	1,5	clockwise rotating	2300	2,0	8,0	IP 54	type X Ø17.9 x 8.3 x 9.0	7,14
HK KC 102	173,5	with thermal contact	114,0	1,6	clockwise rotating	2600	3,0	7,5	IP 54	type X Ø17.9 x 8.3 x 9.0	6,70

Web: <http://cat.hansa-flex.com/en/HKKCEMOTOR12V>
Accessories:

HK K REL - Start relay for DC electric motor

HK K CAP - Cap for DC electric motors

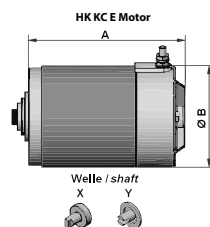
HK K C E-Motor 24V
DC 24V electric motor

Design:
Voltage:

 Direct current motor for industrial applications
 24 V

Identification	A	Design	Ø B	Power	Direction of rotation	Speed max.	Cyclic duration factor S2 operation	Cyclic duration factor S3 operation	Protection class	Shaft	Weight
	mm		mm	kW		rpm	min	%			kg
HK KC 41	158,5		80,0	0,5	reversible	2800	5,0	17,0	IP 54	type Y Ø15.6 x 6.5 x 10.5	2,60
HK KC 79	215,5	with fan	112,5	2,0	clockwise rotating	2200	4,5	10,0	IP 23	type X Ø17.9 x 8.3 x 9.0	7,75
HK KC 92	173,5		114,0	2,2	clockwise rotating	2600	1,2	4,5	IP 54	type X Ø17.9 x 8.3 x 9.0	6,90
HK KC 94	158,5		80,0	0,8	reversible	4000	2,5	8,0	IP 54	type Y Ø15.6 x 6.5 x 10.5	2,60
HK KC 95	237,0		131,0	3,0	clockwise rotating	2600	4,0	15,0	IP 54	type X Ø16.8 x 8.0 x 7.0	12,60
HK KC 97	183,0		114,0	2,0	clockwise rotating	2200	2,0	5,0	IP 54	type X Ø17.9 x 8.3 x 9.0	7,16
HK KC 103	173,5	with thermal contact	114,0	2,2	clockwise rotating	2600	1,2	4,5	IP 54	type X Ø17.9 x 8.3 x 9.0	6,70
HK KC 104	237,0	with thermal contact	131,0	3,0	clockwise rotating	2600	4,0	15,0	IP 54	type X Ø16.8 x 8.0 x 7.0	12,50
HK KC 111	237,0	with fan	131,0	3,0	clockwise rotating	3300	6,0	20,0	IP 12	type X Ø16.8 x 8.0 x 7.0	12,50

Web: <http://cat.hansa-flex.com/en/HKKCEMOTOR24V>
Accessories:

HK K REL - Start relay for DC electric motor

HK K CAP - Cap for DC electric motors

HK K C E-Motor 48V

DC 48V electric motor

Design: Direct current motor for industrial applications
Voltage: 48 V

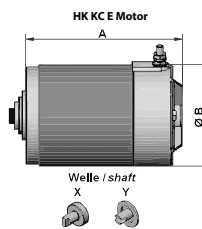

Identification	A	Ø B	Power	Direction of rotation	Speed max. rpm	Cyclic duration factor S2 operation min	Cyclic duration factor S3 operation %	Protection class	Shaft	Weight kg
HK KC 86	183,0 mm	114,0 mm	2,0 kW	clockwise rotating	2500	1,0	5,0	IP 54	type X Ø17.9 x 8.3 x 9.0	7,3

Web: <http://cat.hansa-flex.com/en/HKKCEMOTOR48V>

Accessories:

- HK K REL - Start relay for DC electric motor
- HK K CAP - Cap for DC electric motors

HK K CAP

Cap for DC electric motors

Material: PVC
Use: Suitable direct current motors HK KC 91, HK KC 92, HK KC 97, HK KC 98, HK KC103



Identification	Weight kg
HK K 1	0,05

Web: <http://cat.hansa-flex.com/en/HKKCAP>

Accessory for following products:

- HK K C E-Motor 12V - DC 12V electric motor
- HK K C E-Motor 24V - DC 24V electric motor
- HK K C E-Motor 48V - DC 48V electric motor

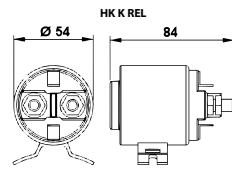
HK K REL**Start relay for DC electric motor**

Design: solenoid-switch start relay
Scope of supply: with counter nut

Identification	Voltage	Current consumption (nominal)		Current consumption max.		Weight kg
		A		A		
HK K C	12 V	150	350	350	0,75	
HK K C300	12 V	300	350	350	1,30	
HK K E	24 V	150	350	350	0,73	
HK K F	48 V	60	200	200	0,71	

Web: <http://cat.hansa-flex.com/en/HKKREL>

Accessory for following products:

HK K C E-Motor 12V - DC 12V electric motor

HK K C E-Motor 24V - DC 24V electric motor

HK K C E-Motor 48V - DC 48V electric motor

Standard double-acting cylinders with fastening

Our hydraulic cylinders and their components are designed for standard applications in industry and agriculture. They can be used only in some circumstances for applications in construction machinery. If this is your intention, please contact our technical personnel. The cylinders conform to the technical specifications in the catalogue or are designed to customers' specifications (approval drawing).

Please observe the stipulations of EN ISO 4413 "Safety requirements for fluid power systems and their components" as well as specifications and safety requirements based on statutory regulations when selecting, installing and operating the cylinders.

Design: with attachment elements

Operating pressure: max. 200 bar (acc. DIN EN 982)

Test pressure: max. 240 bar (acc. DIN EN 982)

Temp. range: Standard version -15 °C to +80 °C

Media: HLP fluids

Material: Piston rod: Steel 20MnV6, Chrome 25 µm ±/ - 5, Piston rod: Resistance for 120 h in the NSS test according to ISO 3768, Piston rod guide: Steel 9SMn28, Oil filler neck: Steel 9SMn28, Polished cylinder barrel: ST 52.3 DIN 2393-ISO H9, Cylinder base: FE 510-A105, Nut: Steel 8UNI EN20898/2, Gasket TPM: NBR, Piston: Steel 9SMn28, Gasket OR: NBR Fluorosil Viton, Gasket TSE-TTS-TTI/L: NBR + fabric / polyurethane, Gasket GHM-GHK: NBR / polyurethane

Note: HK HFR0 16 guide housing of aluminium

Piston speed based on standard seals: Max. 25m/min - 0.42m/sec.

Piston speed to the end positions: max. 6m/min - 0.10m/sec.

For these standard cylinders, it is recommended not to weld any fastenings to the cylinder liner (e.g. cardan mountings) as this could distort it.



Identification	Ø D	Ø A	Ø S	Stroke	Z	Ø E	M	N	L	L1	Ø F	G	Weight
	mm	mm	mm	mm	mm	mm	mm	mm	mm	mm	mm	mm	kg
HK HFR 0 16 0050	35	25	16	50	160	1/4"	22	64	25	25	12,1	35	0,95
HK HFR 0 16 0100	35	25	16	100	210	1/4"	22	64	25	25	12,1	35	1,25
HK HFR 0 16 0150	35	25	16	150	260	1/4"	22	64	25	25	12,1	35	1,49
HK HFR 0 16 0200	35	25	16	200	310	1/4"	22	64	25	25	12,1	35	1,77
HK HFR 0 20 0050	42	32	20	50	205	1/4"	35	84	35	35	16,2	40	1,70
HK HFR 0 20 0100	42	32	20	100	255	1/4"	35	84	35	35	16,2	40	2,03
HK HFR 0 20 0150	42	32	20	150	305	1/4"	35	84	35	35	16,2	40	2,40
HK HFR 0 20 0200	42	32	20	200	355	1/4"	35	84	35	35	16,2	40	2,77
HK HFR 0 20 0250	42	32	20	250	405	1/4"	35	84	35	35	16,2	40	3,11
HK HFR 0 20 0300	42	32	20	300	455	1/4"	35	84	35	35	16,2	40	3,48
HK HFR 0 20 0400	42	32	20	400	555	1/4"	35	84	35	35	16,2	40	4,19
HK HFR 0 20 0500	42	32	20	500	655	1/4"	35	84	35	35	16,2	40	4,90

Ø A = piston diameter Ø S = piston rod diameter

HK HFR Zylinder

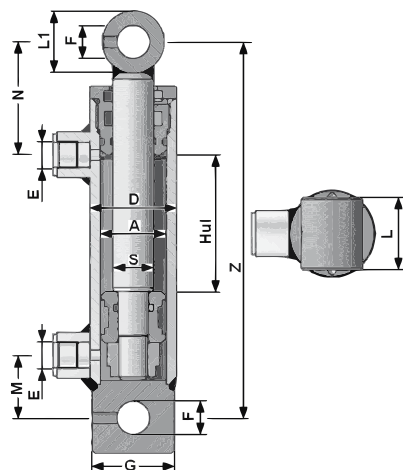

Web: <http://cat.hansa-flex.com/en/HKHFR>

HK HFR2S

Standard double-acting cylinders with fastening



Our hydraulic cylinders and their components are designed for standard applications in industry and agriculture. They can be used only in some circumstances for applications in construction machinery. If this is your intention, please contact our technical personnel. The cylinders conform to the technical specifications in the catalogue or are designed to customers' specifications (approval drawing).

Please observe the stipulations of EN ISO 4413 "Safety requirements for fluid power systems and their components" as well as specifications and safety requirements based on statutory regulations when selecting, installing and operating the cylinders.

Design: with attachment elements
Operating pressure: max. 200 bar (acc. DIN EN 982)
Test pressure: max. 240 bar (acc. DIN EN 982)
Temp. range: Standard version -15 °C to +80 °C
Media: HLP fluids
Material: Piston rod: Steel 20MnV6, Chrome 25 µm ±/ - 5, Piston rod: Resistance for 120 h in the NSS test according to ISO 3768, Piston rod guide: Steel 9SMn28, Oil filler neck: Steel 9SMn28, Polished cylinder barrel: ST 52.3 DIN 2393-ISO H9, Cylinder base: FE 510-A105, Nut: Steel 8UNI EN20898/2, Gasket TPM: NBR, Piston: Steel 9SMn28, Gasket OR: NBR Fluorosil Viton, Gasket TSE-TTS-TTI/L: NBR + fabric / polyurethane, Gasket GHM-GHK: NBR / polyurethane

Note: From type HK HFR2S 060 piston safeguard by means of safety bolt

Piston speed based on standard seals: Max. 25m/min - 0.42m/sec.

Piston speed to the end positions: max. 6m/min - 0.10m/sec.

For these standard cylinders, it is recommended not to weld any fastenings to the cylinder liner (e.g. cardan mountings) as this could distort it.

Identification	Ø D mm	Ø A mm	Ø S mm	Stroke mm	Z mm	Ø E mm	M mm	N mm	L mm	L1 mm	Ø F mm	G mm	Weight kg
HK HFR2S 040 025 0100	50	40	25	100	270	3/8"	38	105	40	35	20,25	50	3,0
HK HFR2S 040 025 0150	50	40	25	150	320	3/8"	38	105	40	35	20,25	50	3,4
HK HFR2S 040 025 0200	50	40	25	200	370	3/8"	38	105	40	35	20,25	50	3,9
HK HFR2S 040 025 0250	50	40	25	250	420	3/8"	38	105	40	35	20,25	50	4,4
HK HFR2S 040 025 0300	50	40	25	300	470	3/8"	38	105	40	35	20,25	50	4,8
HK HFR2S 040 025 0400	50	40	25	400	570	3/8"	38	105	40	35	20,25	50	5,8
HK HFR2S 040 025 0500	50	40	25	500	670	3/8"	38	105	40	35	20,25	50	6,7
HK HFR2S 040 025 0600	50	40	25	600	770	3/8"	38	105	40	35	20,25	50	7,6
HK HFR2S 040 025 0700	50	40	25	700	870	3/8"	38	105	40	35	20,25	50	8,6
HK HFR2S 040 025 0800	50	40	25	800	970	3/8"	38	105	40	35	20,25	50	9,5
HK HFR2S 050 030 0100	60	50	30	100	300	3/8"	42	128	45	40	25,25	60	4,4
HK HFR2S 050 030 0150	60	50	30	150	350	3/8"	42	128	45	40	25,25	60	5,0
HK HFR2S 050 030 0200	60	50	30	200	400	3/8"	42	128	45	40	25,25	60	5,6
HK HFR2S 050 030 0250	60	50	30	250	450	3/8"	42	128	45	40	25,25	60	6,2
HK HFR2S 050 030 0300	60	50	30	300	500	3/8"	42	128	45	40	25,25	60	6,9
HK HFR2S 050 030 0400	60	50	30	400	600	3/8"	42	128	45	40	25,25	60	8,1
HK HFR2S 050 030 0500	60	50	30	500	700	3/8"	42	128	45	40	25,25	60	9,3
HK HFR2S 050 030 0600	60	50	30	600	800	3/8"	42	128	45	40	25,25	60	10,5
HK HFR2S 050 030 0700	60	50	30	700	900	3/8"	42	128	45	40	25,25	60	11,8
HK HFR2S 050 030 0800	60	50	30	800	1000	3/8"	42	128	45	40	25,25	60	13,0
HK HFR2S 060 030 0100	70	60	30	100	300	3/8"	36	133	45	40	25,25	70	5,6
HK HFR2S 060 030 0150	70	60	30	150	350	3/8"	36	133	45	40	25,25	70	6,3
HK HFR2S 060 030 0200	70	60	30	200	400	3/8"	36	133	45	40	25,25	70	7,0
HK HFR2S 060 030 0250	70	60	30	250	450	3/8"	36	133	45	40	25,25	70	7,7
HK HFR2S 060 030 0300	70	60	30	300	500	3/8"	36	133	45	40	25,25	70	8,3
HK HFR2S 060 030 0350	70	60	30	350	550	3/8"	36	133	45	40	25,25	70	9,0
HK HFR2S 060 030 0400	70	60	30	400	600	3/8"	36	133	45	40	25,25	70	9,7
HK HFR2S 060 030 0450	70	60	30	450	650	3/8"	36	133	45	40	25,25	70	10,4
HK HFR2S 060 030 0500	70	60	30	500	700	3/8"	36	133	45	40	25,25	70	11,0
HK HFR2S 060 030 0600	70	60	30	600	800	3/8"	36	133	45	40	25,25	70	12,4
HK HFR2S 060 030 0700	70	60	30	700	900	3/8"	36	133	45	40	25,25	70	13,7
HK HFR2S 060 035 0200	70	60	35	200	400	3/8"	36	133	45	40	25,25	70	7,5
HK HFR2S 060 035 0300	70	60	35	300	500	3/8"	36	133	45	40	25,25	70	9,0
HK HFR2S 060 035 0400	70	60	35	400	600	3/8"	36	133	45	40	25,25	70	10,6
HK HFR2S 060 035 0500	70	60	35	500	700	3/8"	36	133	45	40	25,25	70	12,1
HK HFR2S 060 035 0600	70	60	35	600	800	3/8"	36	133	45	40	25,25	70	13,7
HK HFR2S 060 035 0700	70	60	35	700	900	3/8"	36	133	45	40	25,25	70	15,2
HK HFR2S 070 040 0200	80	70	40	200	410	3/8"	46	132	55	50	30,25	80	10,1
HK HFR2S 070 040 0250	80	70	40	250	460	3/8"	46	132	55	50	30,25	80	11,0
HK HFR2S 070 040 0300	80	70	40	300	510	3/8"	46	132	55	50	30,25	80	12,0
HK HFR2S 070 040 0350	80	70	40	350	560	3/8"	46	132	55	50	30,25	80	13,0
HK HFR2S 070 040 0400	80	70	40	400	610	3/8"	46	132	55	50	30,25	80	13,9
HK HFR2S 070 040 0450	80	70	40	450	660	3/8"	46	132	55	50	30,25	80	14,9
HK HFR2S 070 040 0500	80	70	40	500	710	3/8"	46	132	55	50	30,25	80	15,8
HK HFR2S 070 040 0600	80	70	40	600	810	3/8"	46	132	55	50	30,25	80	17,7
HK HFR2S 070 040 0700	80	70	40	700	910	3/8"	46	132	55	50	30,25	80	19,6
HK HFR2S 080 040 0200	92	80	40	200	410	3/8"	42	130	55	50	30,25	90	13,0
HK HFR2S 080 040 0250	92	80	40	250	460	3/8"	42	130	55	50	30,25	90	14,2
HK HFR2S 080 040 0300	92	80	40	300	510	3/8"	42	130	55	50	30,25	90	15,3

Ø A = piston diameter Ø S = piston rod diameter



(Continued)

HK HFR2S

Standard double-acting cylinders with fastening

Identification	Ø D mm	Ø A mm	Ø S mm	Stroke mm	Z mm	Ø E mm	M mm	N mm	L mm	L1 mm	Ø F mm	G mm	Weight kg
HK HFR2S 080 040 0350	92	80	40	350	560	3/8"	42	130	55	50	30,25	90	16,4
HK HFR2S 080 040 0400	92	80	40	400	610	3/8"	42	130	55	50	30,25	90	17,5
HK HFR2S 080 040 0500	92	80	40	500	710	3/8"	42	130	55	50	30,25	90	19,8
HK HFR2S 080 040 0600	92	80	40	600	810	3/8"	42	130	55	50	30,25	90	22,0
HK HFR2S 080 040 0700	92	80	40	700	910	3/8"	42	130	55	50	30,25	90	24,3
HK HFR2S 100 050 0200	115	100	50	200	425	1/2"	45	141	70	60	30,25	115	21,5
HK HFR2S 100 050 0300	115	100	50	300	525	1/2"	45	141	70	60	30,25	115	25,0
HK HFR2S 100 050 0400	115	100	50	400	625	1/2"	45	141	70	60	30,25	115	28,5
HK HFR2S 100 050 0500	115	100	50	500	725	1/2"	45	141	70	60	30,25	115	32,0
HK HFR2S 100 050 0700	115	100	50	700	925	1/2"	45	141	70	60	30,25	115	39,1

Ø A = piston diameter Ø S = piston rod diameter

HK HFR Zylinder

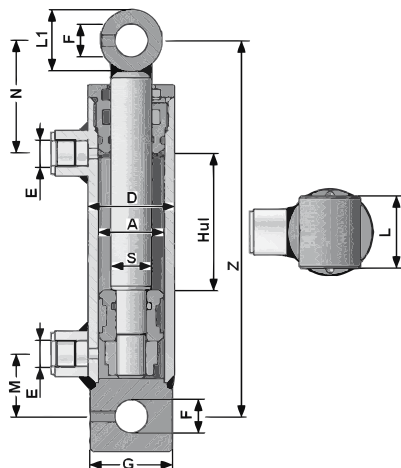
 Web: <http://cat.hansa-flex.com/en/HKHFR2S>

HK HFRT

Standard single-acting cylinders with fastening



Our hydraulic cylinders and their components are designed for standard applications in industry and agriculture. They can be used only in some circumstances for applications in construction machinery. If this is your intention, please contact our technical personnel. The cylinders conform to the technical specifications in the catalogue or are designed to customers' specifications (approval drawing).

Please observe the stipulations of EN ISO 4413 "Safety requirements for fluid power systems and their components" as well as specifications and safety requirements based on statutory regulations when selecting, installing and operating the cylinders.

Design: Plunger cylinders, with attachment elements

Operating pressure: max. 200 bar (acc. DIN EN 982)

Test pressure: max. 240 bar (acc. DIN EN 982)

Temp. range: Standard version -15 °C to +80 °C

Media: HLP fluids

Material: Piston rod: Steel 20MnV6, Chrome 25 µm ±/ - 5, Piston rod: Resistance for 120 h in the NSS test according to ISO 3768, Piston rod guide: Steel 9SMn28, Oil filler neck: Steel 9SMn28, Polished cylinder barrel: ST 52.3 DIN 2393-ISO H9, Cylinder base: FE 510-A105, Nut: Steel 8UNI EN20898/2, Gasket TPM: NBR, Piston: Steel 9SMn28, Gasket OR: NBR Fluorosil Viton, Gasket TSE-TTS-TTI/L: NBR + fabric / polyurethane, Gasket GHM-GHK: NBR / polyurethane

Note: Piston speed based on standard seals: Max. 25m/min - 0.42m/sec.

Piston speed to the end positions: max. 6m/min - 0.10m/sec.

For these standard cylinders, it is recommended not to weld any fastenings to the cylinder liner (e.g. cardan mountings) as this could distort it.

Identification	Ø S mm	Stroke mm	Z mm	Ø E mm	M mm	Ø H mm	L mm	Ø F mm	Ø G mm	Weight kg
HK HFRT 1 25 100	25	100	190	3/8"	40,00	22	35	14,00	40	1,63
HK HFRT 1 25 150	25	150	240	3/8"	40,00	22	35	14,00	40	2,04
HK HFRT 1 25 200	25	200	290	3/8"	40,00	22	35	14,00	40	2,44
HK HFRT 1 25 250	25	250	340	3/8"	40,00	22	35	14,00	40	2,85
HK HFRT 1 25 300	25	300	390	3/8"	40,00	22	35	14,00	40	3,26
HK HFRT 2 30 200	30	200	300	3/8"	42,00	27	37	16,00	50	3,61
HK HFRT 2 30 250	30	250	350	3/8"	42,00	27	37	16,00	50	4,16
HK HFRT 2 30 300	30	300	400	3/8"	42,00	27	37	16,00	50	4,72
HK HFRT 2 30 350	30	350	450	3/8"	42,00	27	37	16,00	50	5,27
HK HFRT 2 30 400	30	400	500	3/8"	42,00	27	37	16,00	50	5,82
HK HFRT 2 30 550	30	550	650	3/8"	42,00	27	37	16,00	50	7,30
HK HFRT 3 40 200	40	200	330	3/8"	47,00	37	49	23,00	60	6,00
HK HFRT 3 40 250	40	250	380	3/8"	47,00	37	49	23,00	60	6,84
HK HFRT 3 40 300	40	300	430	3/8"	47,00	37	49	23,00	60	7,67
HK HFRT 3 40 350	40	350	480	3/8"	47,00	37	49	23,00	60	8,49
HK HFRT 3 40 400	40	400	530	3/8"	47,00	37	49	23,00	60	9,32
HK HFRT 3 40 550	40	550	680	3/8"	47,00	37	49	23,00	60	11,70
HK HFRT 3 40 700	40	700	830	3/8"	47,00	37	49	23,00	60	14,10
HK HFRT 4 50 300	50	300	460	3/8"	50,00	47	65	25,50	65	11,80
HK HFRT 4 50 400	50	400	560	3/8"	50,00	47	65	25,50	65	14,00
HK HFRT 4 50 550	50	550	710	3/8"	50,00	47	65	25,50	65	17,50
HK HFRT 4 50 700	50	700	860	3/8"	50,00	47	65	25,50	65	21,00

Ø S = piston rod diameter

HK HFRT Zylinder

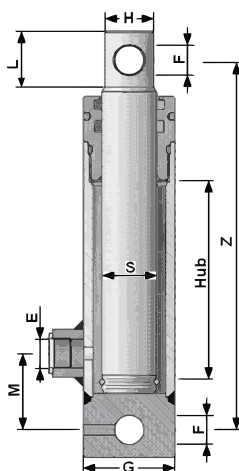

Web: <http://cat.hansa-flex.com/en/HKHFRT>

Standard double-acting cylinders without fastening

Our hydraulic cylinders and their components are designed for standard applications in industry and agriculture. They can be used only in some circumstances for applications in construction machinery. If this is your intention, please contact our technical personnel. The cylinders conform to the technical specifications in the catalogue or are designed to customers' specifications (approval drawing).

Please observe the stipulations of EN ISO 4413 "Safety requirements for fluid power systems and their components" as well as specifications and safety requirements based on statutory regulations when selecting, installing and operating the cylinders.

Design: without mounting elements

Operating pressure: max. 200 bar (acc. DIN EN 982)

Test pressure: max. 240 bar (acc. DIN EN 982)

Temp. range: Standard version -15 °C to +80 °C

Media: HLP fluids

Material: Piston rod: Steel 20MnV6, Chrome 25 µm ±/ - 5, Piston rod: Resistance for 120 h in the NSS test according to ISO 3768, Piston rod guide: Steel 95Mn28, Oil filler neck: Steel 95Mn28, Polished cylinder barrel: ST 52.3 DIN 2393-ISO H9, Cylinder base: FE 510-A105, Nut: Steel 8UNI EN20898/2, Gasket TPM: NBR, Piston: Steel 95Mn28, Gasket OR: NBR Fluorosil Viton, Gasket TSE-TTS-TTI/L: NBR + fabric / polyurethane, Gasket GHM-GHK: NBR / polyurethane

Note: Piston speed based on standard seals: Max. 25m/min - 0.42m/sec.

Piston speed to the end positions: max. 6m/min - 0.10m/sec.

For these standard cylinders, it is recommended not to weld any fastenings to the cylinder liner (e.g. cardan mountings) as this could distort it.



Identification	Ø D mm	Ø A mm	Ø S mm	Stroke mm	Z mm	C mm	E	L mm	L1 mm	Weight kg
HK HM 01 20 0100	50	40	20	100	230	22,0	G 1/4"	40	23	2,27
HK HM 01 20 0150	50	40	20	150	280	22,0	G 1/4"	40	23	2,67
HK HM 01 20 0200	50	40	20	200	330	22,0	G 1/4"	40	23	3,05
HK HM 01 20 0250	50	40	20	250	380	22,0	G 1/4"	40	23	3,45
HK HM 01 20 0300	50	40	20	300	430	22,0	G 1/4"	40	23	3,85
HK HM 01 20 0350	50	40	20	350	480	22,0	G 1/4"	40	23	4,27
HK HM 01 20 0400	50	40	20	400	530	22,0	G 1/4"	40	23	4,65
HK HM 01 20 0450	50	40	20	450	580	22,0	G 1/4"	40	23	5,08
HK HM 01 20 0500	50	40	20	500	630	22,0	G 1/4"	40	23	5,49
HK HM 01 25 0100	50	40	25	100	230	22,0	G 1/4"	40	23	2,75
HK HM 01 25 0150	50	40	25	150	280	22,0	G 1/4"	40	23	2,95
HK HM 01 25 0200	50	40	25	200	330	22,0	G 1/4"	40	23	3,39
HK HM 01 25 0250	50	40	25	250	380	22,0	G 1/4"	40	23	3,85
HK HM 01 25 0300	50	40	25	300	430	22,0	G 1/4"	40	23	4,32
HK HM 01 25 0350	50	40	25	350	480	22,0	G 1/4"	40	23	4,79
HK HM 01 25 0400	50	40	25	400	530	22,0	G 1/4"	40	23	5,26
HK HM 01 25 0450	50	40	25	450	580	22,0	G 1/4"	40	23	5,72
HK HM 01 25 0500	50	40	25	500	630	22,0	G 1/4"	40	23	6,20
HK HM 01 25 0550	50	40	25	550	680	22,0	G 1/4"	40	23	6,60
HK HM 01 25 0600	50	40	25	600	730	22,0	G 1/4"	40	23	7,13
HK HM 02 25 0100	60	50	25	100	240	22,0	G 3/8"	43	26	3,29
HK HM 02 25 0150	60	50	25	150	290	22,0	G 3/8"	43	26	3,83
HK HM 02 25 0200	60	50	25	200	340	22,0	G 3/8"	43	26	4,34
HK HM 02 25 0250	60	50	25	250	390	22,0	G 3/8"	43	26	4,85
HK HM 02 25 0300	60	50	25	300	440	22,0	G 3/8"	43	26	5,35
HK HM 02 25 0350	60	50	25	350	490	22,0	G 3/8"	43	26	5,94
HK HM 02 25 0400	60	50	25	400	540	22,0	G 3/8"	43	26	6,40
HK HM 02 25 0450	60	50	25	450	590	22,0	G 3/8"	43	26	7,30
HK HM 02 25 0500	60	50	25	500	640	22,0	G 3/8"	43	26	7,43
HK HM 02 25 0550	60	50	25	550	690	22,0	G 3/8"	43	26	8,06
HK HM 02 25 0600	60	50	25	600	740	22,0	G 3/8"	43	26	8,46
HK HM 02 25 0800	60	50	25	800	940	22,0	G 3/8"	43	26	10,71
HK HM 02 25 1000	60	50	25	1000	1140	22,0	G 3/8"	43	26	12,87
HK HM 02 30 0150	60	50	30	150	290	22,0	G 3/8"	43	26	4,11
HK HM 02 30 0200	60	50	30	200	340	22,0	G 3/8"	43	26	4,74
HK HM 02 30 0250	60	50	30	250	390	22,0	G 3/8"	43	26	5,35
HK HM 02 30 0300	60	50	30	300	440	22,0	G 3/8"	43	26	5,97
HK HM 02 30 0350	60	50	30	350	490	22,0	G 3/8"	43	26	6,55
HK HM 02 30 0400	60	50	30	400	540	22,0	G 3/8"	43	26	7,20
HK HM 02 30 0450	60	50	30	450	590	22,0	G 3/8"	43	26	7,80
HK HM 02 30 0500	60	50	30	500	640	22,0	G 3/8"	43	26	8,42
HK HM 02 30 0550	60	50	30	550	690	22,0	G 3/8"	43	26	9,04
HK HM 02 30 0600	60	50	30	600	740	22,0	G 3/8"	43	26	9,64
HK HM 02 30 0800	60	50	30	800	940	22,0	G 3/8"	43	26	12,10
HK HM 02 30 1000	60	50	30	1000	1140	22,0	G 3/8"	43	26	14,57
HK HM 03 30 0100	70	60	30	100	260	23,0	G 3/8"	50	30	4,82
HK HM 03 30 0150	70	60	30	150	310	23,0	G 3/8"	50	30	5,55
HK HM 03 30 0200	70	60	30	200	360	23,0	G 3/8"	50	30	6,20
HK HM 03 30 0250	70	60	30	250	410	23,0	G 3/8"	50	30	6,87
HK HM 03 30 0300	70	60	30	300	460	23,0	G 3/8"	50	30	7,55
HK HM 03 30 0350	70	60	30	350	510	23,0	G 3/8"	50	30	8,20
HK HM 03 30 0400	70	60	30	400	560	23,0	G 3/8"	50	30	8,90
HK HM 03 30 0450	70	60	30	450	610	23,0	G 3/8"	50	30	9,53
HK HM 03 30 0500	70	60	30	500	660	23,0	G 3/8"	50	30	10,25
HK HM 03 30 0550	70	60	30	550	710	23,0	G 3/8"	50	30	10,83
HK HM 03 30 0600	70	60	30	600	760	23,0	G 3/8"	50	30	11,60
HK HM 03 30 0800	70	60	30	800	960	23,0	G 3/8"	50	30	14,26
HK HM 03 30 1000	70	60	30	1000	1160	23,0	G 3/8"	50	30	17,00
HK HM 03 35 0100	70	60	35	100	260	23,0	G 3/8"	50	30	5,07
HK HM 03 35 0150	70	60	35	150	310	23,0	G 3/8"	50	30	5,85

Ø A = piston diameter Ø S = piston rod diameter

HK HM

(Continued)

Standard double-acting cylinders without fastening

Identification	Ø D mm	Ø A mm	Ø S mm	Stroke mm	Z mm	C mm	E	L mm	L1 mm	Weight kg
HK HM 03 35 0200	70	60	35	200	360	23,0	G 3/8"	50	30	6,60
HK HM 03 35 0250	70	60	35	250	410	23,0	G 3/8"	50	30	7,40
HK HM 03 35 0300	70	60	35	300	460	23,0	G 3/8"	50	30	8,15
HK HM 03 35 0350	70	60	35	350	510	23,0	G 3/8"	50	30	8,94
HK HM 03 35 0400	70	60	35	400	560	23,0	G 3/8"	50	30	9,72
HK HM 03 35 0450	70	60	35	450	610	23,0	G 3/8"	50	30	10,47
HK HM 03 35 0500	70	60	35	500	660	23,0	G 3/8"	50	30	11,25
HK HM 03 35 0550	70	60	35	550	710	23,0	G 3/8"	50	30	12,00
HK HM 03 35 0600	70	60	35	600	760	23,0	G 3/8"	50	30	12,81
HK HM 03 35 0800	70	60	35	800	960	23,0	G 3/8"	50	30	15,87
HK HM 03 35 1000	70	60	35	1000	1160	23,0	G 3/8"	50	30	18,93
HK HM 03 40 0200	70	60	40	200	360	23,0	G 3/8"	50	30	7,25
HK HM 03 40 0250	70	60	40	250	410	23,0	G 3/8"	50	30	8,14
HK HM 03 40 0300	70	60	40	300	460	23,0	G 3/8"	50	30	9,03
HK HM 03 40 0350	70	60	40	350	510	23,0	G 3/8"	50	30	9,90
HK HM 03 40 0400	70	60	40	400	560	23,0	G 3/8"	50	30	10,79
HK HM 03 40 0450	70	60	40	450	610	23,0	G 3/8"	50	30	11,64
HK HM 03 40 0500	70	60	40	500	660	23,0	G 3/8"	50	30	12,52
HK HM 03 40 0550	70	60	40	550	710	23,0	G 3/8"	50	30	13,45
HK HM 03 40 0600	70	60	40	600	760	23,0	G 3/8"	50	30	14,30
HK HM 03 40 0800	70	60	40	800	960	23,0	G 3/8"	50	30	17,82
HK HM 03 40 1000	70	60	40	1000	1160	23,0	G 3/8"	50	30	21,40
HK HM 04 30 0200	80	70	30	200	360	23,0	G 3/8"	50	33	7,50
HK HM 04 35 0100	80	70	35	100	260	23,0	G 3/8"	50	33	6,09
HK HM 04 35 0150	80	70	35	150	310	23,0	G 3/8"	50	33	6,95
HK HM 04 35 0200	80	70	35	200	360	23,0	G 3/8"	50	33	7,74
HK HM 04 35 0250	80	70	35	250	410	23,0	G 3/8"	50	33	8,60
HK HM 04 35 0300	80	70	35	300	460	23,0	G 3/8"	50	33	9,40
HK HM 04 35 0350	80	70	35	350	510	23,0	G 3/8"	50	33	10,26
HK HM 04 35 0400	80	70	35	400	560	23,0	G 3/8"	50	33	11,00
HK HM 04 35 0450	80	70	35	450	610	23,0	G 3/8"	50	33	11,88
HK HM 04 35 0500	80	70	35	500	660	23,0	G 3/8"	50	33	12,60
HK HM 04 35 0550	80	70	35	550	710	23,0	G 3/8"	50	33	13,66
HK HM 04 35 0600	80	70	35	600	760	23,0	G 3/8"	50	33	14,20
HK HM 04 35 0800	80	70	35	800	960	23,0	G 3/8"	50	33	17,56
HK HM 04 35 1000	80	70	35	1000	1160	23,0	G 3/8"	50	33	21,26
HK HM 04 40 0100	80	70	40	100	260	23,0	G 3/8"	50	33	8,20
HK HM 04 40 0200	80	70	40	200	360	23,0	G 3/8"	50	33	8,20
HK HM 04 40 0250	80	70	40	250	410	23,0	G 3/8"	50	33	9,26
HK HM 04 40 0300	80	70	40	300	460	23,0	G 3/8"	50	33	10,24
HK HM 04 40 0350	80	70	40	350	510	23,0	G 3/8"	50	33	11,20
HK HM 04 40 0400	80	70	40	400	560	23,0	G 3/8"	50	33	12,80
HK HM 04 40 0450	80	70	40	450	610	23,0	G 3/8"	50	33	13,11
HK HM 04 40 0500	80	70	40	500	660	23,0	G 3/8"	50	33	14,01
HK HM 04 40 0550	80	70	40	550	710	23,0	G 3/8"	50	33	15,10
HK HM 04 40 0600	80	70	40	600	760	23,0	G 3/8"	50	33	15,99
HK HM 04 40 0800	80	70	40	800	960	23,0	G 3/8"	50	33	19,73
HK HM 04 40 1000	80	70	40	1000	1160	23,0	G 3/8"	50	33	23,51
HK HM 05 40 0200	92	80	40	200	380	25,0	G 1/2"	60	35	11,08
HK HM 05 40 0250	92	80	40	250	430	25,0	G 1/2"	60	35	12,22
HK HM 05 40 0300	92	80	40	300	480	25,0	G 1/2"	60	35	13,36
HK HM 05 40 0400	92	80	40	400	580	25,0	G 1/2"	60	35	15,56
HK HM 05 40 0500	92	80	40	500	680	25,0	G 1/2"	60	35	17,77
HK HM 05 40 0600	92	80	40	600	780	25,0	G 1/2"	60	35	19,98
HK HM 05 40 0800	92	80	40	800	980	25,0	G 1/2"	60	35	24,50
HK HM 05 40 1000	92	80	40	1000	1180	25,0	G 1/2"	60	35	29,03
HK HM 05 50 0200	92	80	50	200	380	25,0	G 1/2"	60	35	12,35
HK HM 05 50 0250	92	80	50	250	430	25,0	G 1/2"	60	35	13,73
HK HM 05 50 0300	92	80	50	300	480	25,0	G 1/2"	60	35	15,15
HK HM 05 50 0400	92	80	50	400	580	25,0	G 1/2"	60	35	17,93
HK HM 05 50 0500	92	80	50	500	680	25,0	G 1/2"	60	35	20,71
HK HM 05 50 0600	92	80	50	600	780	25,0	G 1/2"	60	35	23,49
HK HM 05 50 0800	92	80	50	800	980	25,0	G 1/2"	60	35	29,50
HK HM 05 50 1000	92	80	50	1000	1180	25,0	G 1/2"	60	35	35,00
HK HM 06 50 0200	115	100	50	200	410	25,0	G 1/2"	82	38	19,50
HK HM 06 50 0250	115	100	50	250	460	25,0	G 1/2"	82	38	21,50
HK HM 06 50 0300	115	100	50	300	510	25,0	G 1/2"	82	38	23,00
HK HM 06 50 0400	115	100	50	400	610	25,0	G 1/2"	82	38	26,50
HK HM 06 50 0500	115	100	50	500	710	25,0	G 1/2"	82	38	30,00
HK HM 06 50 0600	115	100	50	600	810	25,0	G 1/2"	82	38	33,50
HK HM 06 50 0800	115	100	50	800	1010	25,0	G 1/2"	82	38	40,50
HK HM 06 50 1000	115	100	50	1000	1210	25,0	G 1/2"	82	38	47,50
HK HM 06 60 0300	115	100	60	300	510	25,0	G 1/2"	82	38	25,50
HK HM 06 60 0400	115	100	60	400	610	25,0	G 1/2"	82	38	29,50
HK HM 06 60 0500	115	100	60	500	710	25,0	G 1/2"	82	38	33,50
HK HM 06 60 0600	115	100	60	600	810	25,0	G 1/2"	82	38	37,50
HK HM 06 60 0800	115	100	60	800	1010	25,0	G 1/2"	82	38	46,00
HK HM 06 60 1000	115	100	60	1000	1210	25,0	G 1/2"	82	38	54,50

Ø A = piston diameter Ø S = piston rod diameter

(Continued)

HK HM

Standard double-acting cylinders without fastening

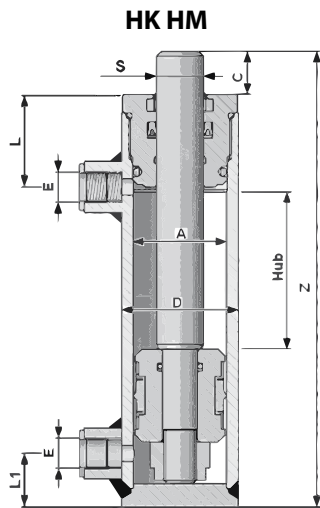

Web: <http://cat.hansa-flex.com/en/HKHM>

1

HK HT
Standard single-acting cylinders without fastening

Our hydraulic cylinders and their components are designed for standard applications in industry and agriculture. They can be used only in some circumstances for applications in construction machinery. If this is your intention, please contact our technical personnel. The cylinders conform to the technical specifications in the catalogue or are designed to customers' specifications (approval drawing).

Please observe the stipulations of EN ISO 4413 "Safety requirements for fluid power systems and their components" as well as specifications and safety requirements based on statutory regulations when selecting, installing and operating the cylinders.

Design: Plunger cylinders, without mounting elements

Operating pressure: max. 200 bar (acc. DIN EN 982)

Test pressure: max. 240 bar (acc. DIN EN 982)

Temp. range: Standard version -15 °C to +80 °C

Media: HLP fluids

Material: Piston rod: Steel 20MnV6, Chrome 25 µm ±/- 5, Piston rod: Resistance for 120 h in the NSS test according to ISO 3768, Piston rod guide: Steel 9SMn28, Oil filler neck: Steel 9SMn28, Polished cylinder barrel: ST 52.3 DIN 2393-ISO H9, Cylinder base: FE 510-A105, Nut: Steel 8UNI EN20898/2, Gasket TPM: NBR, Piston: Steel 9SMn28, Gasket OR: NBR Fluorosil Viton, Gasket TSE-TTS-TTI/L: NBR + fabric / polyurethane, Gasket GHM-GHK: NBR / polyurethane

Note: Piston speed based on standard seals: Max. 25m/min - 0.42m/sec.

Piston speed to the end positions: max. 6m/min - 0.10m/sec.

For these standard cylinders, it is recommended not to weld any fastenings to the cylinder liner (e.g. cardan mountings) as this could distort it.

Identification	Ø D mm	Ø S mm	Stroke mm	Z mm	C mm	T mm	E	L1 mm	Weight kg
HK HT 02 30 0200	50	30	200	326	40,0	256,0	G 3/8"	23	3,64
HK HT 02 30 0250	50	30	250	376	40,0	303,0	G 3/8"	23	4,19
HK HT 02 30 0300	50	30	300	426	40,0	353,0	G 3/8"	23	4,75
HK HT 02 30 0350	50	30	350	476	40,0	403,0	G 3/8"	23	5,31
HK HT 02 30 0400	50	30	400	526	40,0	453,0	G 3/8"	23	5,86
HK HT 02 30 0500	50	30	500	626	40,0	553,0	G 3/8"	23	6,96
HK HT 03 40 0200	60	40	200	338	45,0	258,0	G 3/8"	26	5,64
HK HT 03 40 0300	60	40	300	438	45,0	358,0	G 3/8"	26	7,29
HK HT 03 40 0400	60	40	400	538	45,0	458,0	G 3/8"	26	8,98
HK HT 03 40 0500	60	40	500	638	45,0	558,0	G 3/8"	26	13,00
HK HT 03 40 0600	60	40	600	738	45,0	658,0	G 3/8"	26	12,28
HK HT 04 50 0300	70	50	300	450	50,0	365,0	G 3/8"	30	10,47
HK HT 04 50 0400	70	50	400	550	50,0	465,0	G 3/8"	30	12,86
HK HT 04 50 0500	70	50	500	650	50,0	565,0	G 3/8"	30	15,14
HK HT 04 50 0600	70	50	600	750	50,0	665,0	G 3/8"	30	17,50

Ø S = piston rod diameter

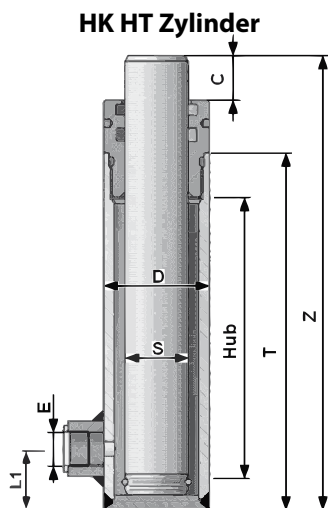

HK HT Zylinder

Web: <http://cat.hansa-flex.com/en/HKHT>

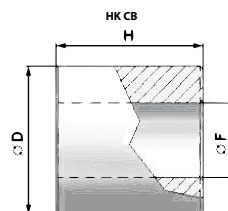
HK CB
Swivel bearing bushing
Material: Steel 9SMn28

Identification	Ø D mm	Ø F mm	H mm	Weight kg
HK CB 16 035 030	35,0	16,20	30,0	0,18
HK CB 16 035 060	35,0	16,20	60,0	0,36
HK CB 20 040 040	40,0	20,30	40,0	0,29
HK CB 20 040 070	40,0	20,30	70,0	0,50
HK CB 25 050 050	50,0	25,30	50,0	0,56
HK CB 25 050 080	50,0	25,30	80,0	0,89
HK CB 25 050 090	50,0	25,30	90,0	1,02
HK CB 30 060 060	60,0	30,30	60,0	0,97
HK CB 30 060 110	60,0	30,30	110,0	1,79
HK CB 40 070 070	70,0	40,30	70,0	1,60
HK CB 40 070 130	70,0	40,30	130,0	2,65

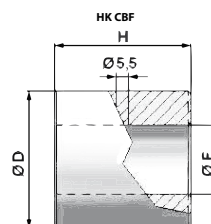
Web: <http://cat.hansa-flex.com/en/HKCB>
HK CBF
Swivel bearing bushing with bore
Material: Steel 9SMn28

Identification	Ø D mm	Ø F mm	H mm	Weight kg
HK CBF 0035 065 060	65,0	35,50	60,0	1,10
HK CBF 0035 065 120	65,0	35,50	120,0	2,20
HK CBF 0050 085 080	85,0	50,50	80,0	2,30
HK CBF 0050 085 140	85,0	50,50	140,0	4,00
HK CBF 0060 100 090	100,0	60,50	90,0	3,50
HK CBF 0060 100 150	100,0	60,50	150,0	5,85

Web: <http://cat.hansa-flex.com/en/HKCBF>

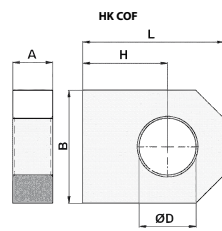
HK COF
COF swivel bearing

Material: Steel FE 37

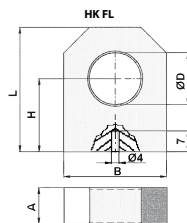
Identification	A mm	B mm	H mm	L mm	Ø D mm	Weight kg
HK COF 16 00000	20	35	25	42	16,20	0,18
HK COF 20 00000	25	45	30	50	20,25	0,35
HK COF 25 00000	30	50	35	60	25,25	0,56
HK COF 30 00000	35	60	45	75	30,25	0,56
HK COF 35 00000	40	70	55	90	35,25	0,97
HK COF 40 00000	40	70	60	95	40,25	1,50
HK COF 50 00000	40	90	75	120	50,50	2,63
HK COF 60 00000	50	100	90	140	60,50	4,21

Web: <http://cat.hansa-flex.com/en/HKCOF>
HK FL
FL swivel bearing

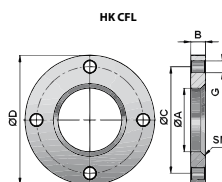
Material: Steel FE 37

Identification	A mm	B mm	H mm	L mm	Ø D mm	Weight kg
HK FL 16	15,0	35,0	34,0	50,0	16,20	0,19
HK FL 20	20,0	40,0	40,0	60,0	20,25	0,38
HK FL 25	25,0	50,0	45,0	65,0	25,25	0,58
HK FL 30	30,0	60,0	50,0	75,0	30,25	0,79
HK FL 35	35,0	70,0	55,0	85,0	35,25	0,98
HK FL 40	40,0	80,0	60,0	100,0	40,25	1,22

Web: <http://cat.hansa-flex.com/en/HKFL>
HK CFL
CFL flange

Material: Steel FE 510C

Note: Tolerance for ØA: +0.2

Identification	Ø A mm	Ø C mm	Ø D mm	B mm	G	SM	Weight kg
HK CFL 0035 072	35,0	60	72,0	10,00	4 x Ø 7	3 x 45°	0,23
HK CFL 0040 080	40,0	65	80,0	12,00	4 x Ø 9	3 x 45°	0,33
HK CFL 0042 089	42,0	70	89,0	12,00	4 x Ø 9	3 x 45°	0,43
HK CFL 0045 095	45,0	75	95,0	12,00	4 x Ø 9	3 x 45°	0,50
HK CFL 0050 109	50,0	87	109,0	12,50	4 x Ø 11	4 x 45°	0,66
HK CFL 0055 123	55,0	100	123,0	14,50	4 x Ø 11	4 x 45°	1,00
HK CFL 0060 128	60,0	105	128,0	14,50	4 x Ø 13	4 x 45°	1,09
HK CFL 0065 135	65,0	110	135,0	15,50	4 x Ø 13	4 x 45°	1,30

(Continued)

HK CFL

CFL flange

Identification	Ø A mm	Ø C mm	Ø D mm	B mm	G	SM	Weight kg
HK CFL 0070 142	70,0	117	142,0	16,50	4 x Ø 13	5 x 45°	1,50
HK CFL 0073 145	73,0	120	145,0	16,50	4 x Ø 13	5 x 45°	1,50
HK CFL 0075 152	75,0	125	152,0	16,50	4 x Ø 13	5 x 45°	1,68
HK CFL 0080 162	80,0	127	162,0	16,50	4 x Ø 15	5 x 45°	1,94
HK CFL 0090 175	90,0	145	175,0	18,50	4 x Ø 15	5 x 45°	2,44
HK CFL 0095 181	95,0	149	181,0	18,50	6 x Ø 17	7 x 45°	2,53
HK CFL 0100 188	100,0	155	188,0	18,50	6 x Ø 17	7 x 45°	2,81
HK CFL 0105 188	105,0	156	188,0	24,50	6 x Ø 17	8 x 45°	3,44
HK CFL 0115 194	115,0	162	194,0	24,50	6 x Ø 17	8 x 45°	3,47
HK CFL 0125 228	123,0	190	228,0	28,00	6 x Ø 21	8 x 45°	5,95
HK CFL 0140 240	138,0	200	240,0	28,00	6 x Ø 21	8 x 45°	6,10
HK CFL 0145 250	143,0	210	250,0	28,00	6 x Ø 21	8 x 45°	6,65
HK CFL 0160 280	158,0	230	280,0	33,00	6 x Ø 23	10 x 45°	9,98
HK CFL 0170 300	168,0	250	300,0	38,00	6 x Ø 25	12 x 45°	13,30
HK CFL 0180 325	178,0	270	325,0	38,00	6 x Ø 28	12 x 45°	15,90

Web: <http://cat.hansa-flex.com/en/HKCFL>

HK CFS

Yoke end, short

Material: Stöell FE 52

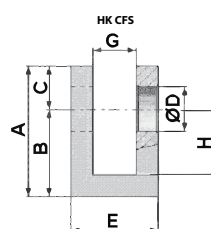

Identification	A mm	B mm	C mm	E mm	G mm	H mm	Ø D mm	Width mm	Weight kg
HK CFS 00000 16	50,00	34,00	16,0	35,00	16,00	24,0	16,20	35,0	0,27
HK CFS 00000 20	60,00	40,00	20,0	40,00	20,00	30,0	20,25	40,0	0,38
HK CFS 00000 25	70,00	45,00	25,0	50,00	25,00	30,0	25,25	50,0	0,71
HK CFS 00000 30	80,00	50,00	30,0	60,00	30,00	35,0	30,25	60,0	1,10
HK CFS 00000 35	90,00	55,00	35,0	70,00	35,00	40,0	35,25	70,0	1,60
HK CFS 00000 40	110,00	70,00	40,0	80,00	40,00	50,0	40,25	80,0	2,70
HK CFS 00000 50	145,00	95,00	50,0	100,00	50,00	60,0	50,50	100,0	5,86
HK CFS 00000 60	160,00	105,00	60,0	110,00	60,00	55,0	60,50	110,0	7,10

Web: <http://cat.hansa-flex.com/en/HKCFS>

HK CFP

Yoke end, long

Material: Steel FE 37

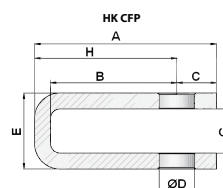

Identification	A mm	B mm	C mm	E mm	G mm	H mm	Ø D mm	Profile	Weight kg
HK CFP 40 10 125	125,00	95,00	20,0	40,50	20,50	105,0	20,25	40 x 10	0,5
HK CFP 45 10 067	67,00	30,00	27,0	43,00	23,00	40,0	20,25	45 x 10	1,0
HK CFP 45 10 132	132,00	97,00	25,0	48,00	28,00	107,0	22,25	45 x 10	1,0
HK CFP 50 15 135	135,00	95,00	25,0	52,00	22,00	110,0	26,25	50 x 15	1,3
HK CFP 50 15 140	140,00	95,00	30,0	63,00	33,00	110,0	26,25	50 x 15	1,5
HK CFP 60 20 175	175,00	125,00	30,0	75,00	35,00	145,0	26,25	60 x 20	3,0
HK CFP 60 20 180	180,00	130,00	30,0	80,00	40,00	150,0	26,25	60 x 20	3,5

Web: <http://cat.hansa-flex.com/en/HKCFP>

HK CFF

Yoke end with thread

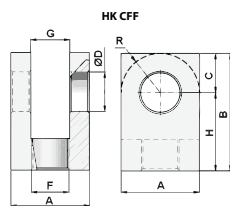

Material: St52 FE 52

Identification	A mm	B mm	C mm	F	G mm	H mm	Ø D mm	R mm	Weight kg
HK CFF 016 1615	35,00	55,00	16,0	M 16x1.5	16,00	39,0	16,20		0,30
HK CFF 020 2015	40,00	65,00	20,0	M 20x1.5	20,00	45,0	20,25		0,40
HK CFF 025 2420	50,00	75,00	25,0	M 24x2	25,00	50,0	25,25		0,75
HK CFF 030 3020	60,00	95,00	30,0	M 30x2	30,00	65,0	30,25	30,00	1,46
HK CFF 035 3320	70,00	110,00	35,0	M 33x2	35,00	75,0	35,25	35,00	1,67
HK CFF 040 3320	80,00	125,00	40,0	M 33x2	40,00	85,0	40,25	40,00	3,20
HK CFF 050 4530	100,00	150,00	50,0	M 45x3	50,00	100,0	50,50	50,00	5,82
HK CFF 060 5640	110,00	165,00	55,0	M 56x4	60,00	110,0	60,50	55,00	7,10

Web: <http://cat.hansa-flex.com/en/HKCFF>

HK CSR

Pivot yoke

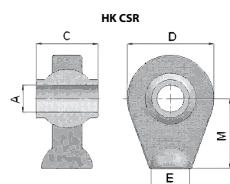

Application: Agricultural machines
Material: Steel C40

Identification	C mm	E	M mm	A mm	Design	D mm	Weight kg
HK CSR 00 107 08	44,0	Ø 34	58,00	19,3	flat-machined	62	0,60
HK CSR 00 107 20	44,0	Ø 34	58,00	20,2	flat-machined	62	0,60
HK CSR 00 107 25	35,0	Ø 26	50,00	22,2	rough	62	0,55
HK CSR 00 107 40	51,0	Ø 38	65,00	25,4	flat-machined	75	1,10
HK CSR 00 108 10	55,0	Ø 50	65,00	30,2	flat-machined	83	1,40
HK CSR 00 108 12	35,0	Ø 50	65,00	35,2	flat-machined	83	1,20
HK CSR 00 108 20	75,0	Ø 60	85,00	40,2	flat-machined	108	3,35
HK CSR 00 108 40	75,0	Ø 60	85,00	45,2	flat-machined	108	3,15
HK CSR 00 108 60	75,0	Ø 60	85,00	50,2	flat-machined	108	2,90

Web: <http://cat.hansa-flex.com/en/HKCSR>

HK CSR 104

Pivot yoke

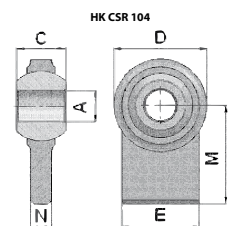

Application: Agricultural machines
Material: Steel C40

Identification	C mm	E mm	M mm	N mm	A mm	Design	D mm	Weight kg
HK CSR 00 104 95	20,0	30	60,00	11,0	16,2	flat-machined	46	0,26

Web: <http://cat.hansa-flex.com/en/HKCSR104>

HK CSTS C

Pivot yoke with regreasable bearings

Standard: DIN 648, E SERIES, TYPE C
Application: Industry
Material: Steel ST 52.3

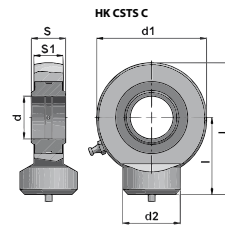

Note: HKCSTS012C00 cannot be re-lubricated
 HKCSTS015C00, HKCSTS016C00, HKCSTS017C00 and HKCSTS020C00 can only be lubricated by a lubrication hole (no grease nipple)

Identification	d	d1	d2	l	L	S1	S	allowable dyn. load	Weight
	mm	mm	mm	mm	mm	mm	mm	kN	kg
HK CSTS 012 C 00	12	34	16,0	27	44,0	8	10	10	0,06
HK CSTS 015 C 00	15	40	20,0	31	51,0	10	12	17	0,12
HK CSTS 016 C 00	16	46	21,5	35	58,0	11	14	19	0,17
HK CSTS 017 C 00	17	46	22,5	35	58,0	11	14	21	0,18
HK CSTS 020 C 00	20	53	27,5	38	64,5	13	15	30	0,25
HK CSTS 025 C 00	25	64	33,5	45	77,0	17	20	48	0,45
HK CSTS 030 C 00	30	73	40,0	51	87,5	19	22	62	0,67
HK CSTS 035 C 00	35	82	47,0	61	102,0	21	25	80	0,98
HK CSTS 040 C 00	40	92	52,0	69	115,0	23	28	100	1,35
HK CSTS 045 C 00	45	102	58,0	77	128,0	27	32	127	1,93
HK CSTS 050 C 00	50	112	62,0	88	144,0	30	35	156	2,65
HK CSTS 060 C 00	60	135	70,0	100	167,5	38	44	245	4,60
HK CSTS 070 C 00	70	160	80,0	115	195,0	42	49	315	7,00
HK CSTS 080 C 00	80	180	95,0	141	231,0	47	55	400	11,00

Web: <http://cat.hansa-flex.com/en/HKCSTSC>

HK CSTS N

Pivot yoke with regreasable bearings

Standard: DIN 648, E SERIES, TYPE N
Application: Industry
Material: Steel ST 52.3

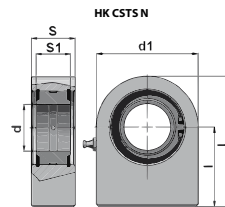

Note: HKCSTS09N00 cannot be re-lubricated

Identification	d	d1	l	L	S1	S	allowable dyn. load	Weight
	mm	mm	mm	mm	mm	mm	kN	kg
HK CSTS 016 N 00	16	48	35	59,0	14	18	21	0,29
HK CSTS 020 N 00	20	50	38	63,0	16	19	30	0,35
HK CSTS 025 N 00	25	55	45	72,5	20	23	48	0,53
HK CSTS 030 N 00	30	65	51	83,5	22	28	62	0,85
HK CSTS 035 N 00	35	83	61	102,5	25	30	80	1,50
HK CSTS 040 N 00	40	100	69	119,0	28	35	100	2,48
HK CSTS 045 N 00	45	110	77	132,0	32	40	127	3,45
HK CSTS 050 N 00	50	123	88	149,5	35	40	156	4,45
HK CSTS 060 N 00	60	140	100	170,0	44	50	245	7,10
HK CSTS 070 N 00	70	164	115	197,0	49	55	315	10,70
HK CSTS 080 N 00	80	180	141	231,0	55	60	400	15,10
HK CSTS 090 N 00	90	226	150	263,0	60	65	490	15,10

Web: <http://cat.hansa-flex.com/en/HKCSTSN>

HK WAPR

Pivot yoke with regreasable bearings



Design: clampable
Material: Steel ST 52.3

1

Ordering information: Further sizes and types of pivot bearing available on request.

Identification	d	d1	d2	d3	d4	F	i	L	L1	S1	S2	LF	S	allowable dyn. load	Weight
	mm	mm	mm	mm	mm		mm	mm	mm	mm	mm	mm	mm	kN	kg
HK WAPR 020 U	20	56	46	25	24	M 16x1.5	50	80	25	19	17	17	16	30	0,44
HK WAPR 025 U	25	56	46	25	29	M 16x1.5	50	80	28	23	21	17	20	48	0,47
HK WAPR 030 U	30	64	50	32	34	M 22x1.5	60	94	30	28	26	23	22	62	0,77
HK WAPR 035 U	35	78	66	40	40	M 28x1.5	70	112	38	30	28	29	25	80	1,24
HK WAPR 040 U	40	94	76	49	45	M 35x1.5	85	135	45	35	33	36	28	100	2,12
HK WAPR 050 U	50	110	90	61	56	M 45x1.5	105	168	55	40	37	46	35	156	3,74
HK WAPR 060 U	60	130	120	75	67	M 58x1.5	130	200	65	50	46	59	44	245	6,49
HK WAPR 070 U	70	154	130	86	79	M 65x1.5	150	232	75	55	51	66	49	315	9,80
HK WAPR 080 U	80	176	160	105	89	M 80x2	170	265	80	60	55	81	55	400	14,40
HK WAPR 090 U	90	206	180	124	98	M 100x2	210	322	90	65	60	101	60	490	23,50

HK WAPR

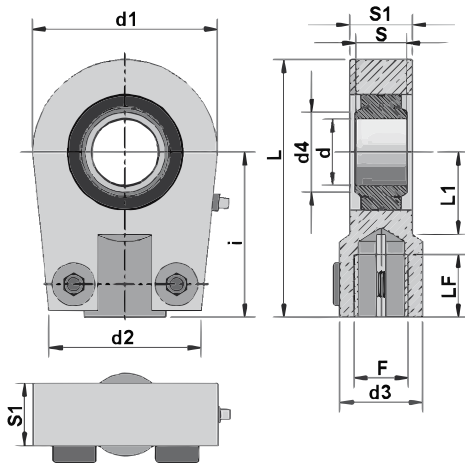

Web: <http://cat.hansa-flex.com/en/HKWAPR>

HK CGE
Radial pivot bearings GE

Standard: DIN 648, E SERIES - ISO 6124/1
Material: Steel

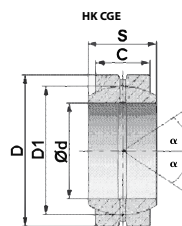

Identification	C mm	D mm	D1 mm	Ø d mm	S mm	α °	Weight kg
HK CGE 015 0000	9	26	22,0	15	12	8	0,03
HK CGE 020 0000	12	35	29,0	20	16	9	0,06
HK CGE 025 0000	16	42	35,5	25	20	7	0,11
HK CGE 030 0000	18	47	40,7	30	22	6	0,14
HK CGE 035 0000	20	55	47,0	35	25	6	0,22
HK CGE 040 0000	22	62	53,0	40	28	7	0,30
HK CGE 045 0000	25	68	60,0	45	32	7	0,40
HK CGE 050 0000	28	75	66,0	50	35	6	0,55
HK CGE 060 0000	36	90	80,0	60	44	6	1,00

Web: <http://cat.hansa-flex.com/en/HKCGE>

HK CAGEN
Ring for pivot bearing

Material: Steel ST 52.3 (FE 510)

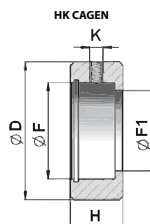

Identification	H mm	K	Ø D mm	Ø F mm	Ø F1 mm	Weight kg
HK CAGEN 040 150 15	15	M6	40	26	22	0,09
HK CAGEN 050 190 20	19	M6	50	35	29	0,15
HK CAGEN 060 230 25	23	M6	60	42	35	0,26
HK CAGEN 070 280 30	28	M6	70	47	40	0,47
HK CAGEN 085 300 35	30	M6	85	55	47	0,79
HK CAGEN 095 350 40	35	M8	95	62	53	1,14
HK CAGEN 110 400 45	40	M8	110	68	60	1,87
HK CAGEN 120 400 50	40	M8	120	75	66	2,18
HK CAGEN 138 500 60	50	M8	138	90	80	3,40

Web: <http://cat.hansa-flex.com/en/HKCAGEN>

HK CAGE

Ring for pivot bearing

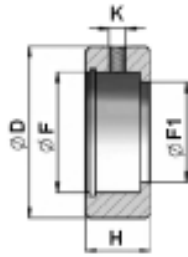

Material: Steel ST 52.3 (FE 510)

Identification	H mm	Ø D mm	Ø F mm	Weight kg
HK CAGE 040 026	11	40	26	0,06
HK CAGE 050 035	14	50	35	0,11
HK CAGE 069 042	19	69	42	0,34
HK CAGE 075 047	20	75	47	0,41
HK CAGE 080 055	22	80	55	0,45
HK CAGE 094 062	26	94	62	0,79

Web: <http://cat.hansa-flex.com/en/HKCAGE>

HK CPB

CPB swivel pin

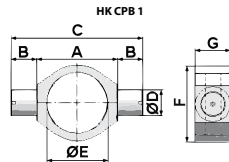

Material: Steel ST 52.3 (FE 510)

Note: Tolerance $\text{ØE} \leq 100$: +0.2; Tolerance $\text{ØE} > 100$: +0.4

Identification	A mm	B mm	C mm	F mm	G mm	Ø D mm	Ø E mm	Weight kg
HK CPB 035 1515	50	15	80	45	20	15	35	0,17
HK CPB 040 1515	50	15	80	50	20	15	40	0,16
HK CPB 042 2020	55	20	95	55	25	20	42	0,31
HK CPB 045 2020	60	20	100	60	25	20	45	0,36
HK CPB 010 0000	70	20	110	65	30	20	50	0,52
HK CPB 055 2020	75	20	115	70	30	20	55	0,52
HK CPB 020 0000	80	25	130	75	35	25	60	0,79
HK CPB 065 2525	90	25	140	85	35	25	65	0,95
HK CPB 030 0000	100	30	160	90	45	30	70	1,57
HK CPB 073 3030	100	30	160	95	45	30	73	1,60
HK CPB 075 3030	100	30	160	95	45	30	75	1,51
HK CPB 040 0000	110	35	180	100	50	35	80	2,35
HK CPB 090 3535	115	35	185	115	50	35	90	2,21
HK CPB 050 0000	115	40	195	115	55	40	92	2,60
HK CPB 050 1000	115	40	195	115	55	40	95	2,40
HK CPB 100 4040	120	40	200	120	55	40	100	2,46
HK CPB 055 0000	125	45	215	125	60	45	105	3,00
HK CPB 060 0000	145	50	245	145	70	50	115	5,30
HK CPB 125 5050	160	50	260	160	70	50	125	5,60
HK CPB 080 0000	170	60	290	170	80	60	140	7,70
HK CPB 145 6060	180	60	300	180	80	60	145	8,60
HK CPB 160 6060	200	60	320	200	100	60	160	12,80
HK CPB 170 7060	210	60	330	205	100	70	170	13,50
HK CPB 180 8060	230	60	350	225	105	80	180	18,30

Web: <http://cat.hansa-flex.com/en/HKCPB>

HK CSB

Ball joint fitting

Material: Steel C46

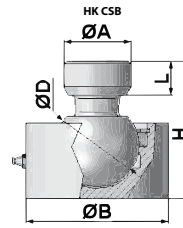

Identification	Ø A mm	Ø B mm	Ø D mm	H mm	L mm	Weight kg
HK CSB 050 0000	40	85	50	82	20	2,2
HK CSB 060 0000	50	98	60	100	25	3,4
HK CSB 070 0000	60	105	70	115	30	4,8

Web: <http://cat.hansa-flex.com/en/HKCSB>

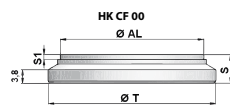
HK CF 00
Cylinder base

Material: Steel FE 510-A105

Note: These cylinder bases may bulge under pressure peaks. Weld on attachments to strengthen the bases. Use thicker cylinder bases (e.g. HK CFPM) for use in conditions with major pressure fluctuations or high operating cycles.

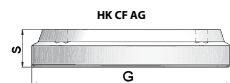
Identification	Ø AL mm	Ø T mm	S mm	S1 mm	Weight kg
HK CF 00 025 035	25	35	7	2	0,05
HK CF 00 030 040	30	40	8	2	0,06
HK CF 00 032 042	32	42	10	2	0,95
HK CF 00 035 045	35	45	10	2	0,10
HK CF 00 040 050	40	50	10	2	0,13
HK CF 00 045 055	45	55	10	2	0,16
HK CF 00 050 060	50	60	10	2	0,19
HK CF 00 055 065	55	65	12	2	0,28
HK CF 00 060 070	60	70	12	2	0,33
HK CF 00 063 073	63	73	12	2	0,35
HK CF 00 065 075	65	75	12	2	0,38
HK CF 00 065 080	65	80	12	2	0,40
HK CF 00 070 080	70	80	12	2	0,43
HK CF 00 070 085	70	85	12	2	0,45
HK CF 00 075 090	75	90	12	2	0,53
HK CF 00 080 090	80	90	12	2	0,55
HK CF 00 080 095	80	95	12	2	0,58
HK CF 00 085 100	85	100	15	2	0,77
HK CF 00 090 105	90	105	15	2	0,86
HK CF 00 100 115	100	115	15	2	1,05
HK CF 00 110 125	110	125	15	2	1,34
HK CF 00 110 130	110	130	15	2	1,40
HK CF 00 120 140	120	140	18	2	2,00
HK CF 00 125 145	125	145	18	2	2,11
HK CF 00 140 160	140	160	18	2	2,67
HK CF 00 150 170	150	170	20	2	3,33
HK CF 00 160 180	160	180	20	2	3,79

Web: <http://cat.hansa-flex.com/en/HKCF00>
HK CF (AG)
Cylinder base with outer thread

Material: Steel FE 510-A105

Note: These cylinder bases may bulge under pressure peaks. Weld on attachments to strengthen the bases. Use thicker cylinder bases (e.g. HK CFPM) for use in conditions with major pressure fluctuations or high operating cycles.

Identification	G	S mm	Weight kg
HK CF 00 180 185	M 185 x 2.5	35	6,85
HK CF 00 200 205	M 200 x 2.5	48	11,60
HK CF 00 220 228	M 228 x 2.5	48	14,50
HK CF 00 250 255	M 255 x 2.5	48	18,20
HK CF 00 300 308	M 308 x 3.0	60	33,00

Web: <http://cat.hansa-flex.com/en/HKCFAG>

HK CFPM

Cylinder base

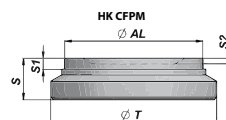
Material: Steel FE 510-A105

Identification	Ø AL mm	Ø T mm	S mm	S1 mm	S2 mm	Weight kg
HK CFPM 060 050 017	50	60	17	4	2	0,30
HK CFPM 065 050 017	50	65	17	4		0,36
HK CFPM 070 060 021	60	70	21	4		0,50
HK CFPM 075 060 019	60	75	19	4		0,56
HK CFPM 080 070 024	70	80	24	4		0,80
HK CFPM 085 070 022	70	85	22	4	2	0,85
HK CFPM 095 080 027	80	95	27	4		1,10
HK CFPM 100 080 025	80	100	25	4	2	1,30
HK CFPM 110 090 026	90	100	26	4		1,70
HK CFPM 115 100 033	100	115	33	4		2,20
HK CFPM 120 100 030	100	120	30	4	2	2,30
HK CFPM 125 110 036	110	125	36	7		2,90
HK CFPM 135 110 033	110	135	33	7		3,50
HK CFPM 140 120 040	120	140	40	7		3,80
HK CFPM 145 120 035	120	145	35	7		4,20
HK CFPM 170 140 040	140	170	40	7	2	6,40

Web: <http://cat.hansa-flex.com/en/HKCFPM>
HK CFHR

Cylinder base

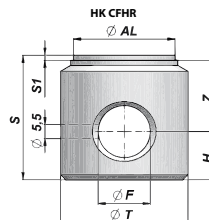
Material: Steel FE 510-A105
Use: Suitable for cylinder HK HFR

Identification	Ø AL mm	Ø F mm	Ø T mm	H mm	S mm	S1 mm	Z mm	Weight kg
HK CFHR 035 025	25	12,10	35	12	30	2	16	0,18
HK CFHR 040 032	32	16,00	40	17	40	2	21	0,32
HK CFHR 050 040	40	20,50	50	19	49	2	28	0,60
HK CFHR 060 050	50	25,50	60	25	70	2	43	1,28
HK CFHR 070 060	60	25,50	70	25	52	2	25	1,25
HK CFHR 080 070	70	30,50	80	25	62	2	35	1,94
HK CFHR 090 080	80	30,50	90	25	62	2	35	2,52
HK CFHR 115 100	100	30,50	115	34	70	2	34	4,90

Web: <http://cat.hansa-flex.com/en/HKCFHR>

HK CFHR2

Cylinder base

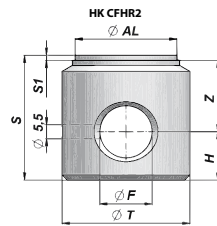

Material:
Use:

 Steel FE 510-A105
 Suitable for cylinder HK HFR 2S

Identification	Ø AL mm	Ø F mm	Ø T mm	H mm	S mm	S1 mm	Z mm	Weight kg
HK CFHR2 0350 160 35	35	16,10	45	15	35	2	20	0,3
HK CFHR2 0400 200 40	40	20,25	50	18	40	2	20	0,5
HK CFHR2 0450 200 45	45	20,25	55	20	45	2	25	0,7
HK CFHR2 0500 250 49	50	25,25	60	22	49	2	25	0,8
HK CFHR2 0550 250 50	55	25,25	65	22	50	2	28	1,0
HK CFHR2 0600 250 47	60	25,25	70	22	47	2	23	1,1
HK CFHR2 0600 300 47	60	30,25	70	22	47	2	25	1,0
HK CFHR2 0630 250 53	63	25,25	73	23	53	2	30	1,4
HK CFHR2 0630 300 53	63	30,25	73	23	53	2	30	1,3
HK CFHR2 0650 250 50	65	25,25	75	22	50	2	28	1,4
HK CFHR2 0700 300 63	70	30,25	80	28	63	2	33	2,1
HK CFHR2 0750 300 60	75	30,25	90	25	60	2	35	2,4
HK CFHR2 0800 300 60	80	30,25	90	28	60	2	30	2,4
HK CFHR2 0800 400 60	80	40,25	90	28	60	2	32	2,0
HK CFHR2 0850 350 63	85	35,25	100	28	63	2	35	3,0
HK CFHR2 0900 350 63	90	35,25	105	28	63	2	35	3,4
HK CFHR2 0900 400 63	90	40,25	105	28	63	2	35	3,2
HK CFHR2 1000 300 63	100	30,25	115	28	63	2	33	4,4
HK CFHR2 1000 400 63	100	40,25	115	28	63	2	35	3,9
HK CFHR2 1100 400 75	110	40,25	125	35	75	2	40	5,9
HK CFHR2 1100 500 75	110	50,50	125	35	75	2	40	5,2
HK CFHR2 1200 500 95	120	50,50	140	45	95	2	50	9,1
HK CFHR2 1200 600 95	120	60,50	140	45	95	2	50	8,2
HK CFHR2 1250 500 95	125	50,50	145	45	95	2	50	9,9
HK CFHR2 1250 600 95	125	60,50	145	45	95	2	50	8,9
HK CFHR2 1400 601 10	140	60,50	160	50	110	2	60	13,6
HK CFHR2 1400 701 10	140	70,50	160	50	110	2	60	12,4
HK CFHR2 1500 701 30	150	70,50	170	55	130	2	75	17,8
HK CFHR2 1600 801 40	160	80,50	180	65	140	2	75	20,7

Web: <http://cat.hansa-flex.com/en/HKCFHR2>
HK CF

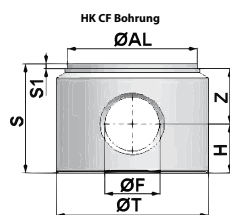
Cylinder base

Material:

Steel FE 510-A105

Identification	Ø AL mm	Ø F mm	Ø T mm	H mm	S mm	S1 mm	Z mm	Weight kg
HK CF 040 050 16	40	16,20	50	15,0	35	2	18,0	0,42
HK CF 050 060 20	50	20,25	60	20,0	45	2	23,0	0,80
HK CF 060 070 25	60	25,25	70	22,5	50	2	25,5	1,20
HK CF 070 080 25	70	25,25	80	22,5	50	2	25,5	1,60
HK CF 080 095 30	80	30,25	95	25,0	60	2	33,0	2,70
HK CF 100 115 35	100	35,25	115	30,0	70	2	38,0	4,70

Web: <http://cat.hansa-flex.com/en/HKCF>

HK CFHRT

Cylinder base

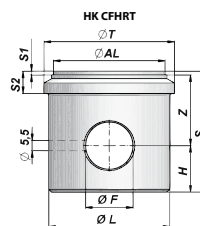
Material: Steel FE 510-A105

Identification	Ø AL mm	Ø F mm	Ø T mm	H mm	S mm	Ø L mm	S1 mm	Z mm	S2 mm	Weight kg
HK CFHRT 040 30	30	14,00	40	14	30		2	14		0,23
HK CFHRT 060 50	50	23,00	60	22	50		2	26		0,90
HK CFHRT 070 60	60	25,50	70	25	65	65	2	38	12	1,48

Web: <http://cat.hansa-flex.com/en/HKCFHRT>
HK CFVP

Cylinder base with oil inlet

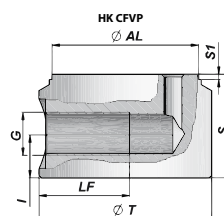
Material: Steel FE 510-A105

Identification	Ø AL mm	Ø T mm	G	I mm	LF mm	S mm	S1 mm	Weight kg
HK CFVP 040 050 04	40	50	G 1/4"	17,0	30	40	2	0,54
HK CFVP 050 060 06	50	60	G 3/8"	17,0	35	40	2	0,77
HK CFVP 060 070 06	60	70	G 3/8"	17,0	35	40	2	1,10
HK CFVP 063 073 06	63	73	G 3/8"	17,0	35	40	2	1,17
HK CFVP 070 080 06	70	80	G 3/8"	17,0	35	40	2	1,41
HK CFVP 080 095 08	80	95	G 1/2"	20,0	45	50	2	2,49
HK CFVP 090 105 08	90	105	G 1/2"	20,0	45	50	2	3,11
HK CFVP 100 115 08	100	115	G 1/2"	20,0	45	50	2	3,70

Web: <http://cat.hansa-flex.com/en/HKCFVP>
HK CFE

Cylinder base with oil inlet

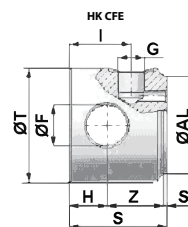
Material: Steel FE 510-A105

Identification	Ø AL mm	Ø F mm	Ø T mm	G	H mm	I mm	S mm	S1 mm	Z mm	Weight kg
HK CFE 040 050 4	40	16,20	50	G 1/4"	15	30,0	48	2	33	0,60
HK CFE 050 060 6	50	20,25	60	G 3/8"	20	38,0	58	2	38	1,10
HK CFE 060 070 6	60	25,25	70	G 3/8"	23	38,0	58	2	35	1,40
HK CFE 070 080 6	70	25,25	80	G 3/8"	23	38,0	58	2	35	1,95
HK CFE 080 095 8	80	30,25	95	G 1/2"	25	47,0	73	2	48	2,50
HK CFE 100 115 8	100	35,25	115	G 1/2"	30	47,0	73	2	43	4,50

Web: <http://cat.hansa-flex.com/en/HKCFE>

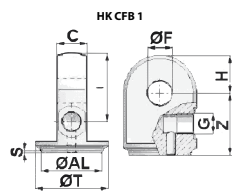
HK CFB**Hinged cylinder base with oil inlet****Material:**

Steel FE 510C

Identification	Ø AL mm	Ø F mm	Ø T mm	C mm	G	H mm	I mm	S mm	Z mm	Weight kg
HK CFB 040 050 4	40	16,20	50	24,8	G 1/4"	19,0	39,0	2,00	46	0,56
HK CFB 050 060 6	50	20,25	60	24,8	G 3/8"	31,0	56,0	2,00	51	0,84
HK CFB 060 070 6	60	25,25	70	24,8	G 3/8"	33,0	63,0	2,00	57	1,15
HK CFB 061 071 6	60	25,25	70	25,0	G 3/8"	29,5	48,0	2,00	47	0,81
HK CFB 070 080 6	70	25,25	80	39,5	G 3/8"	42,0	82,0	2,00	65	2,70

Web: <http://cat.hansa-flex.com/en/HKCFB>

HK CBS

Oil fitting

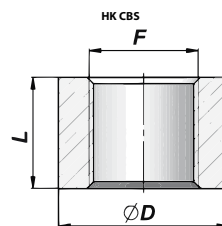
Material: Steel C22

Identification	F	L mm	Ø D mm	Weight kg
HK CBS 000 1215	M 12x1.5	14	20	0,03
HK CBS 000 1415	M 14x1.5	16	22	0,03
HK CBS 000 1615	M 16x1.5	17	26	0,04
HK CBS 000 1815	M 18x1.5	18	28	0,04
HK CBS 000 2015	M 20x1.5	18	30	0,06
HK CBS 000 2215	M 22x1.5	18	30	0,05
HK CBS 030 0000	G 1/8"	14	20	0,02
HK CBS 040 0000	G 1/4"	16	22	0,03
HK CBS 060 0000	G 3/8"	17	26	0,04
HK CBS 080 0000	G 1/2"	18	30	0,05
HK CBS 120 0000	G 3/4"	20	38	0,11
HK CBS 160 0000	G 1"	25	45	0,15
HK CBS 200 0000	G 1.1/4"	25	56	0,19
HK CBS 240 0000	G 1.1/2"	30	62	0,25
HK CBS NPT 000 0014	NPT 1/4"	15	26	0,03

Web: <http://cat.hansa-flex.com/en/HKCBS>
HK CBSP

Long oil fitting

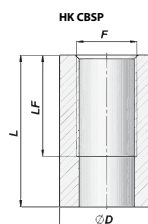
Material: Steel 9SMn28

Identification	F	L mm	LF mm	Ø D mm	Weight kg
HK CBSP 040 000	G 1/4"	40	27	22	0,05
HK CBSP 060 000	G 3/8"	42	28	26	0,06
HK CBSP 080 000	G 1/2"	48	33	30	0,07

Web: <http://cat.hansa-flex.com/en/HKCBSP>
HK CBSS

Oil fitting with bleeding

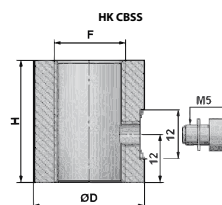
Material: Steel 9SMn28

Identification	F	H mm	Ø D mm	Weight kg
HK CBSS 04 30 M6	G 1/4"	30	22	0,06
HK CBSS 06 30 M6	G 3/8"	30	26	0,08
HK CBSS 08 30 M6	G 1/2"	30	30	0,10

Web: <http://cat.hansa-flex.com/en/HKCBSS>

HK CBSLT

Oil fitting for pipe connection

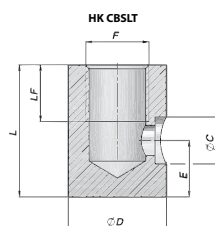

Material: Steel 95Mn28

Identification	E mm	F	L mm	LF mm	Ø C mm	Ø D mm	Weight kg
HK CBSLT 040 10	12	G 1/4"	30	15	10,5	22	0,07
HK CBSLT 060 12	15	G 3/8"	35	15	12,5	26	0,10
HK CBSLT 080 15	15	G 1/2"	35	15	15,5	30	0,13

Web: <http://cat.hansa-flex.com/en/HKCBSLT>

HK AXIAL

Axial oil fitting

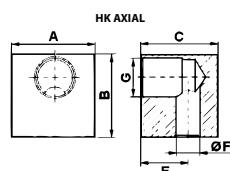

Material: Steel
Use: axial connector for hydraulic cylinders

Identification	A mm	B mm	C mm	E mm	G	Ø F mm	Weight kg
HK 092 AXIAL	25	25	30	14,0	G 1/4"	8	0,20
HK 093 AXIAL	30	30	30	15,0	G 3/8"	8	0,20
HK 094 AXIAL 1/2	35	35	40	24,5	G 1/2"	12	0,30
HK 098 AXIAL	30	30	30	17,0	M 16 x 1.5	8	0,30

Web: <http://cat.hansa-flex.com/en/HKAXIAL>

HK AX RU

Axial, round oil fitting

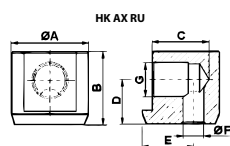

Material: Steel
Use: axial connector for hydraulic cylinders

Identification	Ø A mm	B mm	C mm	D mm	E mm	G	Ø F mm	Weight kg
HK 014 AX RU	30	28	22	17	20,0	G 1/4"	8	0,12
HK 038 AX RU	35	34	24	22	22,5	G 3/8"	8	0,20
HK 012 AX RU	45	47	30	31	27,5	G 1/2"	12	0,45
HK 034 AX RU	50	52	34	32	30,0	G 3/4"	14	0,58
HK 100 AX RU	60	62	42	39	35,0	G 1"	16	1,02

Web: <http://cat.hansa-flex.com/en/HKAXRU>

HK CGT

Guide housing for single-acting hydraulic cylinders 200 bar

Material: Cast steel UNI 5007-G26

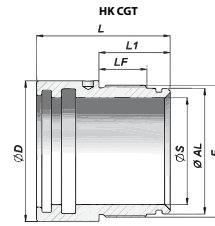

Identification	Ø A mm	Ø D mm	Ø S mm	F	L mm	L1 mm	LF mm	Weight kg	matching seal kit
HK CGT 020 0300	30	39	20	M 34x1.5	57	27	15	0,29	HK GKGT 020 030
HK CGT 025 0350	35	44	25	M 39x1.5	65	32	19	0,33	HK GKGT 025 035
HK CGT 030 0400	40	49	30	M 44x1.5	65	32	19	0,38	HK GKGT 030 040
HK CGT 035 0450	45	54	35	M 49x1.5	65	32	19	0,44	HK GKGT 035 045
HK CGT 040 0500	50	59	40	M 54x1.5	70	35	22	0,51	HK GKGT 040 050
HK CGT 045 0550	55	64	45	M 60x1.5	70	35	22	0,59	HK GKGT 045 055
HK CGT 050 0600	60	69	50	M 64x1.5	75	40	22	0,64	HK GKGT 050 060
HK CGT 060 0700	70	79	60	M 74x1.5	75	40	27	0,75	HK GKGT 060 070
HK CGT 070 0900	85	100	70	M 90x2	90	30	18	1,92	HK GKGT 070 000
HK CGT 080 0960	90	107	80	M 96x2	95	40	25	1,98	HK GKGT 080 000
HK CGT 100 1240	120	139	100	M 124x2	157	42	26	7,10	HK GKGT 100 000

Web: <http://cat.hansa-flex.com/en/HKCGT>

HK CG

Guide housing for double-acting hydraulic cylinders 200 bar

Material: Cast steel UNI 5007-G26, Aluminium for HKCG with ØS=16 mm

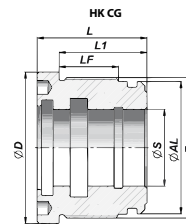

Identification	Ø A mm	Ø D mm	Ø S mm	F	L mm	LF mm	L1 mm	Weight kg	matching seal kit
HK CG 035 025 16	25	35	16	M 28x1.5	30	12		0,04	On request
HK CG 040 030 16	30	40	16	M 34x1.5	33	15	27	0,17	HK GKGO 030 016
HK CG 042 032 16	32	40	16	M 36x1.5	33	15	27	0,18	HK GKGO 032 016
HK CG 042 032 20	32	42	20	M 36x1.5	33	15	27	0,17	HK GKGO 032 020
HK CG 045 035 20	35	44	20	M 39x1.5	40	19	32	0,19	HK GKGO 035 020
HK CG 045 035 22	35	44	22	M 39x1.5	40	19	32	0,17	HK GKGO 035 022
HK CG 050 040 20	40	49	20	M 44x1.5	40	19	32	0,28	HK GKGO 040 020
HK CG 050 040 22	40	49	22	M 44x1.5	40	19	32	0,26	HK GKGO 040 022
HK CG 050 040 25	40	49	25	M 44x1.5	40	19	32	0,23	HK GKGO 040 025
HK CG 050 040 28	40	49	28	M 44x1.5	40	19	32	0,20	On request
HK CG 055 045 22	45	54	22	M 49x1.5	40	19	32	0,36	HK GKGO 045 022
HK CG 055 045 25	45	54	25	M 49x1.5	40	19	32	0,33	HK GKGO 045 025
HK CG 060 050 20	50	59	20	M 54x1.5	43	22	35	0,53	HK GKGO 050 020
HK CG 060 050 25	50	59	25	M 54x1.5	43	22	35	0,46	HK GKGO 050 025
HK CG 060 050 28	50	59	28	M 54x1.5	43	22	35	0,45	On request
HK CG 060 050 30	50	59	30	M 54x1.5	43	22	35	0,39	HK GKGO 050 030
HK CG 060 050 32	50	59	32	M 54x1.5	43	22	35	0,40	On request
HK CG 060 050 35	50	59	35	M 54x1.5	38	17	30	0,29	HK GKGO 050 035
HK CG 060 051 35	50	59	35	M 54x1.5	43	22	35	0,30	On request
HK CG 065 055 25	55	64	25	M 60x1.5	43	21	35	0,68	HK GKGO 055 025
HK CG 065 055 30	55	64	30	M 60x1.5	43	21	35	0,54	HK GKGO 055 030
HK CG 065 055 35	55	64	35	M 60x1.5	43	21	35	0,45	HK GKGO 055 035
HK CG 070 060 25	60	69	25	M 64x1.5	50	27	40	0,95	HK GKGO 060 025
HK CG 070 060 30	60	69	30	M 64x1.5	50	27	40	0,80	HK GKGO 060 030
HK CG 070 060 35	60	69	35	M 64x1.5	50	27	40	0,70	HK GKGO 060 035
HK CG 070 060 40	60	69	40	M 64x1.5	50	27	40	0,60	HK GKGO 060 040
HK CG 070 060 45	60	69	45	M 64x1.5	50	27	40	0,48	On request
HK CG 073 063 30	63	73	30	M 68x1.5	50	25	40	1,08	HK GKGO 063 030
HK CG 073 063 32	63	73	32	M 68x1.5	50	25	40	0,90	On request
HK CG 073 063 35	63	73	35	M 68x1.5	50	25	40	0,98	HK GKGO 063 035
HK CG 073 063 36	63	73	36	M 68x1.5	50	25	40	0,80	On request
HK CG 073 063 40	63	73	40	M 68x1.5	50	25	40	0,62	HK GKGO 063 040
HK CG 073 063 45	63	73	45	M 68x1.5	50	25	40	0,62	On request
HK CG 075 065 30	65	74	30	M 69x1.5	50	25	40	1,25	HK GKGO 065 030
HK CG 075 065 35	65	74	35	M 69x1.5	50	25	40	1,11	HK GKGO 065 035
HK CG 075 065 40	65	74	40	M 69x1.5	50	25	40	0,98	HK GKGO 065 040
HK CG 075 065 45	65	74	45	M 69x1.5	50	25	40	0,72	HK GKGO 065 045
HK CG 080 070 25	70	79	25	M 74x1.5	50	27	40	1,30	HK GKGO 070 025
HK CG 080 070 30	70	79	30	M 74x1.5	50	27	40	1,17	HK GKGO 070 030

HK CG

(Continued)

Guide housing for double-acting hydraulic cylinders 200 bar

Identification	Ø A mm	Ø D mm	Ø S mm	F	L mm	LF mm	L1 mm	Weight kg	matching seal kit
HK CG 080 070 35	70	79	35	M 74x1.5	50	27	40	1,06	HK GKG 070 035
HK CG 080 070 40	70	79	40	M 74x1.5	50	27	40	0,94	HK GKG 070 040
HK CG 080 070 45	70	79	45	M 74x1.5	50	27	40	0,76	HK GKG 070 045
HK CG 080 070 50	70	79	50	M 74x1.5	50	27	40	0,66	HK GKG 070 050
HK CG 090 075 30	75	89	30	M 80x2	60	33	50	1,72	HK GKG 075 030
HK CG 090 075 35	75	89	35	M 80x2	60	33	50	1,62	HK GKG 075 035
HK CG 090 075 40	75	89	40	M 80x2	60	33	50	1,46	HK GKG 075 040
HK CG 090 075 45	75	89	45	M 80x2	60	33	50	1,33	HK GKG 075 045
HK CG 095 080 30	80	94	30	M 85x2	60	33	50	2,25	HK GKG 080 030
HK CG 095 080 35	80	94	35	M 85x2	60	33	50	1,88	HK GKG 080 035
HK CG 095 080 40	80	94	40	M 85x2	60	33	50	1,73	HK GKG 080 040
HK CG 095 080 45	80	94	45	M 85x2	60	33	50	1,58	HK GKG 080 045
HK CG 095 080 50	80	94	50	M 85x2	60	33	50	1,42	HK GKG 080 050
HK CG 095 080 55	80	94	55	M 85x2	60	33	50	1,40	HK GKG 080 055
HK CG 095 080 60	80	94	60	M 85x2	60	33	50	1,38	HK GKG 080 060
HK CG 100 085 35	85	99	35	M 90x2	60	33	50	2,15	HK GKG 085 035
HK CG 100 085 40	85	99	40	M 90x2	60	33	50	2,00	HK GKG 085 040
HK CG 100 085 45	85	99	45	M 90x2	60	33	50	1,85	On request
HK CG 100 085 50	85	99	50	M 90x2	60	33	50	1,67	HK GKG 085 050
HK CG 105 090 40	90	104	40	M 95x2	60	33	50	2,31	HK GKG 090 040
HK CG 105 090 45	90	104	45	M 95x2	60	33	50	2,16	HK GKG 090 045
HK CG 105 090 50	90	104	50	M 95x2	60	33	50	1,99	HK GKG 090 050
HK CG 105 090 60	90	104	60	M 95x2	60	33	50	1,57	HK GKG 090 060
HK CG 115 100 40	100	114	40	M 105x2	82	51	70	4,14	HK GKG 100 040
HK CG 115 100 45	100	114	45	M 105x2	82	51	70	3,94	HK GKG 100 045
HK CG 115 100 50	100	114	50	M 105x2	82	51	70	3,71	HK GKG 100 050
HK CG 115 100 55	100	114	55	M 105x2	82	51	70	3,68	HK GKG 100 055
HK CG 115 100 60	100	114	60	M 105x2	82	51	70	3,13	HK GKG 100 060
HK CG 115 100 70	100	114	70	M 105x2	82	51	70	3,08	HK GKG 100 070
HK CG 125 110 45	110	124	45	M 115x2	72	41	60	4,60	HK GKG 110 045
HK CG 125 110 50	110	124	50	M 115x2	72	41	60	4,40	HK GKG 110 050
HK CG 125 110 60	110	124	60	M 115x2	82	51	70	4,90	HK GKG 110 060
HK CG 125 110 70	110	124	70	M 115x2	82	51	70	4,70	HK GKG 110 070
HK CG 140 120 50	120	139	50	M 125x2	82	49	70	6,37	HK GKG 120 050
HK CG 140 120 60	120	139	60	M 125x2	82	49	70	5,30	HK GKG 120 060
HK CG 140 120 70	120	139	70	M 125x2	82	49	70	4,57	HK GKG 120 070
HK CG 145 125 60	125	144	60	M 130x2	92	59	80	6,63	HK GKG 125 060
HK CG 145 125 70	125	144	70	M 130x2	92	59	80	5,83	HK GKG 125 070
HK CG 145 125 90	125	144	90	M 130x2	92	59	80	4,20	On request
HK CG 160 140 70	140	159	70	M 145x2	92	59	80	9,12	HK GKG 140 070
HK CG 160 140 80	140	159	80	M 145x2	92	59	80	8,40	HK GKG 140 080
HK CG 170 150 70	150	169	70	M 155x2	102	69	90	10,58	HK GKG 150 070
HK CG 170 150 80	150	169	80	M 155x2	102	69	90	9,75	HK GKG 150 080
HK CG 180 160 80	160	179	80	M 165x2	102	69	90	13,10	HK GKG 160 080
HK CG 180 160 90	160	179	90	M 165x2	102	69	90	12,07	HK GKG 160 090

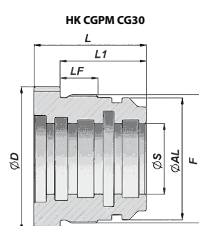
Web: <http://cat.hansa-flex.com/en/HKCG>
HK CGPM / CG30
Guide housing for double-acting hydraulic cylinders 250 bar

Material: Steel C40

Identification	Ø A mm	Ø D mm	Ø S mm	F	L mm	L1 mm	LF mm	Weight kg	matching seal kit
HK CGPM 065 050 025	50	64	25	M 54x1.5	55	45	22	0,66	HK GKG PM 050 025
HK CGPM 065 050 030	50	64	30	M 54x1.5	55	45	22	0,55	HK GKG PM 050 030
HK CGPM 065 050 035	50	64	35	M 54x1.5	55	45	22	0,41	HK GKG PM 050 035
HK CGPM 075 060 030	60	74	30	M 64x1.5	60	48	22	0,99	HK GKG PM 060 030
HK CGPM 075 060 035	60	74	35	M 64x1.5	60	48	22	0,86	HK GKG PM 060 035
HK CGPM 075 060 040	60	74	40	M 64x1.5	60	48	22	0,70	HK GKG PM 060 040
HK CGPM 080 063 035	63	78	35	M 68x1.5	60	48	22	1,04	On request
HK CGPM 080 063 040	63	78	40	M 68x1.5	60	48	22	0,88	On request
HK CGPM 085 070 035	70	84	35	M 74x1.5	65	50	22	1,48	On request
HK CGPM 085 070 040	70	85	40	M 74x1.5	65	50	22	1,27	HK GKG PM 070 040
HK CGPM 100 080 040	80	94	40	M 85x2	75	60	25	2,18	On request
HK CGPM 100 080 045	80	94	45	M 85x2	75	60	25	1,95	HK GKG PM 080 045
HK CGPM 100 080 050	80	95	50	M 85x2	75	60	25	1,70	HK GKG PM 080 050
HK CGPM 110 090 045	90	110	45	M 95x2	75	60	25	2,80	HK GKG PM 090 045
HK CGPM 110 090 050	90	110	50	M 95x2	75	60	25	2,57	HK GKG PM 090 050
HK CGPM 110 090 060	90	110	60	M 95x2	75	60	25	2,00	HK GKG PM 090 060
HK CGPM 120 100 045	100	120	45	M 105x2	75	60	25	3,80	HK GKG PM 100 045
HK CGPM 120 100 050	100	120	50	M 105x2	75	60	25	3,45	HK GKG PM 100 050
HK CGPM 120 100 060	100	120	60	M 105x2	75	60	25	2,90	HK GKG PM 100 060
HK CGPM 130 110 050	110	130	50	M 115x2	85	70	30	5,00	HK GKG PM 110 050

(Continued)

HK CGPM / CG30

Guide housing for double-acting hydraulic cylinders 250 bar

Identification	Ø A mm	Ø D mm	Ø S mm	F	L mm	L1 mm	LF mm	Weight kg	matching seal kit
HK CGPM 130 110 060	110	130	60	M 115x2	85	70	30	4,42	HK GKG PM 110 060
HK CGPM 140 120 060	120	140	60	M 125x2	85	70	30	5,70	HK GKG PM 120 060
HK CGPM 140 120 070	120	140	70	M 125x2	85	70	30	4,90	HK GKG PM 120 070
HK CGPM 140 120 080	120	140	80	M 125x2	85	70	30	3,96	HK GKG PM 120 080
HK CGPM 145 125 070	125	144	70	M 130x2	90	75	40	5,99	HK GKG PM 125 070
HK CGPM 145 125 080	125	144	80	M 130x2	90	75	40	4,95	HK GKG PM 125 080
HK CGPM 160 140 080	140	160	80	M 145x2	90	75	40	7,20	HK GKG PM 140 080
HK CGPM 160 140 090	140	159	90	M 145x2	90	75	40	6,21	HK GKG PM 140 090
HK CGPM 160 140 100	140	160	100	M 145x2	90	75	40	5,00	HK GKG PM 140 100
HK CGPM 170 150 080	150	169	80	M 155x2	100	85	46	9,85	HK GKG PM 150 080
HK CGPM 170 150 090	150	169	90	M 155x2	100	85	46	8,73	HK GKG PM 150 090
HK CGPM 170 150 100	150	169	100	M 155x2	100	85	46	7,49	HK GKG PM 150 100
HK CGPM 180 160 100	160	180	100	M 165x2	100	85	46	9,40	HK GKG PM 160 100
HK CGPM 180 160 120	160	180	120	M 165x2	100	85	46	6,40	HK GKG PM 160 120
HK CG 30 180 100	180	210	100	M 188x2.5	110	92	58	15,80	On request
HK CGPM 215 180 100	180	215	100	M 188x2.5	125	107	60	18,10	HK GKG PM 180 100
HK CGPM 215 180 120	180	215	120	M 188x2.5	125	107	60	14,35	HK GKG PM 180 120
HK CG 30 200 100	200	218	100	M 208x2.5	110	92	58	20,60	On request
HK CGPM 225 200 100	200	225	100	M 208x2.5	125	107	60	23,61	HK GKG PM 200 100
HK CGPM 225 200 120	200	225	120	M 208x2.5	125	107	60	19,90	HK GKG PM 200 120
HK CGPM 225 200 140	200	225	140	M 208x2.5	125	107	60	16,03	HK GKG PM 200 140
HK CGPM 245 220 120	220	245	120	M 228x2.5	130	112	65	27,82	HK GKG PM 220 120
HK CGPM 245 220 140	220	245	140	M 228x2.5	130	112	65	23,80	HK GKG PM 220 140
HK CG 30 250 120	250	268	120	M 258x2.5	135	117	80	40,00	On request
HK CGPM 275 250 150	250	275	150	M 258x2.5	150	130	80	37,42	HK GKG PM 250 150
HK CGPM 275 250 180	250	275	180	M 258x2.5	150	130	80	27,73	HK GKG PM 250 180
HK CGPM 335 300 150	300	335	150	M 308x3	180	155	95	77,10	HK GKG PM 300 150
HK CGPM 335 300 180	300	335	180	M 308x3	180	155	95	65,50	HK GKG PM 300 180

Web: <http://cat.hansa-flex.com/en/HKCGPMCG30>

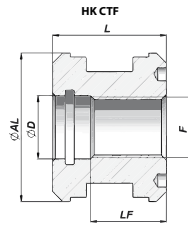
HK CTF**Threaded piston for hydraulic cylinders****Material:** Steel 9SMn28**Note:** Suitable packing sets can be supplied on request.

Identification	Ø AL mm	Ø D mm	F	L mm	LF mm	Weight kg
HK CTF 25 101 25	25	11,1	M 10x1.5	25	18	0,10
HK CTF 040 16 15	40	17,1	M 16x1.5	40	30	0,22
HK CTF 050 20 15	50	21,1	M 20x1.5	40	28	0,31
HK CTF 060 24 20	60	25,1	M 24x2	45	30	0,07
HK CTF 063 24 20	63	25,1	M 24x2	45	30	0,66
HK CTF 070 24 20	70	25,1	M 24x2	45	30	0,78
HK CTF 080 27 20	80	28,1	M 27x2	45	30	1,08
HK CTF 090 33 20	90	35,1	M 33x2	50	35	1,60
HK CTF 100 33 20	100	35,1	M 33x2	50	35	2,18
HK CTF 110 39 30	110	42,0	M 39x3	50	35	2,40
HK CTF 120 42 30	120	45,0	M 42x3	50	35	3,00
HK CTF 125 42 30	125	45,0	M 42x3	50	35	3,20
HK CTF 140 48 30	140	51,0	M 48x3	58	40	4,90
HK CTF 150 48 30	150	51,0	M 48x3	58	40	5,80
HK CTF 160 52 30	160	54,0	M 52x3	58	40	6,70

Material aluminium for HK CTF 25 101 25

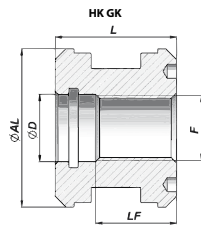
Web: <http://cat.hansa-flex.com/en/HKCTF>**HK GK****Threaded piston for hydraulic cylinders****Material:** Steel 9SMn28**Note:** Suitable packing sets can be supplied on request.

Identification	Ø AL mm	Ø D mm	F	L mm	LF mm	Weight kg
HK GK 32 1415 K	32	15,0	M 14x1.5	30	10	0,20

Web: <http://cat.hansa-flex.com/en/HK GK>

HK CTBF
Short threaded piston for hydraulic cylinders

Material: Steel 95Mn28
Use: Suitable for cylinder HK HFR 2S

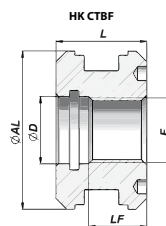

Note: Suitable packing sets can be supplied on request.

Identification	Ø AL mm	Ø D mm	F	L mm	LF mm	Weight kg
HK CTBF 060 M24	60	25,1	M 24x2	35	24	0,45
HK CTBF 070 M24	70	25,1	M 24x2	35	24	0,70
HK CTBF 080 M27	80	28,1	M 27x2	40	26	1,10
HK CTBF 100 M33	100	35,1	M 33x2	40	26	1,80

Web: <http://cat.hansa-flex.com/en/HKCTBF>

HK CTPM
Threaded piston for hydraulic cylinders

Material: Steel C40

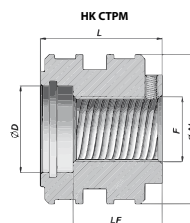

Identification	Ø AL mm	Ø D mm	F	L mm	LF mm	Weight kg	matching seal kit
HK CTPM 050 021 040	50	21,0	M 20x1.5	40	28	0,4	HK GKG CTPM 050
HK CTPM 050 025 040	50	25,0	M 22x1.5	40	28	0,4	On request
HK CTPM 060 030 045	60	30,0	M 27x2	45	30	0,6	HK GKG CTPM 060
HK CTPM 063 030 045	63	30,0	M 27x2	45	30	0,7	On request
HK CTPM 070 035 056	70	35,0	M 33x2	56	41	1,0	On request
HK CTPM 070 040 056	70	40,0	M 30x2	56	41	1,0	HK GKG CTPM 070
HK CTPM 080 040 056	80	40,0	M 30x2	56	41	1,4	HK GKG CTPM 080
HK CTPM 080 041 056	80	40,0	M 33x2	41	56	1,4	On request
HK CTPM 090 038 055	90	38,0	M 36x3	55	40	1,8	HK GKG CTPM 090
HK CTPM 090 043 055	90	43,0	M 40x2	55	47	1,7	HK GKG CTPM 090
HK CTPM 100 045 056	100	45,0	M 42x2	56	41	2,2	HK GKG CTPM 100
HK CTPM 110 050 070	110	50,0	M 48x3	70	55	3,4	HK GKG CTPM 110
HK CTPM 120 050 070	120	50,0	M 48x3	70	55	4,1	HK GKG CTPM 120
HK CTPM 120 054 070	120	54,0	M 52x2	70	55	3,9	On request
HK CTPM 125 050 070	125	51,0	M 48x3	70	55	4,4	HK GKG CTPM 125
HK CTPM 125 054 070	125	54,0	M 52x2	70	57	4,2	HK GKG CTPM 125
HK CTPM 140 050 075	140	50,0	M 48x3	75	57	6,0	HK GKG CTPM 140
HK CTPM 140 067 075	140	67,0	M 64x3	75	61	5,6	On request
HK CTPM 150 056 080	150	56,0	M 52x3	80	60	7,5	HK GKG CTPM 150
HK CTPM 150 067 080	150	67,0	M 64x3	80	64	6,9	On request
HK CTPM 160 056 080	160	56,0	M 52x3	80	60	8,5	HK GKG CTPM 160
HK CTPM 160 076 080	160	76,0	M 74x3	80	64	7,8	On request
HK CTPM 180 090 115	180	90,0	M 80x2	115	85	14,1	HK GKG CTPM 180
HK CTPM 200 100 115	200	100,0	M 90x2	115	85	17,5	HK GKG CTPM 200
HK CTPM 220 110 120	220	110,0	M 100x2	120	90	21,8	HK GKG CTPM 220
HK CTPM 250 125 130	250	125,0	M 115x3	130	100	30,1	HK GKG CTPM 250
HK CTPM 300 150 140	300	150,0	M 140x3	140	105	44,9	HK GKG CTPM 300

Web: <http://cat.hansa-flex.com/en/HKCTPM>

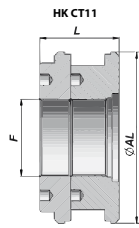
HK CT11
Threaded piston for hydraulic cylinders

Material: Steel 9SMn28

Note: Suitable packing sets can be supplied on request.

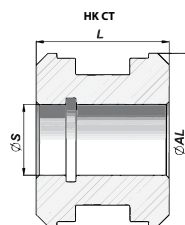
Identification	Ø AL mm	F	L mm	Weight kg
HK CT11 180 080	180	M 80x2	82	9,75
HK CT11 200 080	200	M 80x2	82	13,00
HK CT11 250 080	250	M 98x2	82	21,60

Web: <http://cat.hansa-flex.com/en/HKCT11>
HK CT
Inserted piston for hydraulic cylinders

Material: Steel 9SMn28

Identification	Ø AL mm	Ø S mm	L mm	Weight kg	matching seal kit
HK CT 00 030 013	30	13	25	0,02	HK GKG0 030 016
HK CT 00 032 013	32	13	30	0,09	HK GKG0 032 016
HK CT 00 032 015	32	15	30	0,09	HK GKG0 032 020
HK CT 00 035 015	35	15	40	0,16	HK GKG0 035 020
HK CT 00 040 015	40	15	40	0,23	HK GKG0 040 020
HK CT 00 045 015	45	15	40	0,31	HK GKG0 045 022
HK CT 00 050 015	50	15	40	0,31	HK GKG0 050 020
HK CT 00 050 020	50	20	40	0,35	HK GKG0 050 030
HK CT 00 055 020	55	20	40	0,42	HK GKG0 055 025
HK CT 00 060 020	60	20	50	0,71	HK GKG0 060 025
HK CT 00 060 024	60	24	45	0,56	HK GKG0 060 030
HK CT 00 060 027	60	27	50	0,61	HK GKG0 060 035
HK CT 00 063 020	63	20	50	0,70	HK GKG0 063 030
HK CT 00 063 024	63	24	45	0,65	HK GKG0 063 035
HK CT 00 065 020	65	20	50	0,88	HK GKG0 065 030
HK CT 00 065 024	65	24	45	0,72	HK GKG0 065 035
HK CT 00 070 020	70	20	50	0,81	HK GKG0 070 025
HK CT 00 070 024	70	24	45	0,76	HK GKG0 070 030
HK CT 00 070 027	70	27	50	0,71	HK GKG0 070 035
HK CT 00 075 024	75	24	45	0,93	HK GKG0 075 030
HK CT 00 075 027	75	27	50	1,00	HK GKG0 075 035
HK CT 00 080 024	80	24	45	1,11	HK GKG0 080 030
HK CT 00 080 027	80	27	50	1,23	HK GKG0 080 035
HK CT 00 085 024	85	24	45	1,30	HK GKG0 085 035
HK CT 00 085 027	85	27	50	1,43	HK GKG0 085 040
HK CT 00 090 027	90	27	50	1,66	HK GKG0 090 040
HK CT 00 090 033	90	33	50	1,55	HK GKG0 090 045
HK CT 00 100 027	100	27	50	2,06	HK GKG0 100 040
HK CT 00 100 033	100	33	50	1,95	HK GKG0 100 045
HK CT 00 110 033	110	33	50	2,49	HK GKG0 110 045
HK CT 00 110 040	110	40	50	2,33	HK GKG0 110 050
HK CT 00 120 040	120	40	50	2,95	HK GKG0 120 050
HK CT 00 125 040	125	40	50	3,24	HK GKG0 125 060
HK CT 00 140 040	140	40	58	5,04	HK GKG0 140 070
HK CT 00 150 040	150	40	58	5,67	HK GKG0 150 070
HK CT 00 160 051	160	51	58	6,60	HK GKG0 160 080

Material aluminium for HK CT 00 030 013

Web: <http://cat.hansa-flex.com/en/HKCT>

HK CTLM

Inserted piston for hydraulic cylinders

Material: Steel 9SMn28

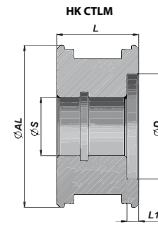

Note: Suitable packing sets can be supplied on request.

Identification	Ø AL mm	Ø D mm	Ø S mm	L mm	L1 mm	Weight kg
HK CTLM 040 015 027	40	27,0	15	27	5	0,15
HK CTLM 050 021 030	50	36,0	21	30	5	0,25

Web: <http://cat.hansa-flex.com/en/HKCTLM>

HK CTB

Short inserted piston for hydraulic cylinders

Material: Steel 9SMn28

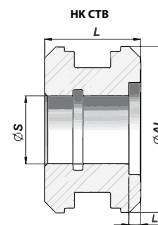

Note: Suitable packing sets can be supplied on request.

Identification	Ø AL mm	Ø S mm	L mm	L1 mm	Weight kg
HK CTB 0 040 015	40	15	27	3	0,14
HK CTB 0 050 020	50	20	30	3	0,20
HK CTB 0 060 020	60	20	35	5	0,35
HK CTB 0 060 024	60	24	35	5	0,42
HK CTB 0 070 020	70	20	35	5	0,58
HK CTB 0 070 024	70	24	35	5	0,67
HK CTB 0 080 024	80	24	40	5	1,08
HK CTB 0 080 027	80	27	40	5	1,03
HK CTB 0 100 027	100	27	40	5	1,83
HK CTB 0 100 033	100	33	40	5	1,72

Web: <http://cat.hansa-flex.com/en/HKCTB>

HK CA

Inserted piston without plunger cylinder guide

Material: Steel ST 52.3 (FE 510)

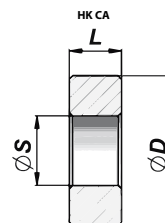

Identification	Ø D mm	Ø S mm	L mm	Weight kg
HK CA 35	34,0	15	10	0,06
HK CA 40	38,0	20	15	0,10
HK CA 45	43,0	20	15	0,13
HK CA 50	48,0	20	20	0,23
HK CA 60	58,0	27	20	0,32
HK CA 70	68,0	27	20	0,48

Web: <http://cat.hansa-flex.com/en/HKCA>

HK CAT

Clamping ring for plunger cylinder

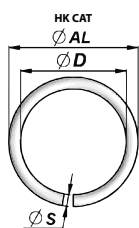

Material: Steel ST 52.3 (FE 510)

Identification	Ø AL mm	Ø D mm	Ø S mm	Weight kg
HK CAT 25	28	22,0	3	0,01
HK CAT 30	33	27,0	3	0,01
HK CAT 35	38	31,5	3	0,01
HK CAT 40	44	36,0	4	0,01
HK CAT 45	49	41,0	4	0,01
HK CAT 50	54	45,5	4	0,09
HK CAT 60	65	54,5	5	0,03

Web: <http://cat.hansa-flex.com/en/HKCAT>

HK PF

Inserted piston with plunger cylinder guide

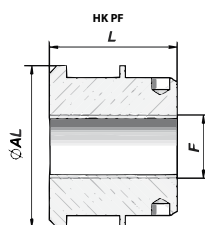

Material: Steel 9SMn28

Note: Suitable packing sets can be supplied on request.

Identification	Ø AL mm	F	L mm	Weight kg
HK PF 25	35	M 14x1.5	30	1,0
HK PF 30	40	M 20x1.5	30	1,0
HK PF 35	45	M 20x1.5	30	1,0
HK PF 40	50	M 20x1.5	30	1,0
HK PF 45	55	M 27x1.5	30	1,0
HK PF 50	60	M 27x1.5	30	1,0
HK PF 55	65	M 27x1.5	30	1,0
HK PF 60	70	M 27x1.5	30	1,0
HK PF 70	80	M 33x1.5	30	1,5
HK PF 80	90	M 42x1.5	30	1,5
HK PF 8048 15	90	M 48x1.5	30	1,6
HK PF 100	110	M 48x1.5	30	1,9
HK PF 100-1	120	M 48x1.5	30	2,5

Web: <http://cat.hansa-flex.com/en/HKPF>

Accessories:

HK FR - Guide ring for inserted piston PF

Guide ring for inserted piston PF

Material: POM



1

Identification	for pistons	Weight kg
HK FR 31 35	Inserted piston 25/35	0,01
HK FR 36 40	Inserted piston 30/40	0,01
HK FR 41 45	Inserted piston 35/45	0,01
HK FR 44 50	Inserted piston 40/50	0,01
HK FR 50 55 1	Inserted piston 45/55	0,01
HK FR 54 60	Inserted piston 50/60	0,01
HK FR 59 65	Inserted piston 55/65	0,01
HK FR 64 70	Inserted piston 60/70	0,01
HK FR 74 80 2	Inserted piston 70/80	0,01
HK FR 84 90	Inserted piston 80/90	0,01
HK FR 104 110	Inserted piston 110	0,01
HK FR 114 120	Inserted piston 120	0,01

Web: <http://cat.hansa-flex.com/en/HKFR>

Accessory for following products:

HK PF - Inserted piston with plunger cylinder guide

HK FAC**Chrome-plated piston rod**

Design: Piston rods - metre goods, Tolerance f7
Material: Steel 20MnV6, chrome 25 µm ± 5
Surface: Chrome layer 25µm +5µm, Surface hardness HRC 66-69 (HV 850-1000), Roughness Ra ≤ 0.2µm, Corrosion resistance up to 120 hours in NSS test according to ISO 3768 / Rating 9

Note: Limited suitability for operating conditions with high levels of soiling (e.g. tail lifts etc.)
 Further dimensions, see HK FAC HC2

Ordering information: Max. production length 6.00 m
 Other designs available on request

Identification	Ø S mm	Weight / meter kg
HK FAC 012 L000	12	0,91
HK FAC 250 L000	250	385,30
HK FAC 300 L000	300	493,00

Ø S = piston rod diameter

Web: <http://cat.hansa-flex.com/en/HKFAC>

HK FAC HC2**Chrome-plated piston rod HC 200**

Design: Piston rods - metre goods, Tolerance f7
Material: Steel 20MnV6
Surface: Chrome layer 25µm +5µm, Surface hardness HRC 66-69 (HV 850-1000), Roughness Ra ≤ 0.2µm, Corrosion resistance up to 200 hours in NSS test according to ISO 3768 / Rating 9

Note: Limited suitability for operating conditions with high levels of soiling (e.g. tail lifts etc.)

Ordering information: Max. production length 6.00 m
 Other designs available on request

Identification	Ø S mm	Weight / meter kg
HK FAC 016 HC2 L000	16	1,58
HK FAC 018 HC2 L000	18	2,00
HK FAC 020 HC2 L000	20	2,47
HK FAC 022 HC2 L000	22	2,99
HK FAC 025 HC2 L000	25	3,86
HK FAC 028 HC2 L000	28	4,84
HK FAC 030 HC2 L000	30	5,56
HK FAC 032 HC2 L000	32	6,32
HK FAC 035 HC2 L000	35	7,56
HK FAC 036 HC2 L000	36	8,00
HK FAC 040 HC2 L000	40	9,88
HK FAC 042 HC2 L000	42	10,86
HK FAC 045 HC2 L000	45	12,50
HK FAC 050 HC2 L000	50	15,43
HK FAC 055 HC2 L000	55	18,67
HK FAC 056 HC2 L000	56	19,36
HK FAC 060 HC2 L000	60	22,22
HK FAC 063 HC2 L000	63	24,50
HK FAC 070 HC2 L000	70	34,72
HK FAC 080 HC2 L000	80	39,51
HK FAC 090 HC2 L000	90	50,00
HK FAC 100 HC2 L000	100	61,73
HK FAC 110 HC2 L000	110	74,70
HK FAC 120 HC2 L000	120	88,89
HK FAC 140 HC2 L000	140	121,00

Ø S = piston rod diameter

Web: <http://cat.hansa-flex.com/en/HKFACHC2>

HK FAC HC5

Chrome-plated piston rod HC 500

Design: Piston rods - metre goods, Tolerance f7
Material: Steel 20MnV6
Surface: Chrome double layer 2 x 20µm +-5µm, Surface hardness HRC 66-69 (HV 850-1000), Roughness Ra ≤ 0.2µm, Corrosion resistance up to 500 hours in NSS test according to ISO 3768 / Rating 9



Note: These materials are only ordered on request and are not available from stock.

Ordering information: Max. production length 6.00 m
 Other designs available on request

Identification	Ø S mm	Weight / meter kg
HK FAC 020 HC5 L000	20	2,47
HK FAC 025 HC5 L000	25	3,90
HK FAC 028 HC5 L000	28	4,90
HK FAC 030 HC5 L000	30	5,60
HK FAC 035 HC5 L000	35	7,60
HK FAC 036 HC5 L000	36	8,10
HK FAC 040 HC5 L000	40	9,90
HK FAC 045 HC5 L000	45	12,55
HK FAC 050 HC5 L000	50	15,50
HK FAC 060 HC5 L000	60	22,30
HK FAC 070 HC5 L000	70	34,80
HK FAC 080 HC5 L000	80	39,60
HK FAC 090 HC5 L000	90	50,00
HK FAC 100 HC5 L000	100	61,70

Ø S = piston rod diameter

Web: <http://cat.hansa-flex.com/en/HKFACHC5>

HK FAC CRNI

Chrome-plated piston rod CRNI

Design: Piston rods - metre goods, Tolerance f7
Material: Steel 20MNV6CRNI
Surface: Nickel layer 30µm, chrome layer 20µm, Surface hardness, nickel coating HV 300, Surface hardness, chrome coating HV 850, Roughness Ra ≤ 0.2µm, Corrosion resistance up to 1000 hours in NSS test according to ISO 3768 / Rating 9



Ordering information: Max. production length 6.00 m
 Other designs available on request

Identification	Ø S mm	Weight / meter kg
HK FAC 020 CRNI L000	20	2,50
HK FAC 025 CRNI L000	25	3,89
HK FAC 028 CRNI L000	28	4,72
HK FAC 030 CRNI L000	30	5,56
HK FAC 035 CRNI L000	35	7,50
HK FAC 036 CRNI L000	36	8,10
HK FAC 040 CRNI L000	40	10,00
HK FAC 045 CRNI L000	45	12,50
HK FAC 050 CRNI L000	50	15,56
HK FAC 060 CRNI L000	60	22,22
HK FAC 070 CRNI L000	70	30,28
HK FAC 080 CRNI L000	80	39,44
HK FAC 090 CRNI L000	90	50,56
HK FAC 100 CRNI L000	100	61,67

Ø S = piston rod diameter

Web: <http://cat.hansa-flex.com/en/HKFACCRNI>

HK FT

Cylinder barrel



Design: Cylinder barrel - metre goods, HP: peeled and roller burnished, tolerance H8, HPS: cold-drawn, tolerance H9

Material: HP: ST 52.0 EN 10305-1 (E355+SR) seamless, HPS: ST 52.0 EN 10305-2 (E355+C) welded

Ordering information: Max. production length 6.00 m
Other designs available on request

Identification	Design	Ø A mm	Ø l mm	Weight / meter kg
HK FT 030 020 00	HPS	30	20	3,08
HK FT 035 025 00	HPS	35	25	3,70
HK FT 040 030 00	HPS	40	30	4,32
HK FT 042 032 00	HPS	42	32	4,56
HK FT 045 035 00	HPS	45	35	4,93
HK FT 050 040 00	HPS	50	40	5,55
HK FT 055 045 00	HPS	55	45	6,17
HK FT 060 040 00	HP	60	40	12,33
HK FT 060 050 00	HPS	60	50	6,78
HK FT 062 050 00	HPS	62	50	8,29
HK FT 065 050 00	HPS	65	50	10,63
HK FT 065 055 00	HPS	65	55	7,40
HK FT 070 050 00	HP	70	50	14,80
HK FT 070 055 00	HPS	70	55	11,56
HK FT 070 060 00	HPS	70	60	8,01
HK FT 073 063 00	HP	73	63	8,38
HK FT 078 063 00	HP	78	63	13,04
HK FT 075 060 00	HPS	75	60	12,48
HK FT 075 063 00	HPS	75	63	10,21
HK FT 075 065 00	HPS	75	65	8,63
HK FT 080 060 00	HP	80	60	17,26
HK FT 080 065 00	HP	80	65	13,41
HK FT 080 070 00	HPS	80	70	9,25
HK FT 082 070 00	HPS	82	70	10,25
HK FT 083 063 00	HP	83	63	18,00
HK FT 085 070 00	HPS	85	70	14,33
HK FT 085 075 00	HPS	85	75	9,86
HK FT 090 070 00	HP	90	70	19,73
HK FT 090 075 00	HP	90	75	15,26
HK FT 090 080 00	HPS	90	80	10,48
HK FT 092 080 00	HPS	92	80	12,72
HK FT 095 080 00	HPS	95	80	16,18
HK FT 095 085 00	HP	95	85	13,50
HK FT 100 080 00	HP	100	80	22,20
HK FT 100 085 00	HP	100	85	17,11
HK FT 100 090 00	HP	100	90	11,71
HK FT 102 090 00	HPS	102	90	14,21
HK FT 105 090 00	HP	105	90	18,03
HK FT 110 090 00	HP	110	90	24,66
HK FT 115 100 00	HP	115	100	19,88
HK FT 120 100 00	HP	120	100	27,15
HK FT 125 110 00	HP	125	110	21,73
HK FT 130 110 00	HP	130	110	29,59
HK FT 130 115 00	HP	130	115	22,68
HK FT 135 110 00	HP	135	110	37,76
HK FT 140 120 00	HP	140	120	32,06
HK FT 145 120 00	HP	145	120	41,50
HK FT 145 125 00	HP	145	125	33,29
HK FT 150 125 00	HP	150	125	42,39
HK FT 160 140 00	HP	160	140	36,99
HK FT 170 140 00	HP	170	140	57,34
HK FT 170 150 00	HP	170	150	39,46
HK FT 180 150 00	HP	180	150	61,03
HK FT 180 160 00	HP	180	160	39,46
HK FT 190 160 00	HP	190	160	64,73
HK FT 195 160 00	HP	195	160	76,60
HK FT 210 180 00	HP	210	180	72,10
HK FT 220 180 00	HP	220	180	98,64
HK FT 230 200 00	HP	230	200	79,53
HK FT 240 200 00	HP	240	200	84,50
HK FT 280 250 00	HP	280	250	98,30
HK FT 323 250 00	HP	324	250	261,00

Ø A = external diameter Ø l = Inner diameter

Web: <http://cat.hansa-flex.com/en/HKFT>

HK ASEP
Vent screws

Material: Brass, Sinter bronze filter
Use: For venting plunger cylinders

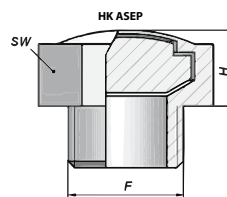

Identification	F	H mm	AF mm	Weight kg
HK ASEP 03 0000	G 1/8"	13,0	13	0,01
HK ASEP 04 0000	G 1/4"	16,0	16	0,01
HK ASEP 06 0000	G 3/8"	18,0	19	0,02
HK ASEP 08 0000	G 1/2"	20,0	24	0,02
HK ASEP 12 0000	G 3/4"	24,0	30	0,04
HK ASEP 16 0000	G 1"	27,0	36	0,06

Web: <http://cat.hansa-flex.com/en/HKASEP>

HK CDA
Piston protection nut, self-locking

Material: Steel

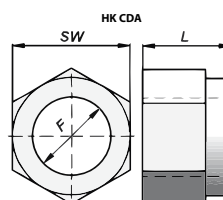

Identification	F	L mm	AF mm	Weight kg
HK CDA 000 1415	M 14x1.5	16	22	0,03
HK CDA 000 2015	M 20x1.5	23	30	0,07
HK CDA 000 2420	M 24x2	27	36	0,13
HK CDA 000 2720	M 27x2	30	41	0,18
HK CDA 000 3320	M 33x2	35	50	0,31
HK CDA 000 3930	M 39x3	42	60	0,56
HK CDA 000 4830	M 48x3	49	75	1,00

Web: <http://cat.hansa-flex.com/en/HKCDA>

HK CDB
Piston protection nut, self-locking, flat-headed

Material: Steel

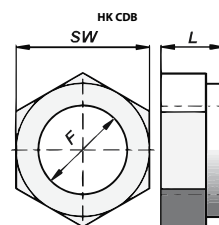

Identification	F	L mm	AF mm	Weight kg
HK CDB 000 2015	M 20x1.5	18	30	0,06
HK CDB 000 2420	M 24x2	21	36	0,10
HK CDB 000 2720	M 27x2	23	41	0,18

Web: <http://cat.hansa-flex.com/en/HKCDB>

HK W / HK X

Hand pump 700 bar



For cylinders with large oil volumes, the use of 2-stage pumps is recommended

Hand lever can be used as carrying handle after locking.

Design: internal pressure control valve

Operating pressure: max. 700 bar

Connections: 3/8" Female NPT

Note: "W" hand pumps for actuation of single-acting cylinders, one port
 "X" hand pumps with control valve for actuation of double-acting cylinders, two ports

Attention: Please observe separate safety precautions for working with 700 bar equipment (see technical information)!

Identification	useful oil volume	Levels	Volume level 1	Volume level 2	Pressure level 1	Pressure level 2	A	B	C	D	E	Weight
			max. cc	max. cc	max. bar	max. bar						
HK W 10707	660,0	1	2,6		700		500	100	150	40	560	5,0
HK W 20707	660,0	2	8,1	2,0	20	700	500	100	150	40	560	5,0
HK W 11207	1200,0	1	2,6		700		545	100	175	40	560	6,0
HK W 21207	1200,0	2	8,1	2,0	20	700	545	100	175	40	560	6,0
HK W 22307	2200,0	2	13,2	2,2	20	700	560	106	210	55	560	11,0
HK X 02307	2200,0	2	13,2	2,2	20	700	625	106	210	55	560	14,0

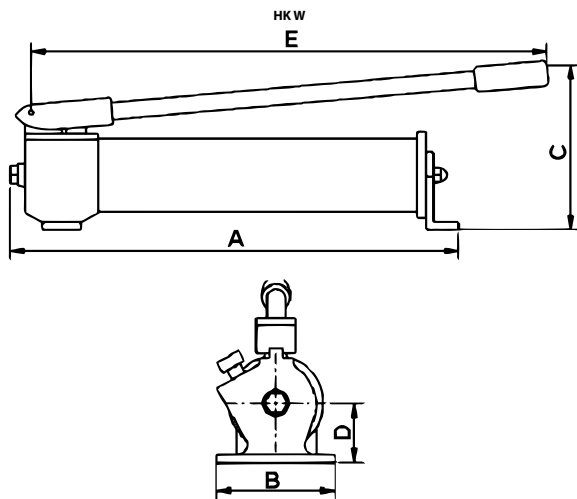

Web: <http://cat.hansa-flex.com/en/HKWHKX>

HK Z PNEU

Pneumo-hydraulic pump 700 bar

Pneumo-hydraulic pumps develop an oil pressure of 700 bar with an air pressure of only 7 bar
 Pump maintains the pressure in rest position
 Actuation of the pedal by hand or foot

Design: double-acting with control valve, internal pressure control valve
Operating pressure: max. 700 bar
Connections: air connection 1/4" NPT Female
Material: Housing: Plastic
Use: for operating double-acting 700 bar cylinder



Note: Attention: Please observe separate safety precautions for working with 700 bar equipment (see technical information)!

Identification	useful oil volume cc	Type	Pressure max. bar	Weight kg
HK Z 12107	2100,0	single-acting	700	7,5
HK Z 22107	2100,0	double-acting	700	7,0

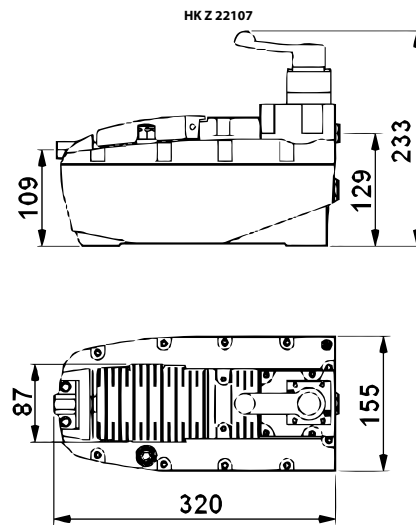
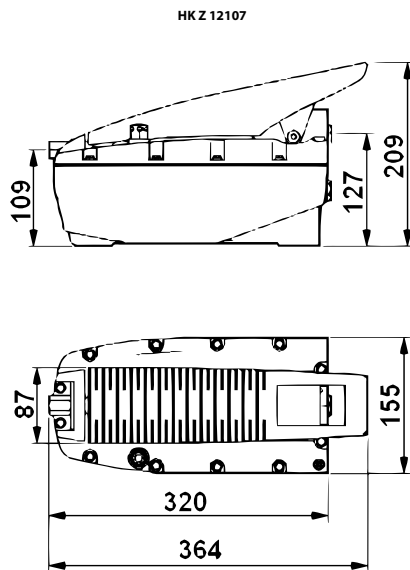

Web: <http://cat.hansa-flex.com/en/HKZPNEU>

HK HAM / HAE

Electro-hydraulic pumps 700 bar

electro-hydraulic pumps (compact power packs) to supply medium and heavy-duty cylinders
 Tank size: 2.5 - 100 litre (tanks steel or aluminium)
 Electric motors for 115 V, 230 V, 400 V
 Optional accessories: Protective brackets, transport rollers, oil coolers

Design: Configuration and delivery on request., with manual or electric magnet-valves
Operating pressure: max. 700 bar
Volumetric flow: 0,36 - 4,00 l/min



Note: Attention: Please observe separate safety precautions for working with 700 bar equipment (see technical information)!

Ordering information: No stock goods, configuration (in fixed graduations) and delivery period upon request!

Identification	Design
Elektrohydraulische Pumpe HAM	Manually switched directional control valve
Elektrohydraulische Pumpe HAE	Electrically switched directional control valve

Web: <http://cat.hansa-flex.com/en/HKHAMHAE>

HK SMX

Flat cylinders 700 bar single-acting with spring retraction



Flat cylinders combine compact design with maximum stroke. Ideal where space is at a premium. Care must be taken that no lateral forces are transmitted to the guide rings.

Flat, compact design

Mounting bores for stationary applications

Design: Hardened valvehead, hard chrome-plated pistons, max. stroke 16 mm, spring return

Operating pressure: max. 700 bar

Scope of supply: with female quick coupling 3/8"-18 NPT

Note: Attention: Please observe separate safety precautions for working with 700 bar equipment (see technical information)!

Identification	Capacity kN	Capacity t	Stroke mm	Area cm ²	A mm	B mm	D mm	F mm	R	S mm	Volume cc	Weight kg
HK SMX 00406	43,8	4	6	6,4	32,5	38,5	41	25	5,5	28	4	0,85
HK SMX 00416	43,8	4	16	6,4	42,5	58,5	41	25	5,5	28	11	1,20
HK SMX 01011	99,7	10	11	14,5	43,0	54,0	56	38	6,5	37	16	1,60
HK SMX 02211	227,8	22	11	33,2	52,0	63,0	80	57	9,0	50	37	2,80
HK SMX 03013	287,3	30	13	41,8	59,0	72,0	95	60	11,0	52	55	4,10
HK SMX 05016	486,5	50	16	70,9	68,0	84,0	114	78	13,0	67	114	6,60
HK SMX 07516	712,9	75	16	103,8	79,0	95,0	140	95	13,0	75	167	12,50
HK SMX 10016	953,6	100	16	138,9	87,0	103,0	158	108	13,0	76	223	15,00
HK SMX 15016	1450,0	150	16	211,2	100,0	116,0	194	134	13,0	117	338	25,00

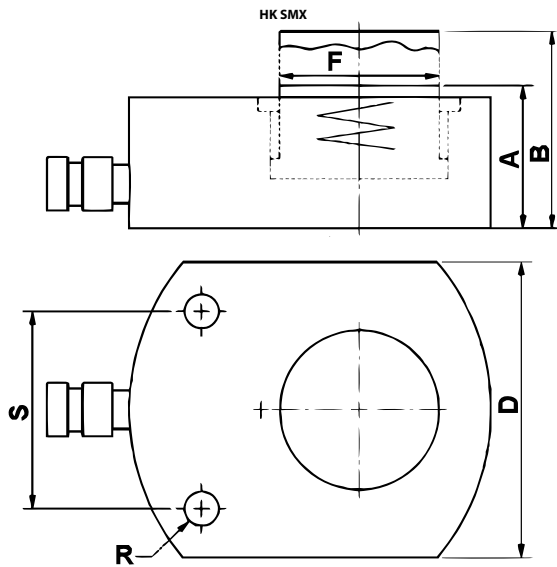

Web: <http://cat.hansa-flex.com/en/HKSMX>

Flat cylinders 700 bar single-acting with spring retraction

Flat cylinders combine compact design with maximum stroke. Ideal where space is at a premium.

Care must be taken that no lateral forces are transmitted to the guide rings.

Flat, compact design

Mounting bores for stationary applications

Design: Hardened valvehead, hard chrome-plated pistons, max. stroke 150 mm, spring return

Operating pressure: max. 700 bar

Scope of supply: with female quick coupling 3/8"-18 NPT



Note: Attention: Please observe separate safety precautions for working with 700 bar equipment (see technical information)!

Ordering information: Moving thrust pieces are available on request for the HK SMP models from 30 to 100 t.

Identification	Capacity kN	Capacity t	Stroke mm	Area cm ²	H mm	A mm	B mm	D mm	F mm	K mm	L mm	N mm	Volume cc	Weight kg
HK SMP 01004	109,0	10	40	15,9	14	89	129	66	36	2			64	2,3
HK SMP 02004	214,0	20	40	31,2	14	101	141	90	56	2			125	4,7
HK SMP 03006	303,0	30	40	44,2	14	121	161	102	60	2	45,5	9,0	177	8,0
HK SMP 05006	486,0	50	60	70,8	16	125	185	127	80	2	61,5	11,5	425	11,0
HK SMP 10006	911,0	100	60	132,7	26	141	201	175	110	2	88,0	12,0	796	23,9
HK SMP 10015	911,0	100	150	132,7	26	254	404	175	110	5	88,0	11,0	1990	40,2

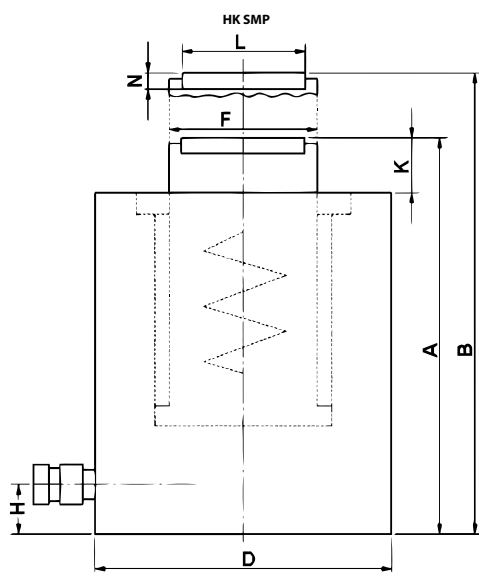

Web: <http://cat.hansa-flex.com/en/HKSMP>

HK STX

Flat cylinders 700 bar single-acting with lock nut



Flat cylinders combine compact design with maximum stroke. Ideal where space is at a premium. Care must be taken that no lateral forces are transmitted to the guide rings.

Flat, compact design

Plunger wiper seals to prevent soiling

All cylinders have a moving thrust piece and special coating for enhanced corrosion protection.

Design: Hardened valvehead, hard chrome-plated pistons, max. stroke 50 mm, retraction on load, with lock nut for positive and safe load holding

Operating pressure: max. 700 bar

Scope of supply: with female quick coupling 3/8"-18 NPT

Note: Attention: Please observe separate safety precautions for working with 700 bar equipment (see technical information)!

Identification	Capacity kN	Capacity t	Stroke mm	Area cm ²	A mm	B mm	D mm	F	J mm	L mm	Volume cc	Weight kg
HK STX 05005	486,0	50	50	70,8	125	175	120	Tr 95 x 4	21,0	92,0	355	11
HK STX 14004	1380,0	140	45	200,9	148	193	205	Tr 160 x 6	38,0	147,5	905	39

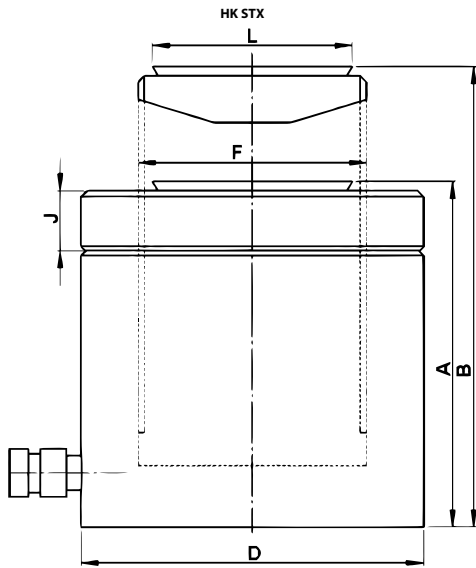

Web: <http://cat.hansa-flex.com/en/HKSTX>

Hollow piston cylinder 700 bar

Hollow piston cylinders are employed for pushing and pulling actuation.
 Thread on cylinder housing ensures simple mounting
 Plunger wiper seals to prevent soiling
 Replaceable supporting head

Design: Hardened valvehead, hard chrome-plated pistons, max. stroke 76 mm, retraction on load

Operating pressure: max. 700 bar

Scope of supply: with female quick coupling 3/8"-18 NPT



Note: Attention: Please observe separate safety precautions for working with 700 bar equipment (see technical information)!

Identification	Capacity kN	Capacity t	Stroke mm	Area cm ²	H mm	A mm	B mm	C mm	D mm	E mm	F mm	I	J mm	K mm	L mm	M	N mm	R
HK SH 01208	121,0	12	76	17,6	19	176	252	20,5	75	55	40	2.3/4" - 16	30	2,5	55	M28 x 1.5	18	5/16" - 18
HK SH 03006	301,8	30	64	44,0	26	197	261	33,4	120	90	68	4.1/2" - 12	42	4,0	55	1.13/16" - 16	22	3/8" - 16
HK SH 06008	578,2	60	76	84,2	31	253	329	54,0	165	125	95	6.1/4" - 12	48	4,0	80	2.3/4" - 16	22	1/2" - 13

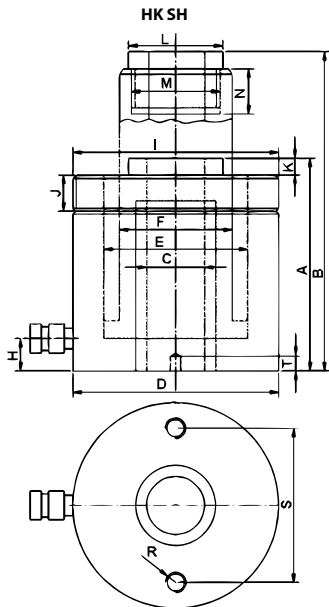

Web: <http://cat.hansa-flex.com/en/HKSH>

HK SM

Universal cylinders 700 bar single-acting with spring retraction



Universal cylinder for a wide range of applications.

Care must be taken that no lateral forces are transmitted to the guide rings.

Compact design

Plunger wiper seals to prevent soiling

Mounting bores for stationary applications

Design: Hardened valvehead, hard chrome-plated pistons, max. stroke 257 mm, spring return

Operating pressure: max. 700 bar

Scope of supply: with female quick coupling 3/8"-18 NPT

Note: Attention: Please observe separate safety precautions for working with 700 bar equipment (see technical information)!

Identification	Capacity kN	Capacity t	Stroke mm	Area cm ²	A mm	B mm	D mm	F mm	I	K mm	R	S mm	Volume cc	Weight kg
HK SM 00513	48,5	5	127	7,1	219	346	40	25	1.1/2" -16	6	1/4" -20	25	90	1,9
HK SM 01010	109,2	10	105	15,9	172	277	60	36	2.1/4" -14	6	5/16" -18	39	167	3,0
HK SM 01015	109,2	10	155	15,9	247	402	60	36	2.1/4" -14	6	5/16" -18	39	247	4,3
HK SM 01025	109,2	10	257	15,9	352	609	60	36	2.1/4" -14	6	5/16" -18	39	409	6,0
HK SM 01510	163,0	15	105	23,8	205	310	75	45	2.3/4" -16	8	3/8" -16	47	250	5,8
HK SM 01515	163,0	15	155	23,8	275	430	75	45	2.3/4" -16	8	3/8" -16	47	369	7,5
HK SM 01525	163,0	15	257	23,8	379	636	75	45	2.3/4" -16	8	3/8" -16	47	611	9,8
HK SM 02305	227,8	23	51	33,2	166	217	85	56	3.5/16" -12	10	1/2" -13	58	170	6,2
HK SM 02310	227,8	23	102	33,2	217	319	85	56	3.5/16" -12	10	1/2" -13	58	339	7,8
HK SM 02321	227,8	23	210	33,2	327	537	85	56	3.5/16" -12	10	1/2" -13	58	697	11,4
HK SM 03015	303,2	30	150	44,2	270	420	100	60	3.7/8" -12	10	1/2" -13	74	663	13,1

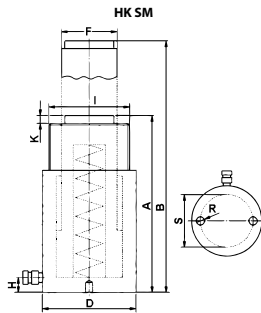

Web: <http://cat.hansa-flex.com/en/HKSM>

HK TE
Traction cylinders 700 bar

For applications in which tensile forces are required.
 Optional protective metal bellows (stroke 30 mm shorter)
 Plunger wiper seals to prevent soiling

Design: hard chrome-plated pistons, max. stroke 150 mm

Operating pressure: max. 700 bar

Scope of supply: with female quick coupling 3/8"-18 NPT



Note: Attention: Please observe separate safety precautions for working with 700 bar equipment (see technical information)!

Identification	Capacity kN	Capacity t	Stroke mm	Area cm ²	A mm	B mm	D mm	E mm	F mm	M	Volume cc	Weight kg
HK TE 01015	93,2	10	150	13,5	576	726	86	55	36	M30 x 2	204	14,9
HK TE 03015	301,8	30	150	43,9	723	873	125	90	50	M40 x 2	660	32,0

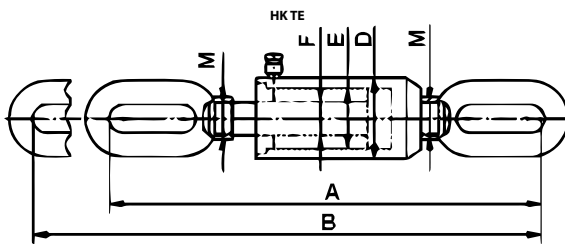

Web: <http://cat.hansa-flex.com/en/HKTE>

HK ECM
Workbench press 700 bar

high-strength welded frame
 Includes a pressure gauge to be installed by the user
 Equipped with V-blocks for easier positioning of pipe and bar material in the press
 Max. height under press cylinder: 352 mm

Operating pressure: max. 700 bar

Scope of supply: Supplied with hand pump, 1500 mm hose and quick release couplings

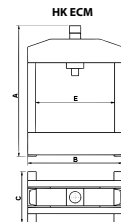

Note: Attention: Please observe separate safety precautions for working with 700 bar equipment (see technical information)!

Identification	Capacity kN	Capacity t	Stroke mm	A mm	B mm	C mm	D mm	E mm	for pump	Weight kg
HK ECM 01113	93,2	10	130	720	440	220	80	350	HK W 00607	41

Web: <http://cat.hansa-flex.com/en/HKECM>

HK HV RK

2-way ball valve, 700 bar, in block design

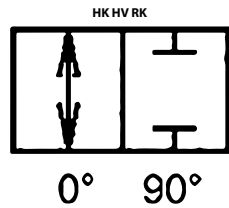

Operating pressure: max. 700 bar
Volumetric flow: max. 27 l/min
Connection 1 + 2: NPT internal thread
Material: Steel housing, ball and operating shaft

Identification	Thread	Width mm	Length mm	AF mm	Weight kg
HK HV1 RK	1/4" NPT	35	70	27	0,55
HK HV2 RK	3/8" NPT	35	70	27	0,55
Qmax - max intake volumetric flow AF = Width across flats					

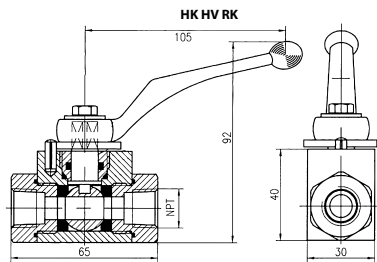

Web: <http://cat.hansa-flex.com/en/HKHVRK>

HK AZ51

Needle shut-off valve 700 bar

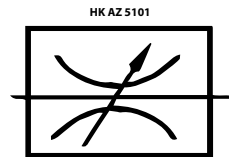

Operating pressure: max. 700 bar
Volumetric flow: max. 25 l/min

Note: Supplied without threaded connections

Identification	Function	Thread	Weight kg
HK AZ 5101	1 inlet / 1 outlet	3/8" NPT	0,77
HK AZ 5102	1 inlet / 2 outlets	3/8" NPT	3,10

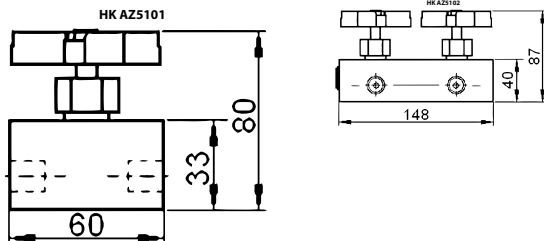

Web: <http://cat.hansa-flex.com/en/HKAZ51>

HK AZ52 DRV

Regulating check valve 700 bar

Operating pressure: max. 700 bar
Volumetric flow: max. 25 l/min

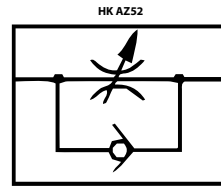

Note: Supplied without threaded connections

Identification	Thread	Weight kg
HK AZ 5255	3/8" NPT	0,94

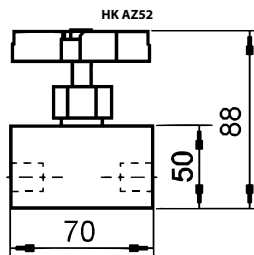

Web: <http://cat.hansa-flex.com/en/HKAZ52DRV>

HK AZ55 RV

Non-return valve 700 bar

Operating pressure: max. 700 bar
Volumetric flow: max. 25 l/min

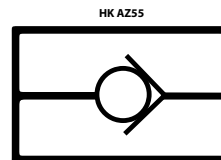

Identification	Thread	L mm	AF mm	Weight kg
HK AZ 5500	3/8" NPT	101	35	0,7

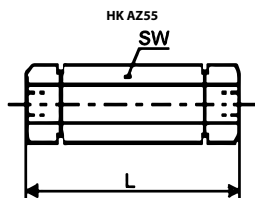

Web: <http://cat.hansa-flex.com/en/HKAZ55RV>

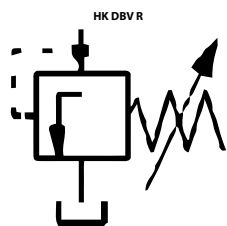
HK DBV R**Pressure relief valve 700 bar**

Operating pressure: max. 700 bar
 Volumetric flow: max. 40 l/min

Note: These valves must be set according to the application.

Identification	Thread	Q max. L/min	Weight kg
HK DBV 4 R	G 3/8"	12	0,3
HK DBV 5 R	G 1/2"	20	0,4
HK DBV 6 R	G 3/4"	40	0,7

Web: <http://cat.hansa-flex.com/en/HKDBVR>

HK MD
Glycerine pressure gauge up to 1000 bar

Operating pressure: max. 1000 bar
Connection: at bottom
Design: Pipe spring pressure gauge with glycerine filling
Damping: due to glycerine filling



Note: Application range at idle load: 3/4 x full scale.
 Application range with alternating load: 2/3 x full scale.

Ordering information: Other pressure gauges on request.

Identification	Diameter mm	Thread	Weight kg
HK MD 7100	100	1/2" NPT	0,46
HK MD 7063	63	1/4" NPT	0,18

Web: <http://cat.hansa-flex.com/en/HKMD>

Accessories:

HK MA - Pressure gauge adapter 700 bar

HK MA
Pressure gauge adapter 700 bar

For installing pressure gauges with NPT connector

Operating pressure: max. 700 bar



Identification	A mm	B mm	C mm	dia. D	Ø E	dia. F	Weight kg
HK MA 1	71	32	32	3/8" NPT	3/8" NPT	1/2" NPT	0,9
HK MA 3	117	40	32	3/8" NPT	3/8" NPT	1/4" NPT	0,9
HK MA 4	155	35	32	3/8" NPT	3/8" NPT	1/2" NPT	0,9
HK MA 5	71	31	32	3/8" NPT	3/8" NPT	1/4" NPT	0,9

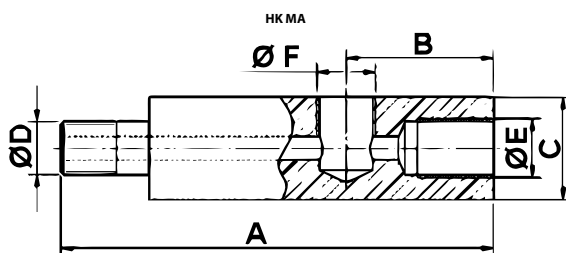

Web: <http://cat.hansa-flex.com/en/HKMA>

HK AZ16**Manifolds 700 bar**

Operating pressure: max. 700 bar

1

Note: Inlet B: Pressure gauge fitting with blank plug

Identification	Connections	A	B	C mm	Angle D °	Weight kg
HK AZ 1604	1 inlet / 4 outlets	NPT 3/8" -18	BSP 3/8" -19	82,0	60	1,9
HK AZ 1606	1 inlet / 6 outlets	NPT 3/8" -18	BSP 3/8" -19	102,0	48	2,9

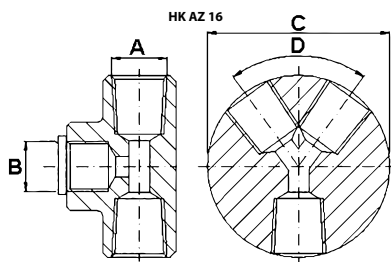

Web: <http://cat.hansa-flex.com/en/HKAZ16>

HK HV 700

Adapter and threaded connectors 700 bar

Operating pressure: max. 700 bar
Surface: phosphate treated
Material: Steel C45



Ordering information: Other screw fittings on request.

Identification	Design	A	B	D	C	E	Weight
				mm		mm	kg
HK HV NAA 14 14	Male thread/Male thread connector	NPT 1/4"	NPT 1/4" -18	38			0,05
HK HV NAA 38 38	Male thread/Male thread connector	NPT 3/8" -18	NPT 3/8" -18	51			0,05
HK HV ZII 14 14	Female thread/female thread connector	NPT 1/4"	NPT 1/4" -18	29			0,08
HK HV ZII 38 38	Female thread/female thread connector	NPT 3/8" -18	NPT 3/8" -18	36			0,08
HK HV RAI 38 14	Male thread/female thread reduction	NPT 1/4"	NPT 3/8" -18	19			0,15
HK HV RII 38 14	Female thread/female thread reduction	NPT 1/4"	NPT 3/8" -18	28			0,14
HK HV WAI 38 38	Male thread/female thread elbow	NPT 3/8" -18	NPT 3/8" -18	45		35	0,16
HK HV WII 38 38	Female thread/female thread elbow	NPT 3/8" -18	NPT 3/8" -18	33		33	0,16
HK HV TIII 14 14 14	Female thread/female thread/female thread T-piece	NPT 1/4"	NPT 1/4" -18	45	NPT 1/4" -18	33	0,20
HK HV TIII 38 38 38	Female thread/female thread/female thread T-piece	NPT 3/8" -18	NPT 3/8" -18	45	NPT 3/8" -18	33	0,20

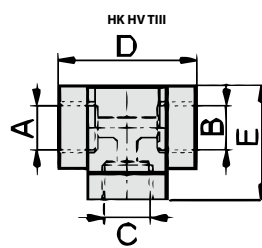
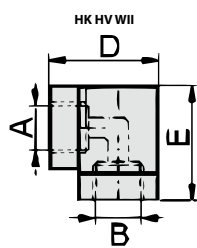
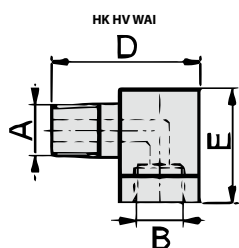
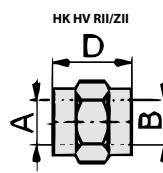
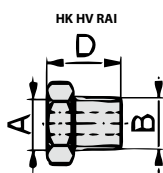
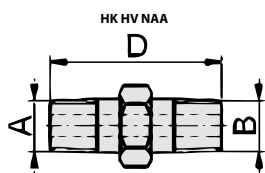

Web: <http://cat.hansa-flex.com/en/HKHV700>

HK AZ11

Blind plugs

Operating pressure: max. 700 bar
Connection 1: NPT external threads
Design: Blanking socket, with hexagon head
Construction: straight
Sealing form 1: thread seal
Surface: galvanised

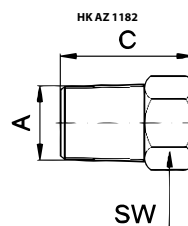

Identification	A	C	AF	Weight
		mm	mm	kg
HK AZ 1182	NPT 3/8" -18	24	18	0,7

AF = Width across flats

Web: <http://cat.hansa-flex.com/en/HKAZ11>

HK KPL 700BAR**Couplings, dust protection 700 bar**

Screw couplings are designed for high pressures and pressure pulses.
Coupling under residual pressure is possible.

Operating pressure: max. 700 bar

Connection 1: NPT external threads, NPT internal thread

Sealing form 1: thread seal

Material: Steel, Aluminium

Identification	Thread	Type
SKL 10 HN SP	3/8" NPT - AG	Coupling half - sleeve
SKF 10 IN SP	3/8" NPT - IG	Coupling half - connector
SKL ZUBS SP 06	-	Dust protection for sleeve
SKF ZUBS SP 06	-	Dust protection for connector

Web: <http://cat.hansa-flex.com/en/HKKPL700BAR>

Additional info: The robust construction makes them ideal for use in harsh conditions.



Filtration

Filter	
Suction filter	408
Return flow filters	409
Spin-on filters	415
Pressure filters	420
Adsorber filters	429
Accessories	437
Oil sample	
Fluid sampling sets	439
Individual parts	440
Oil analysis	
Oil analysis equipment	443
Accessories	447
Filtration	
Partial flow filter systems	448
Oil service appliance	450
Oils and bonding agents	
Hydraulic fluids	452
Oil binding agents	454

FI SG E MP

Filter element for suction filter MP

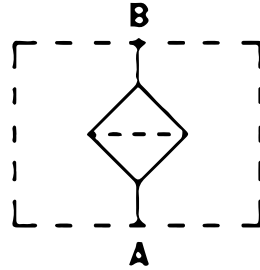

These filters protect hydraulic pumps from coarse dirt from the tank. They are flush-mounted the tank.

- Design:** without bypass valve
- Temp. min.:** -25 °C
- Temp. max.:** 110 °C
- Material:** Gasket: NBR
- Operating pressure:** max. 12 bar
- Filter material:** Wire mesh

Ordering information: Available on request: Other filter mesh sizes, other threads, filter with bypass or magnet

Identification	Filter mesh size		Filter area cm ²	Qmax L/min	G1	L mm	Ø B mm	AF mm	Weight kg
	µm								
FI SG E MP 0078 M90	90		290	20	G 3/8"	79,0	52,0	30	0,16
FI SG E MP 0078 M90 1/2	90		290	28	G 1/2"	79,0	52,0	30	0,16
FI SG E MP 0095 M90 1/2	90		470	28	G 1/2"	95,0	70,0	41	0,16
FI SG E MP 0095 M90 3/4	90		470	66	G 3/4"	95,0	70,0	41	0,22
FI SG E MP 0135 M90 11/4	90		1046	170	G 1.1/4"	137,0	99,0	69	0,47
FI SG E MP 0135 M90 11/2	90		1046	170	G 1.1/2"	137,0	99,0	69	0,47
FI SG E MP 0140 M90 3/4	90		720	66	G 3/4"	141,0	70,0	41	0,30
FI SG E MP 0140 M90 1	90		720	130	G 1"	141,0	70,0	41	0,30
FI SG E MP 0140 M250 1	250		720	900	G 1"	141,0	70,0	41	0,30
FI SG E MP 0140 M90 11/2	90		2000	250	G 1.1/2"	160,0	130,0	70	0,84
FI SG E MP 0140 M90 2	90		2000	470	G 2"	160,0	130,0	70	0,84
FI SG E MP 0225 M90 11/4	90		1850	170	G 1.1/4"	227,0	99,0	69	0,68
FI SG E MP 0225 M90 11/2	90		1850	250	G 1.1/2"	227,0	99,0	69	0,68
FI SG E MP 0225 M90 2	90		1850	470	G 2"	227,0	99,0	69	0,68
FI SG E MP 0262 M90 2	90		3550	470	G 2"	262,0	130,0	69	1,25
FI SG E MP 0270 M90 21/2	90		3550	840	G 2.1/2" -11	272,0	130,0	101	1,25
FI SG E MP 0270 M90 3	90		3620	980	G 3" -11	272,0	130,0	101	1,25
FI SG E MP 0330 M90 3	90		4160	980	G 3" -11	330,0	130,0	101	1,30

Qmax - max intake volumetric flow

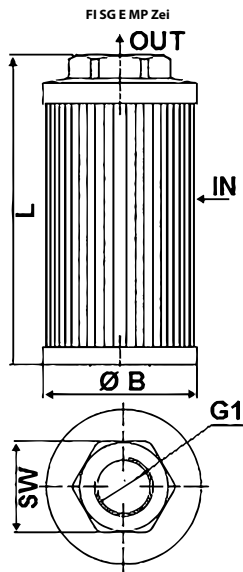

Web: <http://cat.hansa-flex.com/en/FISGEMP>

Return flow filters

Return flow filter for fitting into the tank cap; dimensions for drilling pattern see graphic.
 Pressure differential for filter element paper (P) max. 3 bar
 Pressure differential for inorganic filter element (A) max. 10 bar
 Connector for clogging indicator G 1/8" closed with bolt
 Design (Qmax.) for medium ISO VG 46
 at 50°C (30 mm2/s) at $\Delta p_{tot} = 0.4$ bar

Design: with bypass valve 1.75 bar, without clogging indicator
Temp. min.: -25 °C
Temp. max.: 110 °C
Material: Gasket: NBR
Operating pressure: max. 8 bar
Scope of supply: incl. filter element

Note: Dimension "L": clearance required for changing the filter element



Identification	Line connection	Ø A	Ø B	Ø C	Ø D	Ø d	Q max.	L	L1	L2	L3	L4	L5	L6	Type	Weight kg
		mm	mm	mm	mm	mm	L/min	mm	mm	mm	mm	mm	mm	mm		
FI RL 024 A10 N V G1/2	G 1/2"	66,0	60,0	32,0	90,0	67,0	24	100,0	86,0	59,0	22,0	19,0	8,0	90,0	A	0,36
FI RL 048 P10 N V G1/2	G 1/2"	66,0	60,0	32,0	90,0	67,0	60	100,0	86,0	59,0	22,0	19,0	8,0	90,0	A	0,40
FI RL 053 A10 N V G1/2	G 1/2"	88,0	80,0	38,0	115,0	89,0	53	120,0	100,0	82,0	32,0	24,0	12,0	115,0	A	0,74
FI RL 110 P10 N V G1/2	G 1/2"	88,0	80,0	38,0	115,0	89,0	86	120,0	100,0	82,0	32,0	24,0	12,0	115,0	A	0,61
FI RL 053 A10 N V G3/4	G 3/4"	88,0	80,0	38,0	115,0	89,0	53	120,0	100,0	82,0	32,0	24,0	12,0	115,0	A	0,74
FI RL 086 P10 N V G3/4	G 3/4"	88,0	80,0	38,0	115,0	89,0	86	120,0	100,0	82,0	32,0	24,0	12,0	115,0	A	0,74
FI RL 053 A10 N V G1	G 1"	88,0	80,0	38,0	115,0	89,0	53	120,0	100,0	82,0	32,0	24,0	12,0	115,0	A	0,76
FI RL 086 P10 N V G1	G 1"	88,0	80,0	38,0	115,0	89,0	86	120,0	100,0	82,0	32,0	24,0	12,0	115,0	A	0,76
FI RL 064 A10 N V G3/4	G 3/4"	88,0	80,0	38,0	115,0	89,0	64	170,0	150,0	80,0	32,0	24,0	12,0	115,0	A	0,76
FI RL 150 P10 N V G3/4	G 3/4"	88,0	80,0	38,0	115,0	89,0	110	170,0	150,0	80,0	32,0	24,0	12,0	115,0	A	0,61
FI RL 064 A10 N V G1	G 1"	88,0	80,0	38,0	115,0	89,0	64	170,0	150,0	80,0	32,0	24,0	12,0	115,0	A	0,76
FI RL 150 P10 N V G1	G 1"	88,0	80,0	38,0	115,0	89,0	110	170,0	150,0	80,0	32,0	24,0	12,0	115,0	A	0,61
FI RL 125 A10 N V G3/4	G 3/4"	88,0	80,0	46,5	115,0	89,0	125	250,0	225,0	80,0	32,0	24,0	12,0	115,0	A	0,88
FI RL 225 P10 N V G3/4	G 3/4"	88,0	80,0	46,5	115,0	89,0	220	250,0	225,0	80,0	32,0	24,0	12,0	115,0	A	0,67
FI RL 125 A10 N V G1	G 1"	88,0	80,0	46,5	115,0	89,0	125	250,0	225,0	80,0	32,0	24,0	12,0	115,0	A	0,88
FI RL 225 P10 N V G1	G 1"	88,0	80,0	46,5	115,0	89,0	220	250,0	225,0	80,0	32,0	24,0	12,0	115,0	A	0,67
FI RL 230 A10 N V G11/4	G 1.1/4"	129,5	112,0	47,0	175,0	131,0	230	250,0	233,0	91,0	35,0	31,0	13,0	175,0	C	1,86
FI RL 190 P10 N V G11/4	G 1.1/4"	129,5	112,0	47,0	175,0	131,0	280	250,0	233,0	91,0	35,0	31,0	13,0	175,0	C	2,20
FI RL 290 A10 N V G11/4	G 1.1/4"	173,5	150,0	51,0	220,0	174,5	290	200,0	180,0	97,0	38,5	38,0	12,5	220,0	B	3,42
FI RL 280 P10 N V G11/4	G 1.1/4"	173,5	150,0	51,0	220,0	174,5	370	200,0	180,0	97,0	38,5	38,0	12,5	220,0	B	3,00
FI RL 290 A10 N V G11/2	G 1.1/2"	173,5	150,0	51,0	220,0	174,5	290	200,0	180,0	97,0	38,5	38,0	12,5	220,0	B	3,42
FI RL 370 P10 N V G11/2	G 1.1/2"	173,5	150,0	51,0	220,0	174,5	370	200,0	180,0	97,0	38,5	38,0	12,5	220,0	B	3,42
FI RL 290 A10 N V G2	G 2"	173,5	150,0	51,0	220,0	174,5	290	200,0	180,0	97,0	38,5	38,0	12,5	220,0	B	3,42
FI RL 370 P10 N V G2	G 2"	173,5	150,0	51,0	220,0	174,5	370	200,0	180,0	97,0	38,5	38,0	12,5	220,0	B	3,42

A10 with inorganic filter (10 µm), absolute filtration P10 paper filter (10 µm), nominal filtration Qmax - max intake volumetric flow →

Return flow filters

Identification	Line connection	Ø A	Ø B	Ø C	Ø D	Ø d	Q max.	L	L1	L2	L3	L4	L5	L6	Type	Weight
		mm	mm	mm	mm	mm	L/min	mm	mm	mm	mm	mm	mm	mm		kg
FI RL 450 A10 N V G11/2	G 1.1/2"	173,5	150,0	64,0	220,0	174,5	450	250,0	238,0	98,5	38,5	38,0	12,5	220,0	B	3,42
FI RL 320 P10 N V G11/2	G 1.1/2"	173,5	150,0	64,0	220,0	174,5	610	250,0	238,0	98,5	38,5	38,0	12,5	220,0	B	3,50
FI RL 540 A10 N V G11/2	G 1.1/2"	173,5	150,0	64,0	220,0	174,5	540	310,0	290,0	97,0	38,5	38,0	12,5	220,0	B	3,70
FI RL 420 P10 N V G11/2	G 1.1/2"	173,5	150,0	64,0	220,0	174,5	675	310,0	290,0	97,0	38,5	38,0	12,5	220,0	B	3,70
FI RL 540 A10 N V G2	G 2"	173,5	150,0	64,0	220,0	174,5	540	310,0	290,0	97,0	38,5	38,0	12,5	220,0	B	3,70
FI RL 675 P10 N V G2	G 2"	173,5	150,0	64,0	220,0	174,5	675	310,0	290,0	97,0	38,5	38,0	12,5	220,0	B	3,70
FI RL 620 A10 N V SAE2	2" SAE 3000 PSI/M	173,5	150,0	64,0	220,0	174,5	620	450,0	430,0	105,0	48,5	38,0	12,5	220,0	B	5,68
FI RL 750 P10 N V SAE2	2" SAE 3000 PSI/M	173,5	150,0	64,0	220,0	174,5	750	450,0	430,0	105,0	48,5	38,0	12,5	220,0	B	5,68
FI RL 620 A10 N V G2	G 2"	173,5	150,0	64,0	220,0	174,5	620	450,0	430,0	105,0	48,5	38,0	12,5	220,0	B	5,68
FI RL 750 P10 N V G2	G 2"	173,5	150,0	64,0	220,0	174,5	750	450,0	430,0	105,0	48,5	38,0	12,5	220,0	B	5,68

A10 with inorganic filter (10 µm), absolute filtration P10 paper filter (10 µm), nominal filtration Qmax - max intake volumetric flow

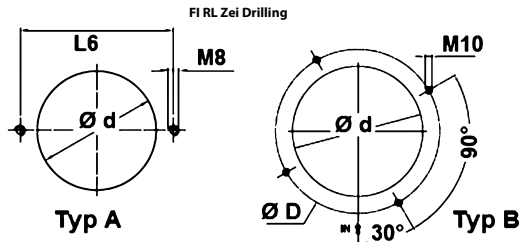
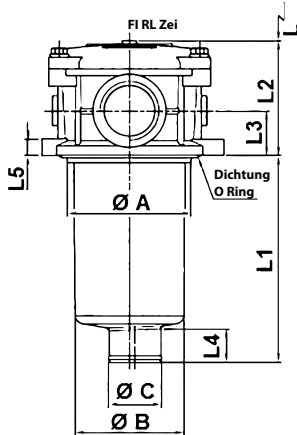

Option for assembly with two drill holes on the tank

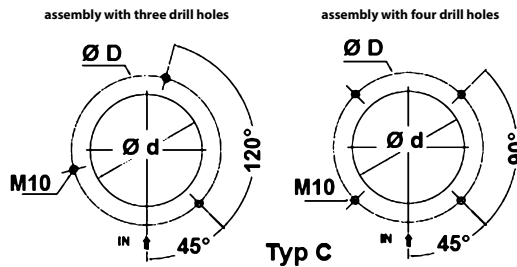

Web: <http://cat.hansa-flex.com/en/FIRL>

Spare parts:

- FI RL E MP - Filter element for return filter MP
- FI RL GEH - Housing for return flow filter

Accessories:

- HK VA MAN - Clogging indicator pressure gauge
- FI RL RVL - Tube extension for return flow filter

FI RL GEH
Housing for return flow filter

Return flow filter for fitting into the tank cap; dimensions for drilling pattern see graphic.
Connector for clogging indicator G 1/8" closed with bolt

Design: with bypass valve 1.75 bar, without clogging indicator
Material: Gasket: NBR
Operating pressure: max. 8 bar
Scope of supply: without filter element



Note: Dimension "L": clearance required for changing the filter element

Ordering information: Filter element is not included. Please order separately.

Identification	for filter type	Line connection	Ø A	Ø B	Ø C	Ø d	L	L1	L2	L3	L4	L5	L6	Type	Weight
			mm	mm	mm	mm	mm	mm	mm	mm	mm	mm	mm		kg
FI RL GEH N 024 048 1/2	FI RL 024, 048	G 1/2"	66,0	60,0	32,0	67,0	100,0	86,0	59,0	22,0	19,0	8,0	90,0	A	0,28
FI RL GEH N 053 110 1/2	FI RL 053, 110	G 1/2"	88,0	80,0	38,0	89,0	120,0	100,0	82,0	32,0	24,0	12,0	115,0	A	0,58
FI RL GEH N 053 086 3/4	FI RL 053, 086	G 3/4"	88,0	80,0	38,0	89,0	120,0	100,0	82,0	32,0	24,0	12,0	115,0	A	0,58
FI RL GEH N 053 086 1	FI RL 053, 086	G 1"	88,0	80,0	38,0	89,0	120,0	100,0	82,0	32,0	24,0	12,0	115,0	A	0,58
FI RL GEH N 064 150 3/4	FI RL 064, 150	G 3/4"	88,0	80,0	38,0	89,0	170,0	150,0	80,0	32,0	24,0	12,0	115,0	A	0,60
FI RL GEH N 064 150 1	FI RL 064, 150	G 1"	88,0	80,0	38,0	89,0	170,0	150,0	80,0	32,0	24,0	12,0	115,0	A	0,60
FI RL GEH N 125 225 3/4	FI RL 125, 225	G 3/4"	88,0	80,0	46,5	89,0	250,0	225,0	80,0	32,0	24,0	12,0	115,0	A	0,64
FI RL GEH N 125 225 1	FI RL 125, 225	G 1"	88,0	80,0	46,5	89,0	250,0	225,0	80,0	32,0	24,0	12,0	115,0	A	0,64
FI RL GEH N 190 230 1 1/4	FI RL 190, 230	G 1.1/4"	129,5	112,0	47,0	131,0	250,0	233,0	91,0	35,0	31,0	13,0	175,0	C	1,41
FI RL GEH N 280 290 1 1/4	FI RL 280, 290	G 1.1/4"	173,5	150,0	51,0	174,5	200,0	180,0	97,0	38,5	38,0	12,5	220,0	B	2,87
FI RL GEH N 290 370 1 1/2	FI RL 290, 370	G 1.1/2"	173,5	150,0	51,0	174,5	200,0	180,0	97,0	38,5	38,0	12,5	220,0	B	2,87
FI RL GEH N 290 370 2	FI RL 290, 370	G 2"	173,5	150,0	51,0	174,5	200,0	180,0	97,0	38,5	38,0	12,5	220,0	B	2,87
FI RL GEH N 320 450 1 1/2	FI RL 320, 450	G 1.1/2"	173,5	150,0	64,0	174,5	250,0	238,0	98,5	38,5	38,0	12,5	220,0	B	2,87
FI RL GEH N 420 540 1 1/2	FI RL 420, 540	G 1.1/2"	173,5	150,0	64,0	174,5	310,0	290,0	97,0	38,5	38,0	12,5	220,0	B	2,87
FI RL GEH N 540 675 2	FI RL 540, 675	G 2"	173,5	150,0	64,0	174,5	310,0	290,0	97,0	38,5	38,0	12,5	220,0	B	2,87
FI RL GEH N 620 750 2	FI RL 620, 750	G 2"	173,5	150,0	64,0	174,5	450,0	430,0	105,0	48,5	38,0	12,5	220,0	B	4,36
FI RL GEH N 620 750 SAE2	FI RL 620, 750 SAE	SAE 3000 PSI/M	173,5	150,0	64,0	174,5	450,0	430,0	105,0	48,5	38,0	12,5	220,0	B	4,36

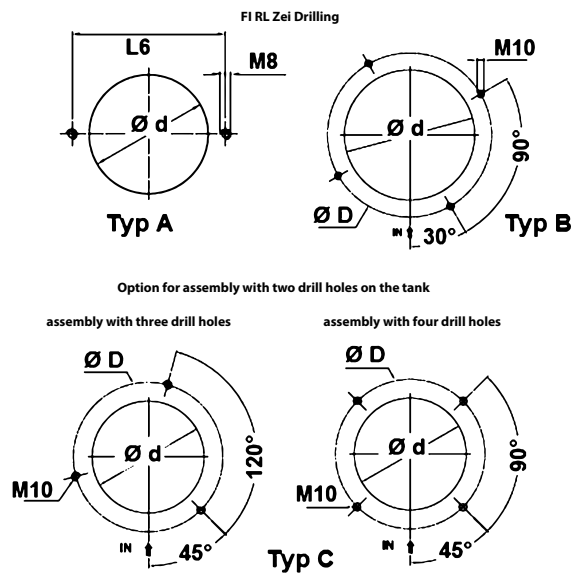
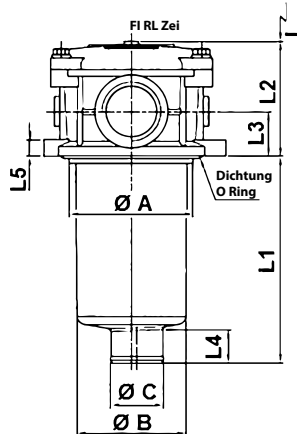

Web: <http://cat.hansa-flex.com/en/FIRLGEH>

Spare part for following products:

FI RL - Return flow filters

Accessories:

HK VA MAN - Clogging indicator pressure gauge

FI RL RVL - Tube extension for return flow filter

Additional elements:

FI RL E MP - Filter element for return filter MP

HK RTR

Return flow filter compact tank installation

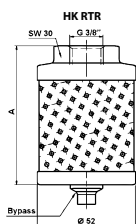

Compact return flow filter for direct installation in the return pipe in the tank below the oil level.

Design (Qmax.) for medium ISO VG 46 at 50°C (30 mm²/s) at Δp_{tot} = 0.4 bar

Design: with bypass valve 1.75 bar

Operating pressure: max. 8 bar

Ordering information: Filter materials for other types of oil, viscosities or temperatures available on request

Identification	Filter area cm ²	Line connection	Q max. L/min	A mm	Weight kg
HK RTR 050 1CG1 P10	300	G 3/8"	10	78	0,2
HK RTR 050 2 CG1 P10	600	G 3/8"	20	121	0,4
P10 paper filter (10 μm), nominal filtration Qmax - max intake volumetric flow					

Web: <http://cat.hansa-flex.com/en/HKRTR>

FI R L E M P

Filter element for return filter MP

Pressure differential for filter element paper (P) max. 3 bar
 Pressure differential for inorganic filter element (A) max. 10 bar

Temp. min.: -25 °C
Temp. max.: 120 °C
Material: Gasket: NBR
Use: For return flow filter FI RL

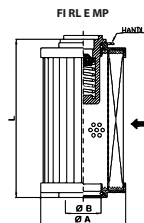

Identification	Filter mesh size	Filter area cm ²	Q _{max} L/min	Filter material	for filter type	Ø A mm	Ø B mm	L mm	bypass valve	Weight kg
	µm									
FI RL E MP 0072 A10	10,0	313	25	inorganic	FI RL 024, 048	52	24,5	72,00	with	0,16
FI RL E MP 0072 P10	10,0	392	25	organic	FI RL 024, 048	52	24,5	72,00	with	0,16
FI RL E MP 0085 A10	10,0	690	100	inorganic	FI RL 053, 086	70	29,5	85,00	with	0,20
FI RL E MP 0085 P10	10,0	828	100	organic	FI RL 053, 086	70	29,5	85,00	with	0,16
FI RL E MP 0130 A10	10,0	1140	100	inorganic	FI RL 064, 150	70	29,5	130,00	with	0,22
FI RL E MP 0130 P10	10,0	1368	100	organic	FI RL 064, 150	70	29,5	130,00	with	0,22
FI RL E MP 0145 P10	10,0	4000	600	organic	FI RL 290, 370	130	51,5	145,00	with	1,00
FI RL E MP 0145 A10	10,0	3600	600	inorganic	FI RL 290, 370	130	51,5	145,00	with	1,00
FI RL E MP 0204 A10	10,0	5299	300	inorganic	FI RL 320, 450	130	64,5	204,00	with	1,00
FI RL E MP 0204 P10	10,0	5888	300	organic	FI RL 320, 450	130	64,5	204,00	with	1,00
FI RL E MP 0211 A10	10,0	1358	150	inorganic	FI RL 125, 225	70	40,5	211,50	with	0,28
FI RL E MP 0211 P10	10,0	1629	150	organic	FI RL 125, 225	70	40,5	211,50	with	0,28
FI RL E MP 0220 A10	10,0	3360	250	inorganic	FI RL 190, 230	99	40,5	220,00	with	0,70
FI RL E MP 0220 P10	10,0	3840	250	organic	FI RL 190, 230	99	40,5	220,00	with	0,70
FI RL E MP 0254 A10	10,0	6739	380	inorganic	FI RL 420, 540, 675	130	64,5	254,00	with	1,19
FI RL E MP 0254 P10	10,0	7488	380	organic	FI RL 420, 540, 675	130	64,5	254,00	with	1,19
FI RL E MP 0404 A10	10,0	11059	600	inorganic	FI RL 620, 750	130	64,5	404,00	with	2,00
FI RL E MP 0404 P10	10,0	12288	600	organic	FI RL 620, 750	130	64,5	404,00	with	2,00
FI RL E MP 0050 A25	25,0	1140	100	inorganic	FI RL 064, 150	70	29,5	130,00	with	0,28
FI RL E MP 0050 P25	25,0	1368	100	organic	FI RL 064, 150	70	29,5	130,00	with	0,16
FI RL E MP 0120 A25	25,0	3259	300	inorganic	-	99	51,5	210,00	without	0,53
FI RL E MP 0200 A25	25,0	11325	600	inorganic	-	130	76,0	500,00	without	0,50

Q_{max} - max intake volumetric flow

Web: <http://cat.hansa-flex.com/en/FIRLEMP>

Spare part for following products:

FI RL - Return flow filters

Additional elements:

FI RL GEH - Housing for return flow filter

FI R L E A R

Filter element for return filter AR

Design: with bypass valve 1.5 bar
Temp. min.: -25 °C
Temp. max.: 120 °C
Material: Gasket: NBR
Operating pressure: Max. 20 bar

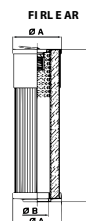

Identification	Filter mesh size	Filter area cm ²	Filter material	Ø A mm	Ø B mm	L mm	Weight kg
	µm						
FI RL E AR 0040 P25 V1.5	25,0	1879	organic	50	19,5	100,00	0,55
FI RL E AR 0050 P16 V1.5	16,0	1879	organic	60	28,5	200,15	0,29

Web: <http://cat.hansa-flex.com/en/FIRLEAR>

FIRLEHY

Filter element for return filter HY



Temp. min.: -25 °C
 Temp. max.: 120 °C
 Material: Gasket: NBR
 Operating pressure: Max. 20 bar

Identification	Filter mesh size µm	Filter area cm ²	Filter material	Ø A mm	Ø B mm	Ø C mm	L mm	L1 mm	Weight kg
FI RLEHY 0100 A10	10,0	8785	inorganic	114,0	68,3	65,0	331,00	312,50	2,44
FI RLEHY 0050 A16	16,0	610	inorganic	51,5	24,0	22,0	102,50	91,50	0,23

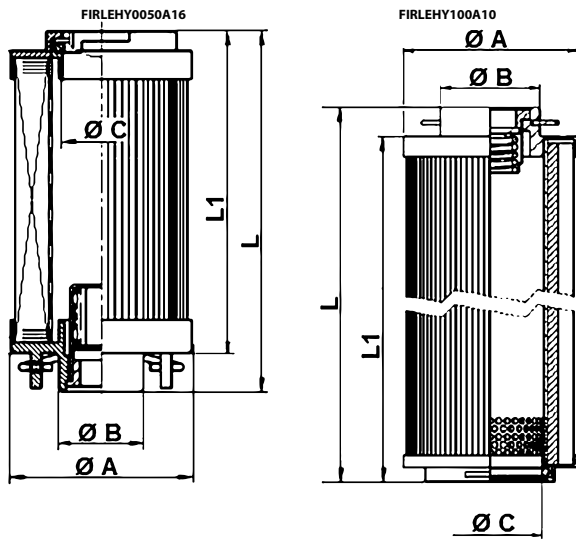

Web: <http://cat.hansa-flex.com/en/FIRLEHY>

FI RLV

Tube extension for return flow filter

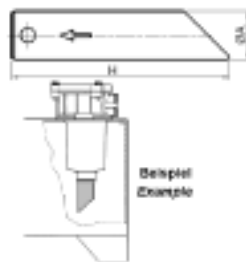

For extending the filter outlet from return-flow filters in the tank
 reduction of swirling of the returning oil
 Can be individually shortened

Material: Polyamide
Use: For return flow filter FI RL

Identification	for filter type	Ø A mm	H mm	Weight kg
FI RLV 25 300	FI RL 024, 048	25	300	0,2
FI RLV 32 500	FI RL 053, 064, 086, 110, 150	32	500	0,4
FI RLV 40 300	FI RL 125, 225	40	300	0,6
FI RLV 40 500	FI RL 180, 230	40	500	0,8

Web: <http://cat.hansa-flex.com/en/FIRLRVL>

Accessory for following products:

- FI RL - Return flow filters
- FI RL GEH - Housing for return flow filter

FI SP R 1

Spin-on return flow filter type 1

Spin-on filters for pipeline installation

Pressure differential for paper filter element (P) max. 4 bar

Pressure differential for filter inorganic element (A) max. 4 bar

Design (Qmax.) for medium ISO VG 46

at 50°C (30 mm²/s) at $\Delta p_{tot} = 0.4$ bar

Design: with bypass valve 1.75 bar

Temp. min.: -25 °C

Temp. max.: 110 °C

Material: Filter head in aluminum, Gasket: NBR

Operating pressure: max. 12 bar

Filter mesh size: 10 μ m

Note: For utilization as a suction filter a suction filter head FI SP S FK *** must be used.

Ordering information: Other filter materials and filters for other types of oil, viscosities or temperatures available on request

Identification	Filter area cm ²	Filter material	Line connection	Q max. L/min	B mm	D mm	Ø A mm	L mm	L1 mm	Weight kg
FI SP R 48 A10 V G3/4	1900	inorganic	G 3/4"	48	22	95	96,0	180,0	200,0	1,0
FI SP R 55 P10 V G3/4	2240	organic	G 3/4"	55	22	95	96,0	180,0	200,0	1,0
FI SP R 53 A10 V G3/4	3160	inorganic	G 3/4"	53	22	95	96,0	248,0	268,0	1,3
FI SP R 58 P10 V G3/4	4140	organic	G 3/4"	58	22	95	96,0	248,0	268,0	1,3
FI SP R 110 A10 V G11/4	3950	inorganic	G 1.1/4"	110	30	133	129,0	241,0	266,0	2,2
FI SP R 130 P10 V G11/4	4300	organic	G 1.1/4"	130	30	133	129,0	241,0	266,0	2,2
FI SP R 115 A10 V G11/4	5390	inorganic	G 1.1/4"	115	30	133	129,0	286,0	311,0	2,3
FI SP R 150 P10 V G11/4	5760	organic	G 1.1/4"	150	30	133	129,0	286,0	311,0	2,3

Qmax - max intake volumetric flow

Web: <http://cat.hansa-flex.com/en/FISPR1>

Spare parts:

FI SP E MP - Filter element for spin-on filter MP

FI SP R/S FK - Filter head for spin-on return flow filter / suction filter

Accessories:

HK VA MAN - Clogging indicator pressure gauge

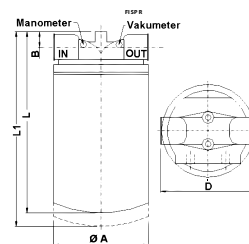

2

FI SP R 2

Spin-on return flow filter type 2

Spin-on filters for pipeline installation

Pressure differential for paper filter element (P) max. 4 bar

Pressure differential for filter inorganic element (A) max. 4 bar

Design (Qmax.) for medium ISO VG 46

at 50°C (30 mm²/s) at $\Delta p_{tot} = 0.4$ bar

Design: as return filter, with bypass valve 1.75 bar, without clogging indicator

Temp. min.: -25 °C

Temp. max.: 110 °C

Material: Filter head in aluminum, Gasket: NBR

Operating pressure: max. 12 bar

Filter mesh size: 10 μ m

Note: For utilization as a suction filter a suction filter head FI SP S FK *** must be used.

Ordering information: Other filter materials and filters for other types of oil, viscosities or temperatures available on request

Identification	Filter area cm ²	Filter material	Line connection	Q max. L/min	A mm	C mm	D mm	E mm	Weight kg
FI SP R 215 A10 V G11/2	2 x 3160	inorganic	G 1.1/2"	220	216	241	140	129	4,0
FI SP R 280 P10 V G11/2	2 x 4300	organic	G 1.1/2"	282	216	241	140	129	4,0
FI SP R 250 A10 V G11/2	2 x 5390	inorganic	G 1.1/2"	250	261	286	140	129	4,2
FI SP R 290 P10 V G11/2	2 x 5760	organic	G 1.1/2"	293	261	286	140	129	4,2

Qmax - max intake volumetric flow

Web: <http://cat.hansa-flex.com/en/FISPR2>

Spare parts:

FI SP E MP - Filter element for spin-on filter MP

FI SP R/S FK - Filter head for spin-on return flow filter / suction filter

Accessories:

HK VA MAN - Clogging indicator pressure gauge

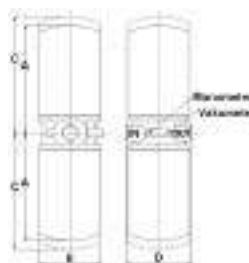

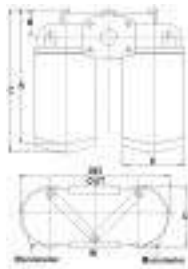
FI SP R 3
Spin-on return flow filter type 3

Spin-on filters for pipeline installation

Pressure differential for paper filter element (P) max. 4 bar

Pressure differential for filter inorganic element (A) max. 4 bar

Design (Qmax.) for medium ISO VG 46

at 50°C (30 mm²/s) at $\Delta p_{tot} = 0.4$ bar

Design: as return filter, with bypass valve 1.75 bar, without clogging indicator

Temp. min.: -25 °C

Temp. max.: 110 °C

Material: Filter head in aluminum, Gasket: NBR

Operating pressure: max. 12 bar

Filter mesh size: 10 µm

Note: For utilization as a suction filter a suction filter head FI SP S FK *** must be used.

Ordering information: Other filter materials and filters for other types of oil, viscosities or temperatures available on request

Identification	Filter area	Filter material	Line connection	Q max. L/min	A mm	B mm	C mm	D mm	E mm	Weight kg
FI SP R 220 A10 V G11/2	2 x 3950 cm ²	inorganic	G 1.1/2"	220	265	47	290	130	129	5,4
FI SP R 282 P10 V G11/2	2 x 4300 cm ²	organic	G 1.1/2"	282	265	47	290	130	129	5,4
FI SP R 220 A10 V SAE112	2 x 3950 cm ²	inorganic	1.1/2" SAE 3000 PSI/M	220	265	47	290	130	129	5,4
FI SP R 282 P10 V SAE112	2 x 4300 cm ²	organic	1.1/2" SAE 3000 PSI/M	282	265	47	290	130	129	5,4
FI SP R 255 A10 V G11/2	2 x 5390 cm ²	inorganic	G 1.1/2"	250	310	47	335	130	129	5,6
FI SP R 293 P10 V G11/2	2 x 5760 cm ²	organic	G 1.1/2"	293	310	47	335	130	129	5,4
FI SP R 255 A10 V SAE112	2 x 5390 cm ²	inorganic	1.1/2" SAE 3000 PSI/M	250	310	47	335	130	129	5,6
FI SP R 293 P10 V SAE112	2 x 5760 cm ²	organic	1.1/2" SAE 3000 PSI/M	293	310	47	335	130	129	5,6

Qmax - max intake volumetric flow

Web: <http://cat.hansa-flex.com/en/FISPR3>

Spare parts:

FI SP E MP - Filter element for spin-on filter MP

FI SP R/S FK - Filter head for spin-on return flow filter / suction filter

Accessories:

HK VA MAN - Clogging indicator pressure gauge

Filter head for spin-on return flow filter / suction filter

With these filter heads, spin-on filters can be used as return flow filters (R) or suction filters (S)

Opening pressure of bypass valve for return filter (R): 1.75 bar

Opening pressure of bypass valve for suction filter (S): 0.3 bar

Material: Aluminium

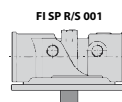

Identification	for filter type	Line connection	Design	Weight kg
FI SP R FK 001 G3/4	FI SP R 1 (R) with G 3/4" connection	G 3/4"	as return filter	0,36
FI SP R FK 001 G1 1/4	FI SP R 1 (R) with G 1 1/4" connection	G 1.1/4"	as return filter	1,00
FI SP R FK 002 G1 1/2	FI SP R 2 (R) with G 1 1/2" connection	G 1.1/2"	as return filter	1,22
FI SP R FK 003 G1 1/2	FI SP R 3 (R) with G 1 1/2" connection	G 1.1/2"	as return filter	2,86
FI SP R FK 003 SAE1 1/2	FI SP R 3 (R) with SAE 1 1/2" connection	1.1/2" SAE 3000 PSI/M	as return filter	2,86
FI SP S FK 001 G3/4	FI SP R 1 (S) with G 3/4" connection	G 3/4"	as suction filter	0,36
FI SP S FK 001 G1 1/4	FI SP R 1 (S) with G 1 1/4" connection	G 1.1/4"	as suction filter	0,50
FI SP S FK 002 G1 1/2	FI SP R 2 (S) with G 1 1/2" connection	G 1.1/2"	as suction filter	1,22
FI SP S FK 003 G1 1/2	FI SP R 3 (S) with G 1 1/2" connection	G 1.1/2"	as suction filter	2,86
FI SP S FK 003 SAE1 1/2	FI SP R 3 (S) with SAE 1 1/2" connection	1.1/2" SAE 3000 PSI/M	as suction filter	2,86

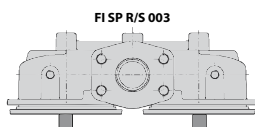
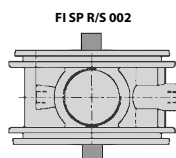

Web: <http://cat.hansa-flex.com/en/FISPRSEFK>

Spare part for following products:

FI SP R 1 - Spin-on return flow filter type 1

FI SP R 2 - Spin-on return flow filter type 2

FI SP R 3 - Spin-on return flow filter type 3

Additional elements:

FI SP E MP - Filter element for spin-on filter MP

FI SP E MP

Filter element for spin-on filter MP

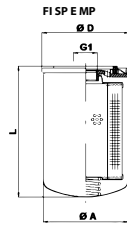
Special features:

Temp. min.:	-25 °C
Temp. max.:	120 °C
Material:	Gasket: NBR
Operating pressure:	max. 12 bar
Use:	For spin-on filters FI SP R 1, FI SP R 2, FI SP R 3

Identification	Filter mesh size	Filter area cm ²	Qmax L/min	Filter material	for filter type	G1	Ø A mm	Ø D mm	L mm	Weight kg
	µm									
FI SP E MP 0147 A10	10,0	2419	100	inorganic	FI SP R 48, 55	G 3/4"	95,0	96,0	147,0	0,70
FI SP E MP 0147 P10	10,0	2419	100	organic	FI SP R 48, 55	G 3/4"	95,0	96,0	147,0	0,60
FI SP E MP 0213 A10	10,0	3975	100	inorganic	FI SP R 53, 58	G 3/4"	96,0	97,0	213,0	0,90
FI SP E MP 0213 P10	10,0	3975	100	organic	FI SP R 53, 58	G 3/4"	96,0	97,0	213,0	0,80
FI SP E MP 0210 P25	25,0	3875	100	organic	FI SP R 53, 58	G 3/4"	96,0	97,0	213,0	0,80
FI SP E MP 0182 A10	10,0	5076	300	inorganic	FI SP R 110, 130, 215, 280, 220, 282	G 1.1/4"	129,0	130,0	182,0	1,30
FI SP E MP 0182 P10	10,0	5076	300	organic	FI SP R 110, 130, 215, 280, 220, 282	G 1.1/4"	129,0	130,0	182,0	1,20
FI SP E MP 0228 A06	6,0	6358	300	inorganic	FI SP R 115, 150, 250, 290, 255, 293	G 1.1/4"	129,0	130,0	228,0	1,47
FI SP E MP 0228 A10	10,0	6358	300	inorganic	FI SP R 115, 150, 250, 290, 255, 293	G 1.1/4"	129,0	130,0	228,0	1,47
FI SP E MP 0228 P10	10,0	6732	300	organic	FI SP R 115, 150, 250, 290, 255, 293	G 1.1/4"	129,0	130,0	228,0	1,36

Qmax - max intake volumetric flow

Web: <http://cat.hansa-flex.com/en/FISPEMP>

Spare part for following products:

- FI SP R 1 - Spin-on return flow filter type 1
- FI SP R 2 - Spin-on return flow filter type 2
- FI SP R 3 - Spin-on return flow filter type 3

Accessories:

FI SP R/S FK - Filter head for spin-on return flow filter / suction filter

FI SP E HE

Filter element for spin-on filter HE

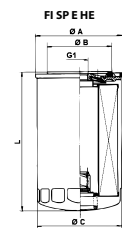

Temp. min.:	-25 °C
Temp. max.:	120 °C
Material:	Gasket: NBR
Operating pressure:	max. 12 bar

Identification	Filter mesh size	Filter material	G1	Ø A mm	Ø B mm	Ø C mm	L mm	Weight kg
	µm							
FI SP E HE 0260 P15	15,0	organic	1.1/8"-12 UNF	110,0	93,0	107,9	260,9	1,18

Qmax - max intake volumetric flow

Web: <http://cat.hansa-flex.com/en/FISPEHE>

FISPEHY

Filter element for spin-on filter HY

Temp. min.: -25 °C
 Temp. max.: 120 °C
 Material: Gasket: NBR
 Operating pressure: max. 4 bar

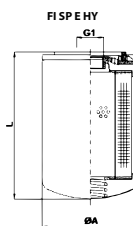

Identification	Filter mesh size µm	Filter area cm ²	Filter material	G1	Ø A mm	L mm	Weight kg
FI SP E HY 0020 P25	25,0	5078	organic	G 1.1/4"	129,0	182,0	0,50
Qmax - max intake volumetric flow							

Web: <http://cat.hansa-flex.com/en/FISPEHY>

FISPEMA

Filter element for spin-on filter MA

Temp. min.: -25 °C
 Temp. max.: 120 °C
 Material: Gasket: NBR
 Operating pressure: max. 12 bar



Identification	Filter mesh size µm	Filter material	G1	Ø A mm	Ø B mm	Ø C mm	L mm	Weight kg
FI SP E MA 0004 P20	20,0	organic	1.1/8" -16 UN	108,0	93,0	103,0	261,0	0,42
Qmax - max intake volumetric flow								

Web: <http://cat.hansa-flex.com/en/FISPEMA>

FISPESO

Filter element for spin-on filter SO

Temp. min.: -25 °C
 Temp. max.: 120 °C
 Material: Gasket: NBR
 Operating pressure: max. 4 bar



Identification	Filter mesh size µm	Filter area cm ²	Filter material	G1	Ø A mm	L mm	Weight kg
FI SP E SO 0010 M60	60,0	2992	wire mesh	G 1.1/4" -11	129,0	228,0	0,65
FI SP E SO 0010 P25	25,0	6732	organic	M 42 x 2	129,0	228,0	0,65
Qmax - max intake volumetric flow							

Web: <http://cat.hansa-flex.com/en/FISPESO>

FI HD 400
High pressure filter 400bar

Pressure filter for pipeline installation
 Pressure differential for filter element inorganic (A) max. 210 bar
 Connector for clogging indicator G 1/8" closed with bolt
Design: without bypass valve, without clogging indicator
Temp. min.: -10 °C
Temp. max.: 120 °C
Material: Filter head of GGG
Operating pressure: up to 400 bar
Scope of supply: incl. filter element

Note: Dimension "L": clearance required for changing the filter element

Identification	Filter mesh size µm	Filter area cm ²	G1	Q max. L/min	L mm	L1 mm	L2 mm	Ø A mm	Ø B mm	BD bar	AF mm	Weight kg
FI HD 040 A06 N 001 G12	6,0	470	G 1/2"	40	80,0	189,0	31,0	92,0	66,0	400	27	3,9
FI HD 050 A10 N 001 G12	10,0	470	G 1/2"	50	80,0	189,0	31,0	92,0	66,0	400	27	3,9
FI HD 070 A06 N 001 G34	6,0	900	G 3/4"	70	80,0	267,0	31,0	92,0	66,0	400	27	4,2
FI HD 090 A10 N 001 G34	10,0	900	G 3/4"	90	80,0	267,0	31,0	92,0	66,0	400	27	4,2
FI HD 085 A06 N 001 G34	6,0	1275	G 3/4"	85	80,0	343,0	31,0	92,0	66,0	400	27	5,7
FI HD 100 A10 N 001 G34	10,0	1275	G 3/4"	100	80,0	343,0	31,0	92,0	66,0	400	27	5,7
FI HD 170 A06 N 001 G114	6,0	2010	G 1.1/4"	170	110,0	284,0	46,0	143,5	109,0	400	30	9,4
FI HD 150 A10V N 010	10,0	2010	G 1.1/4"	195	110,0	284,0	46,0	143,5	109,0	400	30	6,0
FI HD 260 A06 N 001 G114	6,0	3800	G 1.1/4"	260	110,0	409,0	46,0	143,5	109,0	400	30	16,5
FI HD 300 A10 N 001 G114	10,0	3800	G 1.1/4"	300	110,0	409,0	46,0	143,5	109,0	400	30	16,5

Qmax - max intake volumetric flow A10 with inorganic filter (10 µm), absolute filtration P10 paper filter (10 µm), nominal filtration BD = Working pressure

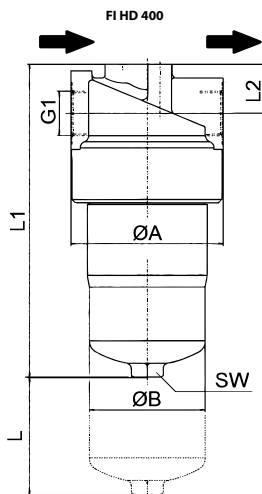

Web: <http://cat.hansa-flex.com/en/FIHD400>

Spare parts:

FI HD E MA - Filter element for high-pressure filter MA

FI HD GEH - High pressure filter 400bar

Accessories:

HK VA PIS M - Clogging indicator mechanical

HK VA PIS EL - Clogging indicator electrical

FI HD GEH

High pressure filter 400bar

Pressure filter for pipeline installation

Connector for clogging indicator G 1/8" closed with bolt

Design: without bypass valve, without clogging indicator

Temp. min.: -10 °C

Temp. max.: 120 °C

Material: Filter head of GGG

Operating pressure: up to 400 bar

Scope of supply: without filter element

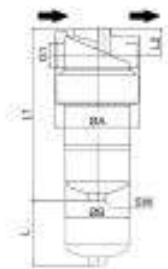

Note: Dimension "L": clearance required for changing the filter element

Ordering information: Filter element is not included. Please order separately.

Identification	for filter type	G1	L mm	L1 mm	L2 mm	Ø A mm	Ø B mm	BD bar	AF mm	Weight kg
FI HD GEH N 040 050 G12	FI HD 040, 050	G 1/2"	80,0	189,0	31,0	92,0	66,0	400	27	3,6
FI HD GEH N 070 090 G34	FI HD 070, 090	G 3/4"	80,0	267,0	31,0	92,0	66,0	400	27	3,9
FI HD GEH N 085 100 G34	FI HD 085, 100	G 3/4"	80,0	343,0	31,0	92,0	66,0	400	27	5,1
FI HD GEH N 170 195 G114	FI HD 150, 170	G 1.1/4"	110,0	284,0	46,0	143,5	109,0	400	30	8,5
FI HD GEH N 260 300 G114	FI HD 260, 300	G 1.1/4"	110,0	409,0	46,0	143,5	109,0	400	30	15,3

BD = Working pressure

Web: <http://cat.hansa-flex.com/en/FIHDGEH>

Spare part for following products:

FI HD 400 - High pressure filter 400bar

Accessories:

HK VA PIS M - Clogging indicator mechanical

HK VA PIS EL - Clogging indicator electrical

Additional elements:

FI HD E MA - Filter element for high-pressure filter MA

FI MD 315
Medium pressure filter 315 bar

Pressure filter for pipeline installation
 Pressure differential for filter element inorganic (A) max. 210 bar
 Connector for clogging indicator G 1/8" closed with bolt
Design: without bypass valve, without clogging indicator
Temp. min.: -10 °C
Temp. max.: 120 °C
Material: Filter head of GGG
Operating pressure: up to 315 bar
Scope of supply: incl. filter element

Note: Dimension "L": clearance required for changing the filter element

Identification	Filter mesh size µm	Filter area cm ²	Qmax L/min	G1	L mm	L1 mm	L2 mm	Ø A mm	Ø B mm	BD bar	AF mm	Weight kg
FI MD 040 A06 N 001 G12	6,0	425	40	G 1/2"	80,0	189,0	31,0	92,0	66,0	315	27	3,90
FI MD 050 A10V N 010	10,0	425	50	G 1/2"	80,0	189,0	31,0	92,0	66,0	315	27	4,10
FI MD 060 A06 N 001 G34	6,0	850	60	G 3/4"	80,0	267,0	31,0	92,0	66,0	315	27	4,20
FI MD 080 A10V N 010	10,0	850	75	G 3/4"	80,0	267,0	31,0	92,0	66,0	315	27	5,15
FI MD 080 A06 N 001 G34	6,0	1275	80	G 3/4"	80,0	343,0	31,0	92,0	66,0	315	27	5,70
FI MD 090 A10 N 001 G34	10,0	1275	90	G 3/4"	80,0	343,0	31,0	92,0	66,0	315	27	5,70
FI MD 170 A06 N 001 G114	6,0	2010	170	G 1.1/4"	110,0	257,0	32,0	142,0	109,0	210	30	9,40
FI MD 190 A10 N 001 G114	10,0	2010	190	G 1.1/4"	110,0	257,0	32,0	142,0	109,0	210	30	9,40
FI MD 240 A06 N 001 G114	6,0	3800	240	G 1.1/4"	110,0	371,0	32,0	142,0	109,0	210	30	16,50
FI MD 260 A10 N 001 G114	10,0	3800	260	G 1.1/4"	110,0	371,0	32,0	142,0	109,0	210	30	16,50

Qmax - max intake volumetric flow A10 with inorganic filter (10 µm), absolute filtration P10 paper filter (10 µm), nominal filtration BD = Working pressure

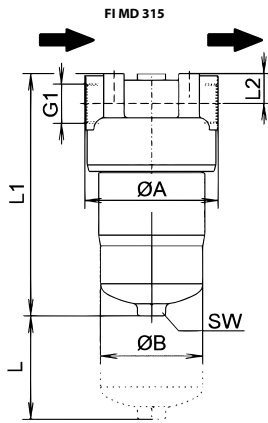

Web: <http://cat.hansa-flex.com/en/FIMD315>

Spare parts:

FI HD E MA - Filter element for high-pressure filter MA

FI MD GEH - High pressure filter 400bar

Accessories:

HK VA PIS M - Clogging indicator mechanical

HK VA PIS EL - Clogging indicator electrical

High pressure filter 400bar

Pressure filter for pipeline installation

Connector for clogging indicator G 1/8" closed with bolt

Design: without bypass valve, without clogging indicator

Temp. min.: -10 °C

Temp. max.: 120 °C

Material: Filter head of GGG

Operating pressure: up to 315 bar

Scope of supply: without filter element



Note: Dimension "L": clearance required for changing the filter element

Ordering information: Filter element is not included. Please order separately.

Identification	for filter type	G1	L mm	L1 mm	L2 mm	Ø A mm	Ø B mm	BD bar	AF mm	Weight kg
FI MD GEH N 040 050 G12	FI MD 040, 050	G 1/2"	80,0	189,0	31,0	92,0	66,0	315	27	3,60
FI MD GEH N 060 075 G34	FI MD 060, 080	G 3/4"	80,0	267,0	31,0	92,0	66,0	315	27	3,90
FI MD GEH N 080 090 G34	FI MD 080, 090	G 3/4"	80,0	343,0	31,0	92,0	66,0	315	27	5,10
FI MD GEH N 170 190 G114	FI MD 170, 190	G 1.1/4"	110,0	257,0	32,0	142,0	109,0	210	27	8,50
FI MD GEH N 240 260 G114	FI MD 240, 260	G 1.1/4"	110,0	371,0	32,0	142,0	109,0	210	30	15,30

BD = Working pressure

Web: <http://cat.hansa-flex.com/en/FIMDGEH>

Spare part for following products:

FI MD 315 - Medium pressure filter 315 bar

Accessories:

HK VA PIS M - Clogging indicator mechanical

HK VA PIS EL - Clogging indicator electrical

Additional elements:

FI HD E MA - Filter element for high-pressure filter MA

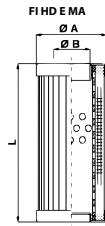
FI HD E MA
Filter element for high-pressure filter MA

Special features: amplified version, Δp max. 20 bar
Temp. min.: -25 °C
Temp. max.: 120 °C
Material: Gasket: NBR
Operating pressure: max. 210 bar
Use: For pressure filters FI MD 315, FI HD 400

Identification	Filter mesh size	Filter area cm ²	Q _{max} L/min	Filter material	for filter type	L mm	Ø A mm	Ø B mm	Weight kg
	µm								
FI HD E MA 0050 A06V	6,0	470	40	inorganic	FI HD 040, 050 / FI MD 040, 050	94,0	47,0	25,5	0,26
FI HD E MA 0050 A10V	10,0	470	50	inorganic	FI HD 040, 050 / FI MD 040, 050	94,0	47,0	25,5	0,24
FI HD E MA 0090 A06V	6,0	900	70	inorganic	FI HD 070, 090 / FI MD 060, 080	172,0	47,0	25,5	0,45
FI HD E MA 0090 A10V	10,0	900	90	inorganic	FI HD 070, 090 / FI MD 060, 080	172,0	47,0	25,5	0,40
FI HD E MA 0110 A06V	6,0	1275	85	inorganic	FI HD 085, 100 / FI MD 080, 090	294,0	47,0	25,5	0,60
FI HD E MA 0110 A10V	10,0	1275	110	inorganic	FI HD 085, 100 / FI MD 080, 090	294,0	47,0	25,5	0,55
FI HD E MA 0150 A06V	6,0	2010	170	inorganic	FI HD 150, 170 / FI MD 170, 190	144,0	83,2	47,5	1,05
FI HD E MA 0150 A10V	10,0	2010	195	inorganic	FI HD 150, 170 / FI MD 170, 190	144,0	83,2	47,5	0,84
FI HD E MA 0300 A06V	6,0	3800	240	inorganic	FI HD 260, 300 / FI MD 240, 260	258,0	83,2	47,5	1,64
FI HD E MA 0300 A10V	10,0	3800	260	inorganic	FI HD 260, 300 / FI MD 240, 260	258,0	83,2	47,5	1,60

Q_{max} - max intake volumetric flow

Web: <http://cat.hansa-flex.com/en/FIHDEMA>

Spare part for following products:

FI MD 315 - Medium pressure filter 315 bar

FI HD 400 - High pressure filter 400bar

Accessory for following products:

FI MD GEH - High pressure filter 400bar

FI HD GEH - High pressure filter 400bar

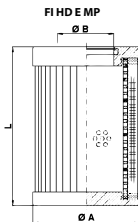
FI HD E MP
Filter element for high-pressure filter MP

Special features: Δp max. 20 bar
Temp. min.: -25 °C
Temp. max.: 120 °C
Material: Gasket: NBR
Operating pressure: max. 210 bar

Identification	Filter mesh size	Filter area cm ²	Q _{max} L/min	Filter material	L mm	Ø A mm	Ø B mm	Weight kg
	µm							
FI HD E MP 0078 A10	10,0	300	80	inorganic	76,5	52,0	24,0	0,21
FI HD E MP 0086 A05	5,0	399	34	inorganic	86,0	45,0	25,4	0,20
FI HD E MP 0086 A10	10,0	399	60	inorganic	86,0	45,0	25,4	0,20
FI HD E MP 0114 A05	5,0	550	58	inorganic	114,0	45,0	25,4	0,30
FI HD E MP 0114 A10	10,0	550	95	inorganic	114,0	45,0	25,4	0,30
FI HD E MP 0210 A05	5,0	1069	100	inorganic	210,0	45,0	25,4	0,42
FI HD E MP 0210 A10	10,0	1069	100	inorganic	210,0	45,0	25,4	0,42
FI HD E MP 0234 A05	5,0	1672	200	inorganic	234,0	51,0	27,1	0,60
FI HD E MP 0234 A10	10,0	1672	200	inorganic	234,0	51,0	27,1	0,60
FI HD E MP 0236 A05	5,0	2943	350	inorganic	236,0	78,0	40,2	1,30
FI HD E MP 0236 A10	10,0	2943	350	inorganic	236,0	78,0	40,2	1,30

Q_{max} - max intake volumetric flow

Web: <http://cat.hansa-flex.com/en/FIHDEMP>

FI HD E HY

Filter element for high-pressure filter HY

Special features: Δp max. 20 bar
Temp. min.: -25 °C
Temp. max.: 120 °C
Material: Gasket: NBR
Operating pressure: max. 210 bar

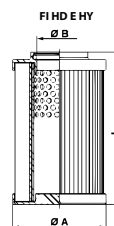

Identification	Filter mesh size	Filter area cm ²	Filter material	A	Ø B	Ø C	Weight kg
	µm			mm	mm	mm	
FI HD E HY 0050 A16	16,0	1275	inorganic	115,0	70,0	34,1	0,48
FI HD E HY 334 SP15	15,0	5840	synthetic polyester	334,0	94,5	81,5	1,15

Q_{max} - max intake volumetric flow

Web: <http://cat.hansa-flex.com/en/FIHDEHY>

FI ND E AR

Filter element for low-pressure filter AR

Temp. min.: -25 °C
Temp. max.: 120 °C
Material: Gasket: NBR
Operating pressure: Max. 10 bar

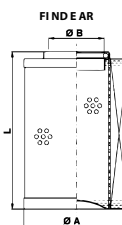

Identification	Filter mesh size	Filter area cm ²	Filter material	L	Ø A	Ø B	Weight kg
	µm			mm	mm	mm	
FI ND E AR 0039 P10	10,0	620	organic	104,0	45,5	20,5	0,10
FI ND E AR 165 A25	25,0	6295	inorganic	165,0	118,0	59,5	0,60

Q_{max} - max intake volumetric flow

Web: <http://cat.hansa-flex.com/en/FINDEAR>

FI ND E HY

Filter element for low-pressure filter HY

Temp. min.: -25 °C
Temp. max.: 120 °C
Material: Gasket: NBR
Operating pressure: Max. 10 bar

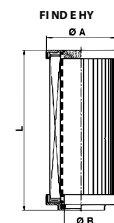

Identification	Filter mesh size	Filter area cm ²	Q _{max} L/min	Filter material	L	Ø A	Ø B	Weight kg
	µm				mm	mm	mm	
FI ND E HY 0050 A10	10,0	900	200	inorganic	153,0	47,0	22,1	0,24

Q_{max} - max intake volumetric flow

Web: <http://cat.hansa-flex.com/en/FINDEHY>

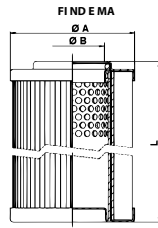
FI ND E MA
Filter element for low-pressure filter MA

Temp. min.: -25 °C
Temp. max.: 120 °C
Material: Gasket: NBR
Operating pressure: Max. 10 bar

Identification	Filter mesh size	Filter area cm ²	Q _{max} L/min	Filter material	L mm	Ø A mm	Ø B mm	Weight kg
	µm							
FI ND E MA 0093 A03	3,0	590	15	inorganic	93,0	47,0	25,5	0,20
FI ND E MA 0030 P25	25,0	1824	80	organic	178,0	58,0	32,2	0,27
FI ND E MA 0025 M60	60,0	1575	150	wire mesh	142,0	83,2	47,5	0,52
FI ND E MA 0050 A03	3,0	4020	200	inorganic	249,0	78,5	40,3	0,72
FI ND E MA 0050 A06	6,0	4020	200	inorganic	249,0	78,5	40,3	0,72
FI ND E MA 0050 A10	10,0	4020	200	inorganic	249,0	78,5	40,3	0,72
FI ND E MA 0060 M100	100,0	4280	300	wire mesh	265,5	83,2	47,5	0,98
FI ND E MA 0040 M60	60,0	2000	330	wire mesh	210,0	140,0	51,0	0,79
FI ND E MA 0045 P03	3,0	10000	350	organic	221,5	152,0	88,0	0,60
FI ND E MA 0100 M40	40,0	6370	450	wire mesh	372,0	83,2	47,5	0,98
FI ND E MA 0100 M60	60,0	4410	450	wire mesh	372,0	83,2	47,5	1,42
FI ND E MA 0463 A03	3,0	10650	350	inorganic	463,0	106,0	72,0	0,95
FI ND E MA 0463 A06	6,0	10650	400	inorganic	463,0	106,0	72,0	0,95
FI ND E MA 0463 A10	10,0	10650	450	inorganic	463,0	106,0	72,0	0,95

Q_{max} - max intake volumetric flow Filter FI ND E MA 0050 *** for Bypass flow filter system NSFA Typ D Filter FI ND E MA 0463 *** for Bypass flow filter system NSFA Typ E

Web: <http://cat.hansa-flex.com/en/FINDEMA>

Spare part for following products:

NSFA Typ D - Bypass flow filter system Type D

NSFA Typ E - Bypass flow filter system Type E

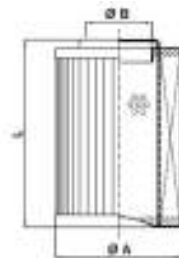
FI ND E MP
Filter element for low-pressure filter MP

Temp. min.: -25 °C
Temp. max.: 120 °C
Material: Gasket: NBR
Operating pressure: Max. 10 bar

Identification	Filter mesh size	Filter area cm ²	Filter material	L mm	Ø A mm	Ø B mm	Weight kg
	µm						
FI ND E MP 0040 A06	6,0	405	inorganic	90,0	42,0	22,8	0,15
FI ND E MP 0150 A10	10,0	2943	inorganic	375,0	78,0	40,5	0,70

Q_{max} - max intake volumetric flow

Web: <http://cat.hansa-flex.com/en/FINDEMP>

FINDEPL

Filter element for low-pressure filter PL

Temp. min.: -25 °C
 Temp. max.: 120 °C
 Material: Gasket: NBR
 Operating pressure: Max. 10 bar



Identification	Filter mesh size	Filter area cm ²	Filter material	L mm	Ø A mm	Ø B mm	Ø C mm	D mm	Weight kg
	µm								
FI ND E PL 0050 A03	3,0	5840	inorganic	329,0	81,0	43,7	43,0		1,30
FI ND E PL 0050 A06	6,0	5840	inorganic	329,0	81,0	43,7	43,0		1,30
FI ND E PL 0263 A03 V4.0	4,0	4406	inorganic	263,0	79,5	32,1		10	0,16

Qmax - max intake volumetric flow

FINDEPL0050A03, FINDEPL0050A06

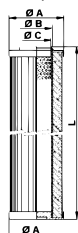

FINDEPL0263A03V4.0

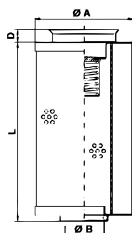

Web: <http://cat.hansa-flex.com/en/FINDEPL>

FINDES F

Filter element for low-pressure filter SF

Temp. min.: -25 °C
 Temp. max.: 120 °C
 Material: Gasket: NBR
 Operating pressure: Max. 10 bar

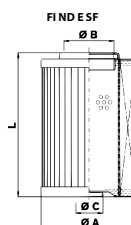

Identification	Filter mesh size	Filter area cm ²	Filter material	L mm	Ø A mm	Ø B mm	Ø C mm	Weight kg
	µm							
FI ND E SF 0090 A03	3,0	1297	inorganic	99,0	73,6	32,0	32,0	1,15

Qmax - max intake volumetric flow

Web: <http://cat.hansa-flex.com/en/FINDES F>

FI ND E ST

Filter element for low-pressure filter ST

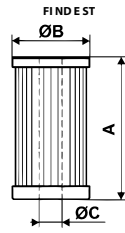

Temp. min.: -25 °C
Temp. max.: 120 °C
Material: Gasket: NBR
Operating pressure: Max. 10 bar

Identification	Filter mesh size µm	Filter material	A mm	Ø B mm	Ø C mm	Weight kg
FI ND E ST 0010 A06	6,0	inorganic	305,0	102,0	63,5	0,5

Qmax - max intake volumetric flow

Web: <http://cat.hansa-flex.com/en/FINDEST>

FI ND E UF

Filter element for low-pressure filter UF

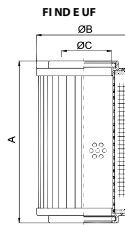

Temp. min.: -25 °C
Temp. max.: 120 °C
Material: Gasket: NBR
Operating pressure: Max. 10 bar

Identification	Filter mesh size µm	Filter area cm ²	Filter material	A mm	Ø B mm	Ø C mm	Weight kg
FI ND E UF 0010 A03	3,0	3260	inorganic fiberglass	210,0	99,0	51,5	1,00
FI ND E UF 0010 A06	6,0	3260	inorganic fiberglass	210,0	99,0	51,5	1,00
FI ND E UF 0011 A10	10,0	3260	inorganic fiberglass	210,0	99,0	51,5	0,58

for Bypass flow filter system NSFA Typ C

Web: <http://cat.hansa-flex.com/en/FINDEUF>

Spare part for following products:
 NSFA Typ C - Bypass flow filter system Type C

HK FI AD E0/EV

Adsorber filter single use without valve

These adsorber filters are used for the ventilation of hygroscopic substances of any kind.

Design:	Disposable with activated charcoal filter, Integrated filter element 3 µm
Connection:	at bottom
Installation position:	vertical
Temp. range:	-40 °C to +70 °C
Material:	Housing: Aluminium and acrylic, Gasket: NBR

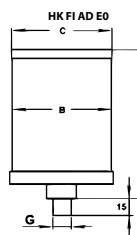

Note: Design bases are medium, air flow rate or clunk pick-up volume.

To replace the adsorber cartridge, the connector remains on the machine.

Other variants with housing in aluminum or stainless steel as well as for aggressive media are available on request.

Ordering information: For tank mounting the mounting flange HK FI AD FS must be ordered if necessary.

Identification	Design	Air volume L/min	for tank size	A mm	B mm	C mm	G	Weight kg
HK FI AD 005 E0 N AF	without valve	5	≤ 100 litres	164,0	90,0	96,0	G 3/4"	0,8
HK FI AD 010 E0 N AF	without valve	10	≤ 100 litres	222,0	90,0	96,0	G 3/4"	1,2
HK FI AD 020 E0 N AF	without valve	20	100 - 600 litres	238,0	110,0	116,0	G 3/4"	1,6
HK FI AD 040 E0 N AF	without valve	40	100 - 600 litres	338,0	110,0	116,0	G 3/4"	2,3
HK FI AD 100 E0 N AF	without valve	100	600 - 1800 litres	253,0	150,0	156,0	G 1"	3,2
HK FI AD 180 E0 N AF	without valve	180	600 - 1800 litres	353,0	150,0	156,0	G 1"	4,8
HK FI AD 005 EV N AF	with valve	5	≤ 100 litres	164,0	90,0	96,0	G 3/4"	0,8
HK FI AD 010 EV N AF	with valve	10	≤ 100 litres	222,0	90,0	96,0	G 3/4"	1,2
HK FI AD 020 EV N AF	with valve	20	100 - 600 litres	238,0	110,0	116,0	G 3/4"	1,6
HK FI AD 040 EV N AF	with valve	40	100 - 600 litres	338,0	110,0	116,0	G 3/4"	2,3
HK FI AD 100 EV N AF	with valve	100	600 - 1800 litres	253,0	150,0	156,0	G 1"	3,2
HK FI AD 180 EV N AF	with valve	180	600 - 1800 litres	353,0	150,0	156,0	G 1"	4,8

Air volume: Recommended air throughput for optimum drying efficiency

Web: <http://cat.hansa-flex.com/en/HKFIAD E0EV>

Additional info: In the adsorber the water molecules contained in the air are bounded in the pores of the adsorbent (silica gel). The saturation (charging) and then the necessary replacement of the filter cartridge is indicated by a color change from orange to green. The valve system prevents unnecessary water absorption from the ambient air during the standstill times. This allows longer service lives of the adsorbent filling. Silica gel consists of about 99 % of silicon dioxide (SiO₂) and is classified as a synthetic polar and hydrophilic desiccant. It possesses due to its high porosity, a large internal surface area of up to 800 m²/g. This enables a very high water holding capacity.

In adsorber filters silica gel is often added with a color indicator. Color changes indicate the water content and therefore the progress of the loading of the desiccant.

According to EU legislation (Regulation EC No 1272/2008) silica gel is not classified as a dangerous substance. It is not subject to classification according to EC Directives (67/548/EEC and 1999/45/EC). Silica gel is not among the health and environmentally hazardous substances.

Spare parts:

HK FI AD ET - Filter element for single use adsorber

Accessories:

HK FI AD FS - Mounting flange for adsorber

HK FI AD FS BY - Mounting flange for adsorber

HK FI AD FS FILL - Mounting flange for adsorber

HK FI AD MV

Adsorber filter reusable with valve

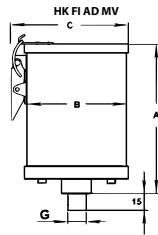

Design: Reusable with activated charcoal filter, with valves, integrated filter element 3 µm
Connection: at bottom
Installation position: vertical
Temp. range: -40 °C to +70 °C
Material: Housing: Aluminium and acrylic, Gasket: NBR

Note: Design bases are medium, air flow rate or clunk pick-up volume.
 Other variants with housing in aluminum or stainless steel as well as for aggressive media are available on request.

Ordering information: For tank mounting the mounting flange HK FI AD FS must be ordered if necessary.

Identification	Air volume L/min	for tank size	A mm	B mm	C mm	G	Weight kg
HK FI AD 005 MV N AF	5	≤ 100 litres	173,0	90,0	128,0	G 3/4"	1,0
HK FI AD 010 MV N AF	10	≤ 100 litres	231,0	90,0	128,0	G 3/4"	1,3
HK FI AD 020 MV N AF	20	100 - 600 litres	245,0	110,0	149,0	G 3/4"	1,8
HK FI AD 040 MV N AF	40	100 - 600 litres	345,0	110,0	149,0	G 3/4"	2,5
HK FI AD 100 MV N AF	100	600 - 1800 litres	260,0	150,0	187,0	G 1"	3,5
HK FI AD 180 MV N AF	180	600 - 1800 litres	360,0	150,0	187,0	G 1"	5,1

Air volume: Recommended air throughput for optimum drying efficiency

Web: <http://cat.hansa-flex.com/en/HKFIADMV>

Additional info: In the adsorber the water molecules contained in the air are bounded in the pores of the adsorbent (silica gel). The saturation (charging) and then the necessary replacement of the filter cartridge is indicated by a color change from orange to green. The desing of the reusable adsorber filters, in combination with the activated carbon allows an unlimited number of regenerations of the adsorbents. Additionally, the valve system protects against unnecessary water uptake from the ambient air during the downtime. This allows longer periods of use. Silica gel consists of about 99 % of silicon dioxide (SiO₂) and is classified as a synthetic polar and hydrophilic desiccant. It possesses due to its high porosity, a large internal surface area of up to 800 m²/g. This enables a very high water holding capacity. In adsorber filters silica gel is often added with a color indicator. Color changes indicate the water content and therefore the progress of the loading of the desiccant. According to EU legislation (Regulation EC No 1272/2008) silica gel is not classified as a dangerous substance. It is not subject to classification according to EC Directives (67/548/EEC and 1999/45/EC). Silica gel is not among the health and environmentally hazardous substances.

Spare parts:

- HK FI AD ETS - Refill-kit for reusable adsorber
- HK FI AD SK - Adsorbent silicagel

Accessories:

- HK FI AD FS - Mounting flange for adsorber
- HK FI AD FS BY - Mounting flange for adsorber
- HK FI AD FS FILL - Mounting flange for adsorber

HK FI AD MV VARIO PA

Adsorber filter reusable with valve

These reusable adsorber filters are used for the ventilation of hygroscopic substances of any kind.

Design: Reusable with activated charcoal filter, with valves, high quality valve system, Integrated filter element 3 µm, stable aluminium-base

Connection: at bottom

Installation position: vertical

Temp. range: -40 °C to +70 °C

Material: Housing: Aluminium and acrylic, Gasket: NBR

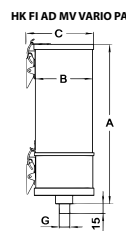

Note: Design bases are medium, air flow rate or clunk pick-up volume.

Other variants with housing in aluminum or stainless steel as well as for aggressive media are available on request.

Ordering information: For tank mounting the mounting flange HK FI AD FS must be ordered if necessary.

Identification	Air volume L/min	for tank size	A mm	B mm	C mm	G	Weight kg
HK FI AD 310 MV N AF VPA	20	100 - 600 litres	311,0	110,0	148,0	G 3/4"	2,3
HK FI AD 330 MV N AF VPA	40	100 - 600 litres	412,0	110,0	148,0	G 3/4"	3,0
HK FI AD 510 MV N AF VPA	100	600 - 1800 litres	329,0	150,0	187,0	G 1"	4,6
HK FI AD 560 MV N AF VPA	210	1800 - 3600 litres	549,0	150,0	187,0	G 1"	7,9

Air volume: Recommended air throughput for optimum drying efficiency

Web: <http://cat.hansa-flex.com/en/HKFIADMVVARIOPA>

Additional info: In the adsorber the water molecules contained in the air are bounded in the pores of the adsorbent (silica gel). The saturation (charging) and then the necessary replacement of the filter cartridge is indicated by a color change from orange to green. The desing of the reusable adsorber filters, in combination with the activated carbon allows an unlimited number of regenerations of the adsorbents. Additionally, the valve system protects against unnecessary water uptake from the ambient air during the downtime. This allows longer periods of use. Silica gel consists of about 99 % of silicon dioxide (SiO₂) and is classified as a synthetic polar and hydrophilic desiccant. It possesses due to its high porosity, a large internal surface area of up to 800 m²/g. This enables a very high water holding capacity. In adsorber filters silica gel is often added with a color indicator. Color changes indicate the water content and therefore the progress of the loading of the desiccant.

According to EU legislation (Regulation EC No 1272/2008) silica gel is not classified as a dangerous substance. It is not subject to classification according to EC Directives (67/548/EEC and 1999/45/EC). Silica gel is not among the health and environmentally hazardous substances.

Spare parts:

HK FI AD ETS - Refill-kit for reusable adsorber

HK FI AD SK - Adsorbent silicagel

Accessories:

HK FI AD FS - Mounting flange for adsorber

HK FI AD FS BY - Mounting flange for adsorber

HK FI AD FS FILL - Mounting flange for adsorber

HK FI AD ET

Filter element for single use adsorber



Design: Replacement cartridge without coupling, Type EV: with valves
Material: Housing: Aluminium and acrylic

Identification	for filter type	Weight kg
HK FI AD ET 005	HKFIAD005E0NAF	0,7
HK FI AD ET 010	HKFIAD010E0NAF	1,0
HK FI AD ET 020	HKFIAD020E0NAF	1,4
HK FI AD ET 040	HKFIAD040E0NAF	2,1
HK FI AD ET 100	HKFIAD100E0NAF	3,0
HK FI AD ET 180	HKFIAD180E0NAF	4,6
HK FI AD ET 005 EV	HKFIAD005EVNAF	0,7
HK FI AD ET 010 EV	HKFIAD010EVNAF	1,0
HK FI AD ET 020 EV	HKFIAD020EVNAF	1,4
HK FI AD ET 040 EV	HKFIAD040EVNAF	2,1
HK FI AD ET 100 EV	HKFIAD100EVNAF	3,0
HK FI AD ET 180 EV	HKFIAD180EVNAF	4,6

Web: <http://cat.hansa-flex.com/en/HKFIADET>

Additional info: Silica gel consists of about 99 % of silicon dioxide (SiO₂) and is classified as a synthetic polar and hydrophilic desiccant. It possesses due to its high porosity, a large internal surface area of up to 800 m²/g. This enables a very high water holding capacity.

In adsorber filters silica gel is often added with a color indicator. Color changes indicate the water content and therefore the progress of the loading of the desiccant.

According to EU legislation (Regulation EC No 1272/2008) silica gel is not classified as a dangerous substance. It is not subject to classification according to EC Directives (67/548/EEC and 1999/45/EC). Silica gel is not among the health and environmentally hazardous substances.

Spare part for following products:

HK FI AD E0/EV - Adsorber filter single use without valve

HK FI AD ETS

Refill-kit for reusable adsorber

Scope of supply: Adsorbent silicagel orange, Activated carbon filters, Sealing rings and O-rings, Dust filter element



Identification	for filter type	Weight kg
HK FI AD ETS 005	HKFIAD005MVNAF	0,6
HK FI AD ETS 010	HKFIAD010MVNAF	0,6
HK FI AD ETS 020	HKFIAD020MVNAF	1,0
HK FI AD ETS 040	HKFIAD040MVNAF	1,5
HK FI AD ETS 100	HKFIAD100MVNAF	2,2
HK FI AD ETS 180	HKFIAD180MVNAF	3,2
HK FI AD ETS 020 VPA	HKFIAD310MVNAFVPA	1,0
HK FI AD ETS 040 VPA	HKFIAD330MVNAFVPA	1,9
HK FI AD ETS 100 VPA	HKFIAD510MVNAFVPA	2,0
HK FI AD ETS 210 VPA	HKFIAD560MVNAFVPA	4,6

Web: <http://cat.hansa-flex.com/en/HKFIADETS>

Additional info: Silica gel consists of about 99 % of silicon dioxide (SiO₂) and is classified as a synthetic polar and hydrophilic desiccant. It possesses due to its high porosity, a large internal surface area of up to 800 m²/g. This enables a very high water holding capacity.

In adsorber filters silica gel is often added with a color indicator. Color changes indicate the water content and therefore the progress of the loading of the desiccant.

According to EU legislation (Regulation EC No 1272/2008) silica gel is not classified as a dangerous substance. It is not subject to classification according to EC Directives (67/548/EEC and 1999/45/EC). Silica gel is not among the health and environmentally hazardous substances.

Spare part for following products:

HK FI AD MV - Adsorber filter reusable with valve

HK FI AD MV VARIO PA - Adsorber filter reusable with valve

HK FI AD SK

Adsorbent silicagel



Note: for refilling of adsorber filters

Identification	Design	Weight kg
HK FI AD SK 025	2,5 kg bundle	2,6
HK FI AD SK 040	4,0 kg bundle	4,1
HK FI AD SK 250	25 kg bundle	27,0

Web: <http://cat.hansa-flex.com/en/HKFIADSK>

Additional info: Silica gel consists of about 99 % of silicon dioxide (SiO₂) and is classified as a synthetic polar and hydrophilic desiccant. It possesses due to its high porosity, a large internal surface area of up to 800 m²/g. This enables a very high water holding capacity.

In adsorber filters silica gel is often added with a color indicator. Color changes indicate the water content and therefore the progress of the loading of the desiccant.

According to EU legislation (Regulation EC No 1272/2008) silica gel is not classified as a dangerous substance. It is not subject to classification according to EC Directives (67/548/EEC and 1999/45/EC). Silica gel is not among the health and environmentally hazardous substances.

Spare part for following products:

HK FI AD MV - Adsorber filter reusable with valve

HK FI AD MV VARIO PA - Adsorber filter reusable with valve

HK FI AD FS

Mounting flange for adsorber



Mounting flange (hole circle 73 mm / according to DIN 24557) for attachment of adsorber filters

Material: Aluminium, Gasket: NBR

Scope of supply: inkl. O-ring and set of screws (6x M5 x 20)

Identification	G	Weight kg
HK FI AD FS 73 G34	G 3/4"	0,14
HK FI AD FS 73 G1	G 1"	0,14

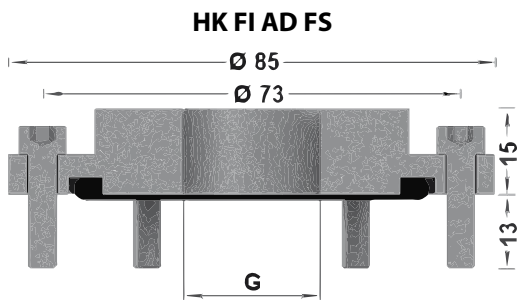

Web: <http://cat.hansa-flex.com/en/HKFIADFS>

Accessory for following products:

HK FI AD E0/EV - Adsorber filter single use without valve

HK FI AD MV - Adsorber filter reusable with valve

HK FI AD MV VARIO PA - Adsorber filter reusable with valve

HK FI AD FS FILL

Mounting flange for adsorber

Filling flange (pitch circle 73 mm in accordance with DIN 24557) for attaching adsorber filters. Furthermore, refilling with hydraulic oil can be done without the need to remove the filter.

Material: Aluminium, Stainless steel, Gasket: NBR

Scope of supply: including sieve, flat seal and screw set (6 No. M5 x 20)



Identification	G	Weight kg
HK FI AD FS 73 FILL G34	G 3/4"	0,9
HK FI AD FS 73 FILL G1	G 1"	0,9

2

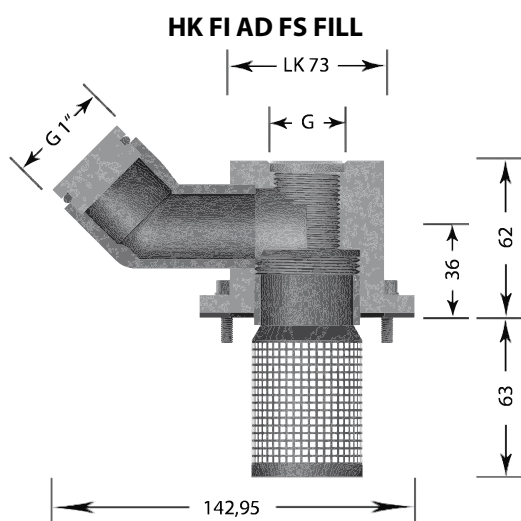

Web: <http://cat.hansa-flex.com/en/HKFIADFSFILL>

Accessory for following products:

HK FI AD E0/EV - Adsorber filter single use without valve

HK FI AD MV - Adsorber filter reusable with valve

HK FI AD MV VARIO PA - Adsorber filter reusable with valve

HK FI AD FS BY

Mounting flange for adsorber



Flange connection (pitch circle 41.3 or 73 mm in accordance with DIN 24557) for attaching adsorber filters. Furthermore, a bypass flow filter system can be connected without additional special fittings or the need to remove the filter.

Material: Aluminium, Gasket: NBR

Scope of supply: including side threaded connectors, seals and screw set (6 No. M5 x 100)

Identification	Design	A mm	B mm	G	G1	Weight kg
HK FI AD FS 41 BY 2 G12	2 bypass connections	41,3	62	G 1/2"	G 3/8"	0,9
HK FI AD FS 73 BY 1 G34	1 bypass connection	73,0	99	G 3/4"	G 3/4"	1,3
HK FI AD FS 73 BY 2 G34	2 bypass connections	73,0	99	G 3/4"	G 3/4"	1,3

HK FI AD FS BY

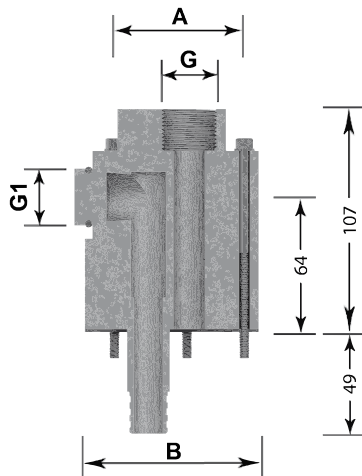

Web: <http://cat.hansa-flex.com/en/HKFIADFSBY>

Accessory for following products:

HK FI AD E0/EV - Adsorber filter single use without valve

HK FI AD MV - Adsorber filter reusable with valve

HK FI AD MV VARIO PA - Adsorber filter reusable with valve

HK VA MAN

Clogging indicator pressure gauge

Clogging display, pressure gauge version, for return flow, suction and pressure filters

Connection: G 1/8"



Note: Cannot be used for pressure filters FI HD 400, FI MD 315 or their housings FI HD GEH, FI MD GEH

Identification	Type	Design	Nominal size Ø	Weight kg
HK VA V1	Pressure gauge	Bottom connection	40	0,04
HK VA VR	Pressure gauge	Connection at rear	40	0,04
HK VA VS	vacuum pressure gauge for suction filter	Connection at rear	40	0,04

Web: <http://cat.hansa-flex.com/en/HKVAMAN>

Accessory for following products:

- FI RL - Return flow filters
- FI RL GEH - Housing for return flow filter
- FI SP R 1 - Spin-on return flow filter type 1
- FI SP R 2 - Spin-on return flow filter type 2
- FI SP R 3 - Spin-on return flow filter type 3
- FI SP R/S FK - Filter head for spin-on return flow filter / suction filter

HK VA EL

Clogging indicator electrical

Clogging display, electrical version, for return flow and pressure filters



Note: With the electric switches the switching point setting is "rising"
Cannot be used for pressure filters FI HD 400, FI MD 315 or their housings FI HD GEH, FI MD GEH

Identification	Thread	Type	Design	Dimensions	Switching point bar	Weight kg
HK VA FX	G 1/8"	elektrical, max. 250VAC	changeover contact	Height 74mm	1,3	0,06
HK VA N8	G 1/2"	elektrical, max. 115VDC	changeover contact	Height 65mm	7,0	0,16

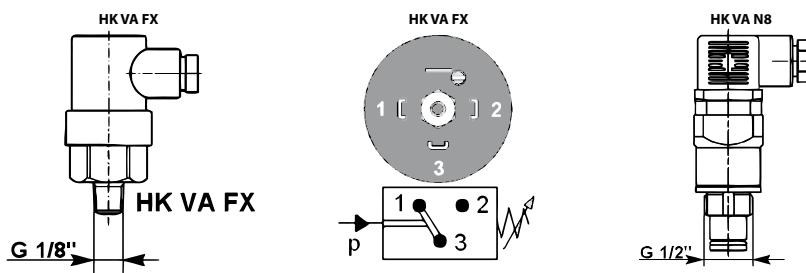

Web: <http://cat.hansa-flex.com/en/HKVAEL>

Accessory for following products:

- FI RL - Return flow filters
- FI RL GEH - Housing for return flow filter
- FI SP R 1 - Spin-on return flow filter type 1
- FI SP R 2 - Spin-on return flow filter type 2
- FI SP R 3 - Spin-on return flow filter type 3
- FI SP R/S FK - Filter head for spin-on return flow filter / suction filter

HK VA PIS M**Clogging indicator mechanical**

Clogging display, mechanical version, for pressure filters

Connection: M 20x1.5

Use: For pressure filters FI MD 315, FI HD 400

Identification	Type	Switching point bar	Weight kg
HK VA PIS 3095 5 M	optical	5,0	0,10

Web: <http://cat.hansa-flex.com/en/HKVAPISM>

Accessory for following products:

FI MD 315 - Medium pressure filter 315 bar

FI MD GEH - High pressure filter 400bar

FI HD 400 - High pressure filter 400bar

FI HD GEH - High pressure filter 400bar

HK VA PIS EL**Clogging indicator electrical**

Clogging display, electrical version, for pressure filters

Connection: M 20x1.5

Use: For pressure filters FI MD 315, FI HD 400

Note: The switching function can be changed (opener or closer) by replugging the electrical switching unit through 180°. The unit status is set as opener at the factory.

Identification	Type	Switching point bar	Weight kg
HK VA PIS 3092 5 EL	elektrical, max. 250VAC	5,0	0,25

Web: <http://cat.hansa-flex.com/en/HKVAPISEL>

Accessory for following products:

FI MD 315 - Medium pressure filter 315 bar

FI MD GEH - High pressure filter 400bar

FI HD 400 - High pressure filter 400bar

FI HD GEH - High pressure filter 400bar

HK FES DMM

Fluid sampling set, dynamic

The fluid sampling set is used for safely collecting fluid samples at measuring connections in hydraulic systems (even while the system is running). The equipment consists of several individual parts and is delivered fully assembled.

Application: General hydraulic systems

Connection 1: Measuring connection M 16 x 2



Note: Work on hydraulic systems must only be carried out by technically qualified personnel and compliance with the safety regulations in force.

The operating manual for this equipment must be followed to prevent injury to personnel and damage to the environment!

Identification	Weight kg	Max. working pressure bar
HK FES-DMM	0,75	315

Web: <http://cat.hansa-flex.com/en/HKFESDMM>

Additional elements:

HK PROBEF GL - Glass sample bottle

HK PROBEF LDPE - Plastic sample bottle

OELANALYSE SET 2 - Oil analysis set for mineral oil

OELANALYSE SET 3 - Oil analysis set for bio oil

OELANALYSE SET 4 - Oil analysis set for gear oil

HK FES SUP

Fluid sampling set, static

The fluid sampling set is used for safely collecting fluids from containers and systems

The fluid is sucked through the 1000 mm long hose and directly into the glass sample bottle by the vacuum pump.

Application: General hydraulic systems

Scope of supply: 1 x vacuum pump, 3 x 250 ml sample bottles, glass, 2 x 500 ml sample bottles, glass, 2 x 500 ml sample bottles, plastic, 1 x adapter for sample bottles, 2 x PVC hoses, 1 x pipe section



Identification	Weight kg
HK FES-SUP	1,45

Web: <http://cat.hansa-flex.com/en/HKFESSUP>

Spare parts:

HK PROBEF LDPE - Plastic sample bottle

HK PROBEF GL - Glass sample bottle

HK PROBEF ADA AL - Adapter for sample bottle

HK VAK PUMPE - Vacuum hand pump

HK VAK PUMPE

Vacuum hand pump



Vacuum hand pump for fluid collection.
Fits HK FES SUP and HK VAK FILTRA-GL.

Connection: Hose fitting = 6 mm diameter

Identification	Weight kg
HK VAK-PUMPE	0,37

Web: <http://cat.hansa-flex.com/en/HKVAKPUMPE>

Spare part for following products:

HK FES SUP - Fluid sampling set, static

Accessory for following products:

HK VAK FILTRA GL - Glass vacuum filtration device

HK PROBEF LDPE

Plastic sample bottle



Plastic sample bottle for fluid sampling set.

Scope of supply: Sample body, Version "MD": Sample bottle with cap

Identification	Weight kg	Content mL	Material	Colour
HK PROBEF-LDPE500	0,05	500	Plastic	white, transparent
HK PROBEF-LDPE500 MD	0,07	500	Plastic	white, transparent

Web: <http://cat.hansa-flex.com/en/HKPROBEFLDPE>

Accessories:

HK PROBEF LDPE DEK - Cover for plastic sample bottle

HK PROBEF LDPE DEK

Cover for plastic sample bottle



Sealing cap for sample bottle of plastic.

Identification	Weight kg	Material	Colour
HK PROBEF-LDPE-DEK	0,02	Plastic	white, transparent

Web: <http://cat.hansa-flex.com/en/HKPROBEFLDPEDEK>

Accessory for following products:

HK PROBEF LDPE - Plastic sample bottle

HK PROBEF GL**Glass sample bottle**

Glass sample bottle for fluid sampling set.

Scope of supply: Sample body, Version "MD": Sample bottle with cap



Identification	Weight kg	Content mL	Material
HK PROBEF-GL250	0,24	250	Glass
HK PROBEF-GL250 MD	0,25	250	Glass
HK PROBEF-GL500	0,36	500	Glass
HK PROBEF-GL500 MD	0,37	500	Glass

Web: <http://cat.hansa-flex.com/en/HKPROBEFGL>

Accessories:

HK PROBEF GL DEK - Cover for glass sample bottle

HK PROBEF ADA AL - Adapter for sample bottle

HK PROBEF GL DEK**Cover for glass sample bottle**

Sealing cap for sample bottle of glass.



Identification	Weight kg	Material	Colour
HK PROBEF-GL-DEK	0,01	Plastic	black

Web: <http://cat.hansa-flex.com/en/HKPROBEFGLDEK>

Accessory for following products:

HK PROBEF GL - Glass sample bottle

HK PROBEF ADA AL**Adapter for sample bottle**

Cover with 2 hose connections for extracting the fluid.

Note: Only suitable for glass sample bottles.

Identification	Weight kg	Material
HK PROBEF-ADA-AL	0,33	Aluminium

Web: <http://cat.hansa-flex.com/en/HKPROBEFADAAL>

Spare part for following products:

HK FES SUP - Fluid sampling set, static

Accessory for following products:

HK PROBEF GL - Glass sample bottle

HK VAK PUMPE - Vacuum hand pump

HK PART

Particle counter

The HKPART-Z particle counter serves as a mobile service for temporary measurement of solid contaminants in hydraulic systems, e.g., in control circuits, pressure circuits, and unpressurised containers.

With the integrated Aqua-Sensor, the equipment is also able to measure moisture and temperature.

The data collected can be transmitted to a PC via Bluetooth, and analysed there using the software supplied with the equipment.

Application: Service in mobile hydraulics, Servicing hydraulic machines

Scope of supply: HKPART-Z particle counter, Mains adapter with mains connection cable, High-pressure adapter (pressure limiter) for pressurised lines, Pressure hose with screw connection for M16 x 2 measuring coupling, length = 2 m, Suction hose with screw connection, transparent, length = 0.3 m, Return hose with plug-in connection, open end, transparent, length = 1 m, USB Bluetooth dongle, Software, Operating and maintenance manual / Calibration certificate

Additional feature: Suitable for hydraulic oils having a viscosity up to 350 mm²/s, Purity classes conforming to ISO and SAE or NAS, Integrated AquaSensor for measuring moisture and temperature

Note: When used in systems with a pressure above 45 bar, the high pressure adapter (P_{max} = 345 bar) must be used.

Work on hydraulic systems must only be carried out by technically qualified personnel and compliance with the safety regulations in force.

The operating manual for this equipment must be followed to prevent injury to personnel and damage to the environment!



Identification	Max. working pressure bar	Weight kg
HK PART-Z	45	13

Web: <http://cat.hansa-flex.com/en/HKPART>

HK ICM

Inline Contamination Monitor



Optical particle sensor with LED-counter
 for mounting in pressure line or return line
 8-channel contamination measurement
 & display
 Measures and displays according ISO 4406:1999, NAS 1638, AS 4059E and ISO 11218
 Data logging and 4000 test result memory
 Measuring accuracy: $\pm 1/2$ code for 4,6,14 $\mu\text{m(c)}$; ± 1 code for larger particles;
 $\pm 3\%$ for moisture and temperature
 Test time adjustable 10 - 3600 sec. (factory setting 120 sec.), free programmable test intervals
 Previous ten result viewing capability
 Power supply by USB-interface HK ICM USB I
 Version R with Multicolour LED and remote alarm signaling
 Robust die-cast aluminium housing
 Protection class IP 65

Application: for direct mounting in systems and applications, for ongoing measurement also in limited space applications

Scope of supply: with LPA-View software

Operating voltage: 9 - 36 V DC

Operating temperature: -25 °C bis +80 °C

Flow rate: 20 - 400 ml/min

Power input: max. 2,2 W

Additional feature: Suitable for hydraulic oils having a viscosity up to 1000 mm²/s, Purity classes conforming to ISO and SAE or NAS, Integrated AquaSensor for measuring moisture and temperature

Identification	Connections	Max. working pressure bar	Weight kg
HK ICM WMKR G1	Minimes M16x2	400	1,2

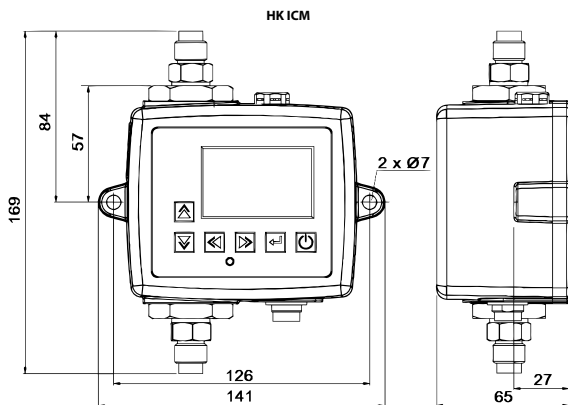

Web: <http://cat.hansa-flex.com/en/HKICM>

Accessories:

HK ICM USB - USB adapter

HK ICM USB**USB adapter**

allows power supply and control function (connected to computer) for contamination monitor HK ICM WMKR G1

Application: USB-interface for contamination monitor

Scope of supply: with power supply unit and wire 3m

Use: For particle sensor HK ICM



Identification	Weight kg
HK ICM USB I	0,5

Web: <http://cat.hansa-flex.com/en/HKICMUSB>

Accessory for following products:

HK ICM - Inline Contamination Monitor

HK VAK FILTRA GL**Glass vacuum filtration device**

Glass vacuum filtration device for visual evaluation of liquids.

Connection: Hose fitting = 6 mm diameter



Note: Highly viscous media should be diluted with a technical solution (e.g. NHEPTAN-TECH).

Ordering information: Diaphragm filters, vacuum pump and extraction hose must be ordered separately.

Identification	Weight kg
HK VAK-FILTRA-GL	1,7

Web: <http://cat.hansa-flex.com/en/HKVAKFILTRAGL>

Additional info: The oil sample is drawn through the filter and into the filter bottle with the aid of a vacuum pump. The residue in the filter provides a preliminary indication of the degree of contamination of the oil. The filtrate bottle can hold up to 1000 ml, the glass top can hold up to 250 ml, the filtration area is 12.5 cm² with a filter diameter of 50 mm.

Accessories:

HK VAK MEM - Filter for vacuum filtration

Additional elements:

HK VAK PUMPE - Vacuum hand pump

OELANALYSE SET 2

Oil analysis set for mineral oil



With the oil analysis set, the condition of an oil can be analysed precisely in the lab. The condition of the system can also be deduced from the result of the oil analysis.

Scope of supply: 1 x sample container, 1x Sample data sheet, 1x shipping case

Additional feature: Analysis costs are included in the price., All oil samples will be evaluated within 24 hours of receipt at the laboratory.

Identification	Colour	for medium	Weight kg
OEL ANALYSE SET 2	black cover	Mineral oil-based hydraulic oil	0,2

Web: <http://cat.hansa-flex.com/en/OELANALYSESET2>

Additional info: The oil analysis set 2 includes the following analyses:

- Wearing metals (iron, chrome, tin, aluminium, nickel, copper, lead, molybdenum),
- PQ index (magnetisable iron parts),
- Additives (calcium, magnesium, zinc, phosphorus, barium, boron),
- Contaminants (silicon, potassium, sodium, water as %),
- Oil condition (viscosity at +40° and +100°C),
- Viscosity index,
- Oxidation,
- Appearance of the oil,
- Particle count according to ISO 4406, SAE 4059.

OELANALYSE SET 3

Oil analysis set for bio oil



With the oil analysis set, the condition of an oil can be analysed precisely in the lab. The condition of the system can also be deduced from the result of the oil analysis.

Scope of supply: 1 x sample container, 1x Sample data sheet, 1x shipping case

Additional feature: Analysis costs are included in the price., All oil samples will be evaluated within 24 hours of receipt at the laboratory.

Identification	Colour	for medium	Weight kg
OEL ANALYSE SET 3	yellow cover	Biologically degradable hydraulic fluids	0,2

Web: <http://cat.hansa-flex.com/en/OELANALYSESET3>

Additional info: The oil analysis set 3 includes the following analyses:

- Wearing metals (iron, chrome, tin, aluminium, nickel, copper, lead, molybdenum),
- PQ index (magnetisable iron parts),
- Additives (calcium, magnesium, zinc, phosphorus, barium, boron),
- Contaminants (silicon, potassium, sodium, water as %),
- KF water,
- Oil condition (viscosity at +40° and +100°C),
- Viscosity index,
- Oxidation,
- Neutralisation value,
- Appearance of the oil,
- Colour number,
- Density,
- Particle count according to ISO 4406, SAE 4059.

OELANALYSE SET 4**Oil analysis set for gear oil**

With the oil analysis set, the condition of an oil can be analysed precisely in the lab.
The condition of the system can also be deduced from the result of the oil analysis.

Scope of supply: 1 x sample container, 1x Sample data sheet, 1x shipping case

Additional feature: Analysis costs are included in the price., All oil samples will be evaluated within 24 hours of receipt at the laboratory.



Identification	Colour	for medium	Weight kg
OEL ANALYSE SET 4	red cover	Gearbox oil	0,2

Web: <http://cat.hansa-flex.com/en/OELANALYSESET4>

Additional info: The oil analysis set 4 includes the following analyses:

- Wearing metals (iron, chrome, tin, aluminium, nickel, copper, lead, molybdenum),
- PQ index (magnetisable iron parts),
- Additives (calcium, magnesium, zinc, phosphorus, barium, boron),
- Contaminants (silicon, potassium, sodium, water as %),
- KF water,
- Oil condition (viscosity at +40° and +100°C),
- Viscosity index,
- Oxidation,
- Neutralisation value,
- Appearance of the oil,
- O.P.A. with particle count

HK VAK MEM**Filter for vacuum filtration**

The white cellulose nitrate filter is printed with a black mesh pattern.
Each filter is packaged separately and under sterile conditions.



Ordering information: Other filter units are available upon request.

Identification	Diameter mm	Filter mesh size µm	Packaging unit	Weight kg
HK VAK-MEM-FILTER	50	0,8	100 piece	0,14

Web: <http://cat.hansa-flex.com/en/HKVAKMEM>

Spare part for following products:

HK VAK FILTRA GL - Glass vacuum filtration device

NSFA Typ C

Bypass flow filter system Type C



Partial flow filter systems increase the reliability and operational readiness of many hydraulic and lubricating oil systems. Oil filtering prolongs the service life not only of the machine, but also of the entire system. When a partial flow system is used, the filter can work permanently without being affected by changes in pressure or volume flow in the main system.

The equipment is particularly notable for its compact construction and low noise level.

Media: Mineral oil, Synthetic oils, turbine oils, vegetable oils

Ordering information: All filter systems are supplied without filter elements.
Other volume flows and motor outputs available upon request.

Identification	Voltage	Power kW	Volumetric flow max. L/min	System size*	Weight kg
NSFA TYP C 80/380 V 3.0	380 V	3,0	80,0	up to 2500 litres	45

System size serves only a reference value

Web: <http://cat.hansa-flex.com/en/NSFATYPC>

Additional info: Double filter system, 2 filter elements are needed. The filter systems can be rented by the day, the week, or by the month.

Our service technicians will then install and commission the equipment for a fee.

Duration of filtration depends essentially on the degree of contamination of the medium.

Accessories:

FI ND E UF - Filter element for low-pressure filter UF

NSFA Typ D

Bypass flow filter system Type D



Partial flow filter systems increase the reliability and operational readiness of many hydraulic and lubricating oil systems. Oil filtering prolongs the service life not only of the machine, but also of the entire system. When a partial flow system is used, the filter can work permanently without being affected by changes in pressure or volume flow in the main system.

The equipment is particularly notable for its compact construction and low noise level.

Media: Mineral oil, Synthetic oils, turbine oils, vegetable oils

Ordering information: All filter systems are supplied without filter elements.
Other volume flows and motor outputs available upon request.

Identification	Voltage	Power kW	Volumetric flow max. L/min	System size*	Weight kg
NSFA TYP D 40/24 V 035	24 V	0,35	40,0	up to 1200 litres	15
NSFA TYP D 40/230 V 1.5	230 V	1,50	40,0	up to 1200 litres	18
NSFA TYP D 10/380 V 055	380 V	0,55	10,0	up to 1000 litres	20
NSFA TYP D 40/380 V 1.5	380 V	1,50	40,0	up to 1200 litres	23
NSFA TYP D 60/380 V 1.5	380 V	1,50	60,0	up to 1200 litres	23

System size serves only a reference value

Web: <http://cat.hansa-flex.com/en/NSFATYPD>

Additional info: The filter systems can be rented by the day, the week, or by the month.

Our service technicians will then install and commission the equipment for a fee.

Duration of filtration depends essentially on the degree of contamination of the medium.

Accessories:

FI ND E MA - Filter element for low-pressure filter MA

NSFA Typ E

Bypass flow filter system Type E

Partial flow filter systems increase the reliability and operational readiness of many hydraulic and lubricating oil systems. Oil filtering prolongs the service life not only of the machine, but also of the entire system. When a partial flow system is used, the filter can work permanently without being affected by changes in pressure or volume flow in the main system.

The equipment is particularly notable for its compact construction and low noise level.

Media: Mineral oil, Synthetic oils, turbine oils, vegetable oils



Ordering information: All filter systems are supplied without filter elements.
Other volume flows and motor outputs available upon request.

Identification	Voltage	Power kW	Volumetric flow max. L/min	System size*	Weight kg
NSFA TYP E 150/380 V 55	380 V	5,5	150,0	above 2500 litres	175
System size serves only a reference value					

Web: <http://cat.hansa-flex.com/en/NSFATYPE>

Additional info: The filter systems can be rented by the day, the week, or by the month.
Our service technicians will then install and commission the equipment for a fee.
Duration of filtration depends essentially on the degree of contamination of the medium.

Accessories:

FI ND E MA - Filter element for low-pressure filter MA

HK FAPC

Oil service appliance

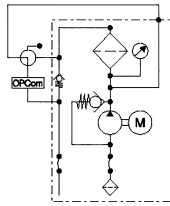

With the filter unit, hydraulic or lubricating oil systems can simply be filled and cleaned in the bypass flow. The unit is suitable for use with mineral oils and eco-friendly hydraulic fluids. The compact design allows easy access to the oil tank. The HK FAPC 016 is equipped with hoses and ready to connect. The superfine filter elements can be replaced without any special tools required. The suction and pressure hoses are coiled up directly on the device. Remaining oil droplets are collected in the oil drip tray. The heart of the filtration appliance are the EXAPOR® superfine filter elements. High separation rates guarantee very high degrees of cleanliness, and hence maximum component protection. The high soiling absorption capacity of the EXAPOR® ultrafine filter elements permit cost-effective operation of the unit. A pressure gauge indicates when the filter element has to be replaced. The water-absorbing filter element EXAPOR® Aqua can be installed briefly to remove small amounts of water from hydraulic oils - available on request - The HK FAPC 016 is equipped with a purity class monitor OPCOMII. The purity class achieved during the filling or cleaning process is continuously monitored. When monitoring the purity level a ball cock can be used to select between "downstream of filter" (e.g. when filling systems) or "upstream of filter" (e.g. cleansing oil fillings). Selection between particle sizes 4, 6, 14 and 21 µm can be made on the display. The reference number for the selected particle size according to ISO 4406:1999 is displayed on the monitor. The monitor can be configured by PC using the infrared interface. The data can be transferred to the computer via the RS232 interface, where it can be displayed graphically or in tabular form and tracked.

Note: Length of suction/pressure hose 1.8 / 2.0 m
The device is equipped with a data memory (storage of 500 purity classes with date and time; download in Excel-compatible format).

Identification	Nominal volume current L/min	Soiling capacity g	Viscosity mm2/s max.	Electric motor	for filter type	Suction height max. m	BD max. bar	Weight kg
HK FAPC 016 2105 BD = Working pressure	16	280	150	230V/50Hz0,45kW	3E-NB(c)=200	1,5	4	24

Web: <http://cat.hansa-flex.com/en/HKFAPC>

- Spare parts:**
 HK FAPC F - Filter element for oil service appliance HK FAPC 016
Accessories:
 HK FAPC 1760 - Unit carrier

HK FAPC 1760**Unit carrier**

For simplified transportation of the HKFAPC016 the trolley can be attached to the stationary appliance.

Easy transportation is thus possible, even over longer distances.

Use: For oil service appliance HK FAPC 016



Identification	Weight kg
HK FAPC 016 1760	3

Web: <http://cat.hansa-flex.com/en/HKFAPC1760>

Accessory for following products:

HK FAPC - Oil service appliance

HK FAPC F**Filter element for oil service appliance HK FAPC 016**

Identification	Filter mesh size μm	for filter type	Weight kg
HK FAPC V71220 113	3	3E-N; $\beta(c)=200$	1,2

Web: <http://cat.hansa-flex.com/en/HKFAPCF>

Spare part for following products:

HK FAPC - Oil service appliance

OEL HLP

Mineral oil-based hydraulic oil



Hydraulic oil based on mineral oil with agents against corrosion, oil ageing and wear.

- Application:** as universal oil, e.g. hydraulic presses, injection moulding machines, construction machinery etc.
Classification: HLP
Standard: DIN 51524-2

Note: Note: Do not mix different oils.

Identification	Viscosity class	Packaging unit
OEL HLP 32	ISO VG 32	20 litres
OEL HLP 46	ISO VG 46	20 litres

Web: <http://cat.hansa-flex.com/en/OELHLP>

OEL HLPD 46

Mineral oil-based hydraulic oil



Detergent hydraulic oil based on mineral oil containing agents against corrosion, oil ageing and wear.

- Application:** as universal oil, e.g. hydraulic presses, injection moulding machines, construction machinery etc.
Classification: HLPD
Additional feature: Especially suitable for systems with sensitive control valves.

Note: Note: Do not mix different oils.

Identification	Viscosity class	Packaging unit
OEL HLPD 46	ISO VG 46	20 litres

Web: <http://cat.hansa-flex.com/en/OELHLPD46>

Additional info: The detergent properties remove deposits from the hydraulics and prevent adhesion. HLPD oils demonstrate a unique property of absorbing certain amounts of water without causing operating problems in the hydraulic system.

OEL PANOLIN

Hydraulic oil, synthetic (Panolin)



Environmentally compatible, fully synthetic and zinc-free hydraulic oil based on saturated esters. Very good high pressure properties with excellent cold flow behaviour and good oxidation behaviour during long periods of use.

- Application:** Forestry-, construction- and agricultural machines, Steel hydraulics construction, Circular lubrication systems
Classification: HEES
Standard: DIN ISO 15380

Note: Note: Do not mix different oils.

Identification	Viscosity class	Packaging unit
OEL PANOLIN	ISO VG 46	25 litres

Web: <http://cat.hansa-flex.com/en/OELPANOLIN>

OEL SYNT

Synthetic ester-based hydraulic oil

Zinc- and ash-free hydraulic oil. Particularly suitable for use in ecologically sensitive areas.

Application: e.g. mobile hydraulics

Classification: HEES

Standard: DIN ISO 15380



Note: Note: Do not mix different oils.

Identification	Viscosity class	Packaging unit
OEL SYNT	ISO VG 46	20 litres

Web: <http://cat.hansa-flex.com/en/OELSYNT>

2

OEL W

Mineral oil-based engine oil

Application: for petrol and diesel engines (Note releases of the manufacturer!)



Note: Note: Do not mix different oils.

Identification	Area	Packaging unit
OEL 10 W	Monograde oil	20 litres
OEL 10 W 40	Multigrade oil	20 litres

Web: <http://cat.hansa-flex.com/en/OELW>

OEL ATF

Transmission and hydraulic oil

Application: Forestry-, construction- and agricultural machines, Gear boxes and self-lubricating differentials



Note: Note: Do not mix different oils.

Identification	Specification	Packaging unit
OEL ATF		20 litres
OEL ATF 66	Suffix A	20 litres
OEL ATF 86	Dexron II	20 litres

Web: <http://cat.hansa-flex.com/en/OELATF>

OEL MATTE**Oil binding agent, (matt)**

Oil binder for receiving oil-based non-woven fabrics from polypropylene homopolymer (PP)

Additional feature: 1 pack = 10 pieces

Identification

OEL MATTE

Dimension

43 x 33 cm

Web: <http://cat.hansa-flex.com/en/OELMATTE>

OEL BIND**Oil binding agent, (granular)**

Material: Calcined diatomaceous earth (Moler), no chemical and synthetic additives.
Oil binder, Type III R

Note: Insoluble in water and acids.

Identification

OEL BIND

Weight

kg

15

Web: <http://cat.hansa-flex.com/en/OELBIND>

Additional info: No risk to persons, animals, plants and ground water. 1 litre oil binder, coarse grain, 1 - 3 mm binds approx. 0.4 litres of oil.



Measuring equipment

Volumetric flow meters

Analogue volume flow meters	458
-----------------------------	-----

Digital measurement technology

5-channel gauge	459
2-channel gauge	463

Gear flow meter

Gear flow meter VCA, SD	465
-------------------------	-----

Flow switch

Flow switch BFS	466
-----------------	-----

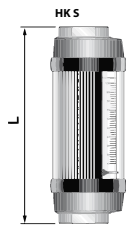
HK S
Analogue Q gauge

Independent of position, direct reading, one flow direction.
 Linear gauge scale in l/min.
 Sturdy and resistant to shock and vibration.
 Accuracy $\pm 2\%$ of range limit value.

Application: Volumetric flow measurement
Operating temperature max.: 120 °C
Material: Stainless steel housing

Identification	Thread	Measuring range	Pressure max. bar	L mm	Weight kg
HK 602 S 005	G 1/2"	2 to 20 l/min	420	168	0,90
HK 602 S 010	G 1/2"	4 to 37 l/min	420	168	0,90
HK 602 S 015	G 1/2"	5 to 55 l/min	420	168	0,90
HK 702 S 020	G 3/4"	10 to 75 l/min	350	183	1,75
HK 702 S 030	G 3/4"	10 to 115 l/min	350	183	1,75
HK 762 S 040	G 1"	10 to 150 l/min	350	183	1,75
HK 762 S 050	G 1"	20 to 190 l/min	350	183	1,75
HK 802 S 075	G 1.1/4"	40 to 280 l/min	350	310	8,00
HK 802 S 100	G 1.1/4"	50 to 370 l/min	350	310	8,00
HK 802 S 150	G 1.1/4"	50 to 560 l/min	350	310	8,00

Web: <http://cat.hansa-flex.com/en/HKS>

HK S TK
Analogue QPT gauge

Independent of position, direct reading, one flow direction.
 Linear gauge scale in l/min.
 Sturdy and resistant to shock and vibration.
 Accuracy $\pm 2\%$ of range limit value.

Application: Volumetric flow measurement
Design: with thermometer up to 120 °C and pressure gauge coupling M16 x 2 with pressure gauge
Operating temperature max.: 120 °C
Material: Stainless steel housing

Identification	Thread	Measuring range	Pressure max. bar	L mm	Weight kg
HK 702 S 020 TK	G 3/4"	10 to 75 l/min	350	226	1,9
HK 702 S 030 TK	G 3/4"	10 to 115 l/min	350	226	1,9
HK 762 S 040 TK	G 1"	15 to 150 l/min	350	226	1,9
HK 762 S 050 TK	G 1"	19 to 190 l/min	350	226	1,9

Web: <http://cat.hansa-flex.com/en/HKSTK>

HK S TKV

Analogue QPT-K gauge

Independent of position, direct reading, one flow direction.
 Linear gauge scale in l/min.
 Sturdy and resistant to shock and vibration.
 Accuracy $\pm 2\%$ of range limit value
 Ideal for service tests on hydraulic pumps, units and drives in mobile and stationary hydraulics
 Overload protection is integrated into the pressurising valve for device protection, overload rupture (without oil leakage) at 420 bar

Application: Volumetric flow measurement
Design: with thermometer up to 120 °C and pressure gauge coupling M16 x 2 with pressure gauge, with pressurising valve, internal overload protection and protective case

Operating temperature max.: 120 °C

Material: Stainless steel housing



Identification	Connection	Measuring range	Pressure max. bar	L mm	Weight kg
HK 702 S 020 TKV	G 3/4"	10 to 75 l/min	350	303	7,4
HK 702 S 030 TKV	G 3/4"	10 to 115 l/min	350	303	7,4
HK 762 S 040 TKV	G 1"	15 to 150 l/min	350	303	7,9
HK 762 S 050 TKV	G 1"	19 to 190 l/min	350	303	7,9

Web: <http://cat.hansa-flex.com/en/HKSTKV>

HK PTQ CHECK

Digital hand-held gauge, 5-channels

5-channel gauge for simultaneous measurement of pressure, differential pressure, volumetric flow and temperature.

Simultaneous connection of max. 4 sensors (2x pressure, 1x temperature, 1x volumetric flow).

A speed sensor can be connected in place of the volumetric flow sensor.

Graphic display with background lighting.

Oil-resistant film keypad.

Convenient menu navigation, different languages and unit systems can be selected.

Data interface RS 232 / USB adapter.

Sensor detection, self-diagnostics and battery check integrated.

Automatic zero-point correction.

Min/max storage (no storage of complete measurement sequence).

Average value memory of 10sec or 20sec.

Design: for pressure, differential pressure, temperature, volumetric flow and speed, 50/sec measurement rate

Scope of supply: incl. PC connection cable and software, incl. power supply 230 V / 50 Hz

Note: For storing the measurement sequence during measuring the appliance must be connected to a PC on which the enclosed software has been installed

Ordering information: This gauge can be combined with the included accessories to a measuring case.

1 gauge, 1 measuring turbine and various sensors incl. cable and operating manual can be packed into the HK KS33 case.

Further accessories and gauges with additional options available on request.



Identification	Weight kg
HK PTQ CHECK5	0,5

Web: <http://cat.hansa-flex.com/en/HKPTQCHECK>

Accessories:

HK 622 - Measuring turbine

HK PTA - Pressure sensor

HK TS TP - Temperature sensor

HK DS 100 - Speed sensor

HK PML - Single instrumentation cable

HK PQT - Combination instrumentation cable

HK KS33 - Protective case for measuring instrument

HK 622

Measuring turbine

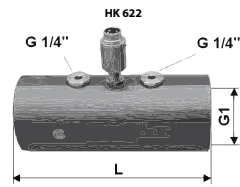

Independent of position, one measuring direction
 Various measuring ranges up to 600 l/min
 Measuring accuracy $\pm 2\%$ of range limit value
 Output signal: Frequency

Connections: 1/4 - female thread"
Design: with connections for volumetric flow, pressure and temperature

Temp. min.: 0 °C

Temp. max.: 90 °C

Material: Aluminium housing

Surface: anodised

Use: For gauge HK PTQCheck

Ordering information: Further accessories and gauges with additional options available on request.

Identification	Measuring range	Pressure max. bar	Overload pressure max. bar	G1	L mm	Weight kg
HK 6222 025	1 to 25 l/min	400	420	G 1/4"	120	0,45
HK 6226 300	15 to 300 l/min	400	420	G 1.1/4"	150	0,90
HK 6228 600	40 to 600 l/min	400	420	G 1.1/2"	173	1,70

Web: <http://cat.hansa-flex.com/en/HK622>

Accessory for following products:

HK PTQ CHECK - Digital hand-held gauge, 5-channels

Additional elements:

HK PQT - Combination instrumentation cable

HK PML - Single instrumentation cable

HK PTA

Pressure sensor

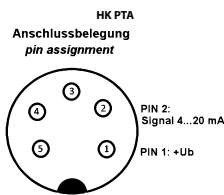

Resistant to pressure peaks, extremely shock and vibration-resistant
 Output signal 4 to 20 mA

Various measuring ranges up to 600 bar

Measuring accuracy $\pm 0.5\%$ of range limit value

Outer thread 1/4" fitting

Connections: 1/4" - male thread

Material: Stainless steel

Use: For gauge HK PTQCheck

Ordering information: Further accessories and gauges with additional options available on request.

Order adapter HFM MMD 1/4 (when connecting pressure transmitter and measuring turbine) separately

Identification	Measuring range	Pressure max. bar	Overload pressure max. bar	Connection	Weight kg
HK PTA 101	-1 to 10 bar	10	20	G 1/4" - male thread	0,1
HK PTA 060	0 to 60 bar	60	120	G 1/4" - male thread	0,1
HK PTA 200	0 to 200 bar	200	400	G 1/4" - male thread	0,1
HK PTA 400	0 to 400 bar	400	600	G 1/4" - male thread	0,1
HK PTA 600	0 to 600 bar	600	800	G 1/4" - male thread	0,1

Web: <http://cat.hansa-flex.com/en/HKPTA>

Accessory for following products:

HK PTQ CHECK - Digital hand-held gauge, 5-channels

Additional elements:

HK PML - Single instrumentation cable

HK PQT - Combination instrumentation cable

HFM MMD HKO - Measuring connection, M16 x 2 series

HK TS TP
Temperature sensor

Measurement range -50 °C to +120 °C

Measuring accuracy ± 0.2 °C

Outer thread 1/4" fitting

Output signal 4 to 20 mA

Material: Stainless steel

Use: For gauge HK PTQCheck



Ordering information: Further accessories and gauges with additional options available on request.

Identification	Measuring range	Pressure max. bar	Overload pressure max. bar	Connection	Weight kg
HK TS TP 140	-50 to +120 °C	400	420	G 1/4" - male thread	0,1

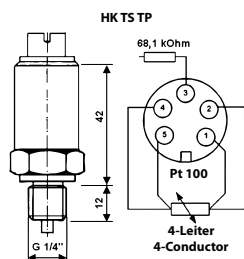

Web: <http://cat.hansa-flex.com/en/HKTSTP>

Accessory for following products:

HK PTQ CHECK - Digital hand-held gauge, 5-channels

Additional elements:

HK PML - Single instrumentation cable

HK PQT - Combination instrumentation cable

HK DS 100
Speed sensor

Speed sensor, opto-electronic

Incl. 5 m measuring lead and 25 reflective markers

Use: For gauge HK PTQCheck

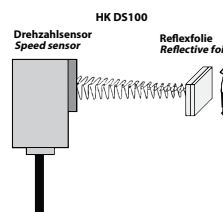

Ordering information: Further accessories and gauges with additional options available on request.

Identification	Measuring range	Weight kg
HK DS 100	500 to 9999 rpm	0,18

Web: <http://cat.hansa-flex.com/en/HKDS100>

Accessory for following products:

HK PTQ CHECK - Digital hand-held gauge, 5-channels

HK PML

Single instrumentation cable



Design: for connecting one pressure sensor, Plug M12 5-pin
Use: For gauge HK PTQCheck

Ordering information: Further accessories and gauges with additional options available on request.

Identification	Length mm	Weight kg
HK PML 03 SS	3000	0,1

Web: <http://cat.hansa-flex.com/en/HKPML>

Accessory for following products:
 HK PTQ CHECK - Digital hand-held gauge, 5-channels

HK PQT

Combination instrumentation cable



Practical spiral cable for easy handling
 Length 3 m
Design: Combination cable for pressure, volumetric flow and temperature sensor, Plug M12 5-pin
Use: For gauge HK PTQCheck

Ordering information: Further accessories and gauges with additional options available on request.

Identification	Length mm	Weight kg
HK PQT 03 SS	3000	0,2

Web: <http://cat.hansa-flex.com/en/HKPQT>

Accessory for following products:
 HK PTQ CHECK - Digital hand-held gauge, 5-channels

HFM MMD HKO

Measuring connection, M16 x 2 series

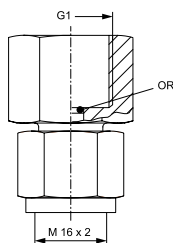

Connection 1: BSP cylindrical internal threads
Sealing form 1: O-ring seal
Connection 2: Metric nut thread M 16 x 2
Design: Direct pressure gauge connection
Scope of supply: with O-ring
Temp. min.: -20 °C
Temp. max.: 100 °C
Material: Steel
Surface: electro galvanised

Note: When assembling with HK PTA sensor, remove the existing O-ring in the fitting if available.

Identification	Max. working pressure bar	OR	G1
HFM MMD 1/4	630	5.0 x 1.5	G 1/4" -19

Web: <http://cat.hansa-flex.com/en/HFMMMDHKO>

Accessory for following products:
 HK PTA - Pressure sensor

HK KS33

Protective case for measuring instrument

Plastic with padding

For protected transport of 1 gauge with PSU, 1 measuring turbine, various sensors and cables

Use: For gauge HK PTQCheck



Ordering information: Further accessories and gauges with additional options available on request.

Identification	Weight kg
HK KS 3300	1,7

Web: <http://cat.hansa-flex.com/en/HKKS33>

Accessory for following products:

HK PTQ CHECK - Digital hand-held gauge, 5-channels

HK MH 2025

Digital gauge set

Compact measuring device
 Direct handling by 5 softkeys
 2 channels for industrial sensors (optional 0-20 mA, 4-20 mA, 0-10 V, 2-10 V, frequency, counter)
 Calculation of differential pressure or power from 2 channels
 ISDS automatic sensor detection
 LCD graphic display with switched-mode backlight and automatic display adjustment
 2,0 MB memory (5 series of measurements with 120,000 measured values)
 Scanning rate selectable in 5 stages between 1 ms and 10 s
 Display rate selectable between 0,5 ms and 10 ms
 High-speed data transmission to the PC via USB interface
 With software HYDROlink Base
 Lightweight plastic housing with battery compartment for commercially available NiMH rechargeable batteries
 Case dimensions: W=235 mm / L=185 mm / H=48 mm

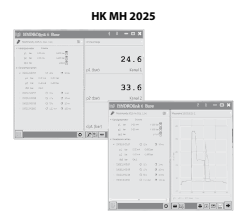

Scope of supply: 1 measuring device HK MH 2025, 1 USB-power supply unit 5 VDC, 500 mA, 2 NiMH rechargeable batteries, 2 pressure sensors with moulded cable (length 2.5 m), pressure ranges, see table, 2 MINIMESS® direct connectors for pressure sensors, Software, Operating manual, Plastic case

Temp. range: -20 °C to +70 °C

Identification	Pressure sensors included	Weight kg
HK MH2025 400 400	2x 0 - 400 bar	3,5
HK MH2025 060 600	1x 0 - 60 bar/1x 0 - 600 bar	3,5

Web: <http://cat.hansa-flex.com/en/HKMH2025>

Accessories:

HK PT2020 - Pressure sensor

HK PT2020**Pressure sensor**

Signal output 0-20 mA
 Accuracy $\pm 0.5\%$ of range limit value
 Max. pressure = 1.5x nominal pressure
 Medium temperature -40°C to +130°C
 ISDS automatic sensor detection
 Incl. moulded cable 2.5 m

Material: of stainless steel
Use: Only for gauge set MH 2025

Note: Attention: These sensors are only suitable for gauge HK MH 2025!

Identification	Measuring range	Weight kg
HK PT2020 006	-1 to 6 bar	0,12
HK PT2020 060	0 to 60 bar	0,12
HK PT2020 200	0 to 200 bar	0,12
HK PT2020 400	0 to 400 bar	0,12
HK PT2020 600	0 to 600 bar	0,12

Web: <http://cat.hansa-flex.com/en/HKPT2020>

HK VCA
Gear flow meter

Series HK VCA gear flow meters are flow meters for viscous fluids. The metering system consists of a pair of gears, which are driven by the flow of fluid using the same principle as a gear motor.

The metering system bearings are designed as radial-axial friction bearings. The motion of the gears is sampled by a magnetoresistive sensor separate from the metering room.

Measuring accuracy HK VCA 2: $\pm 2.5\%$ of range limit value

Measuring accuracy HK VCA 5: $\pm 1.0\%$ of range limit value

Protection class IP 64 DIN 40050

1 measuring channel

Pulse amplitude: $U_A \geq 0.8 U_B$

Output signal pulse shape: Rectangular, scanning ratio/channel 1:1 $\pm 15\%$

Application: Volumetric flow measurement

Output signal: PNP / NPN

Operating voltage: 12 - 30 V DC, polarised

Operating temperature max.: 80 °C

Material: Housing: Aluminium AlMgSi F30, Measurement mechanism: Steel 1.7139

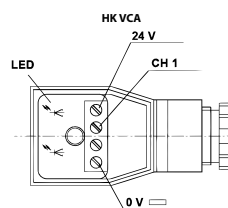

Identification	Design	Thread	Measuring range	Pressure max. bar	Weight kg
HK VCA 2 FC R1	Square wave output signal	G 3/4"	1 to 65 l/min	160	1,9
HK VCA 2 FC R1V	without preamplifier (for plug-in display HK SD1)	G 3/4"	1 to 65 l/min	160	1,8
HK VCA 5 FE R1 176	Square wave output signal	G 1"	1 to 200 l/min	80	6,0
HK VCA 5 FE R1V 176	without preamplifier (for plug-in display HK SD1)	G 1"	1 to 200 l/min	80	6,0

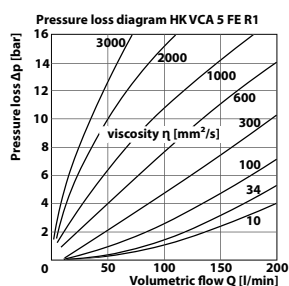
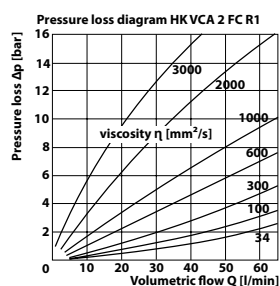
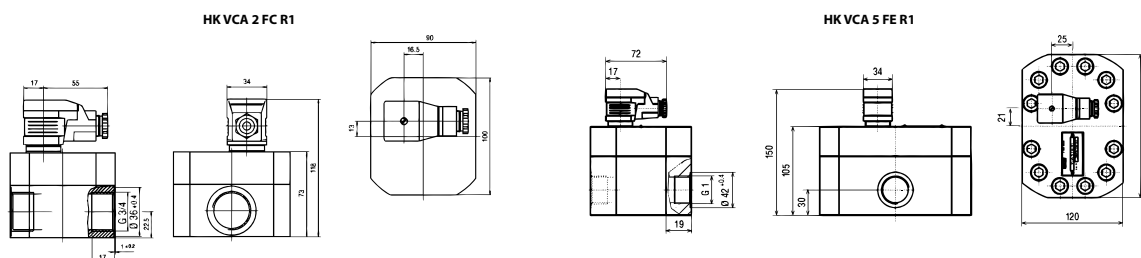

Web: <http://cat.hansa-flex.com/en/HKVCA>

Accessories:

HK SD1 - Plug-in display digital

HK SD1

Plug-in display digital

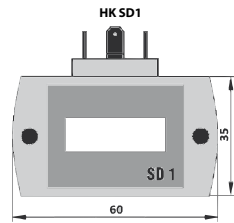

The on-site display for the gear flow meter HK VCA with plug-in connection in accordance with DIN 43650 is usable in the widest possible range of applications. The display is simply inserted between the plug and socket of the flow meter. As with standard meters, square wave signal output is available to allow external processing.

The plug-in display is freely programmable. All the necessary settings can be made using two buttons. The programmed data are stored on an EEPROM and are therefore permanently retained, even in the event of power outages.

Display: 7-segment LED

Keypad: 2 keys behind front panel

Supply voltage: 24 VDC

Protection class IP 64 DIN 40050

Operating temperature max.: 80 °C

Material: Housing: Aluminium

Use: For gear flow meters HK VCA

Identification	Design	Weight kg
HK SD1 I 24	Output 0-20 mA / 4-20 mA	0,2
HK SD1 K 24	Output 2x relay contact 24VDC / 1A	0,2

HK SD1

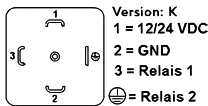
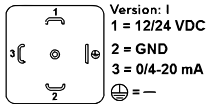

Web: <http://cat.hansa-flex.com/en/HKSD1>

Accessory for following products:

HK VCA - Gear flow meter

HK BFS 30

Flow switch

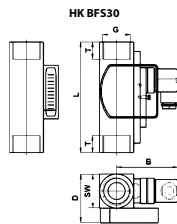

Flow switch for any mounting position for liquids from 30 up to 600 cSt.

Changeover contact (250 V / 1,5 A / 50 VA)

Protection class IP 65

Measuring accuracy $\pm 10\%$ of range limit value

Operating pressure: max. 250 bar

Operating temperature max.: 120 °C

Material: Brass

Note: To avoid the risk of measure faults, the upstream line should be 10x ND and the downstream line 5x ND. (ND = internal tube diameter)

Identification	Volumetric flow min.	Volumetric flow max.	B mm	D mm	G	L mm	T mm	AF mm	Weight kg
	L/min	L/min							
HK BFS30 010 030 G1 W	10,0	30,0	76	40	G 1"	130	17	40	1,25
HK BFS30 020 060 G1 W	20,0	60,0	76	40	G 1"	130	17	40	1,25
HK BFS30 035 110 G1 W	35,0	110,0	76	40	G 1"	130	17	40	1,25

Web: <http://cat.hansa-flex.com/en/HKBFS30>

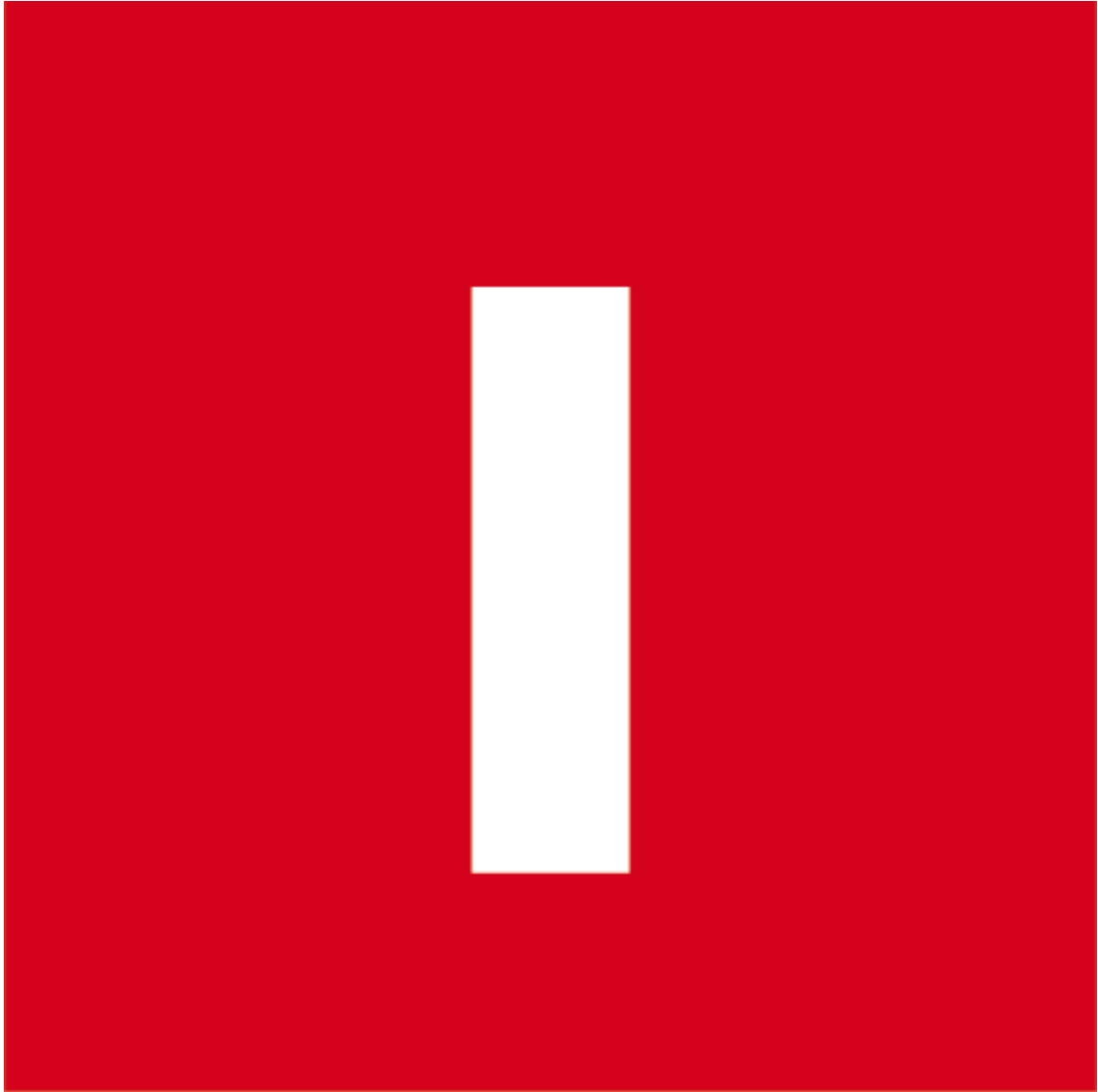

Subject Index / Index

2	
2-way ball valve, 700 bar, in block design	398
2-way directional control valve FD	140
2-way directional flow control valve PCFC	139
2-way pressure balance	208,220
2/2-way solenoid-controlled seat valve EMDV	142-143
2/2-way solenoid-operated directional control valve DTDA	144
3	
3/3-way changeover valve	260
3/2-way directional solenoid valve for pipeline installation	264
3-way flow control valve BFCV	141
3-way pressure reduction valve PRRS	134
4	
4/3-way changeover valve	261
6	
6/3-way changeover valve	262
6/2-way directional solenoid valve for pipeline installation	265
8	
8/3-way changeover valve	263
A	
Accumulator adapters for safety and isolation block	296
Accumulator clamp	297-298
Actuation for hand-operated directional control valve BM	272-273
Adapter and threaded connectors 700 bar	403
Adapter cables	256
Adapter for sample bottle	442
ADR non-return valve	111
ADRL non-return valve	112
Adsorbent silicagel	433
Adsorber filter reusable with valve	430-431
Adsorber filter single use without valve	429
Aluminium housing for SAE 2-way cartridge valve	145
Aluminium housing for SAE 3-way cartridge valve	146
Analogue Q gauge	458
Analogue QPT gauge	458
Analogue QPT-K gauge	459
Axial oil fitting	376
Axial, round oil fitting	376
B	
BAKRA hydraulic tank	303
Ball joint fitting	369
BEK hydraulic tank (without cleaning hatch)	306
Bellows for PAM manual pump	47
Bent axis axial piston pump	73
BFM adapter for MAP pressure switch	322
BHF AG adapter for MAP pressure switch	321
BHF IG adapter for MAP pressure switch	320
BHM mounting plate for MAP pressure switch	323
BKM mounting plate for MAP pressure switch	324
Bladder accumulator	291
Blind plugs	403
BMM adapter for MAP pressure switch	321
BMP HD CN geroller motor	93
BMR HD CN geroller motor	90
BMS CN geroller motor	86
BMT CN geroller motor	88
BSK hydraulic tank (with cleaning hatch)	307
Built-in heating with fixing magnets	316
Burst pipe protection IR	109
Burst pipe protection M	110
Bypass flow filter system Type C	448
Bypass flow filter system Type D	448
Bypass flow filter system Type E	449
C	
Cap for DC electric motors	351
Cap nut for solenoid-operated directional control valve	289
Castor for aluminium tank Type BAK RA	305
CFL flange	362-363
Check valve	205-206,217-218,224,227
Check valve SC, double-acting	115
Check valve SC, single-acting	115
Check valve SC, single-acting with venting	116
Chrome-plated piston rod	386
Chrome-plated piston rod CRNI	387
Chrome-plated piston rod HC 200	386
Chrome-plated piston rod HC 500	387
Clamping ring for plunger cylinder	384
Cleaning hatch cover for steel tank, Type BSK	309
Clogging indicator electrical	437-438
Clogging indicator mechanical	438
Clogging indicator pressure gauge	437
COF swivel bearing	362
Coil for cartridge valve EMDV	281
Coil for cartridge valve SUN	281
Coil for HK DG4V3 solenoid-operated valve	278
Coil for HK DG4V5 solenoid-operated valve	280
Coil for HK41C solenoid-operated valve	278
Coil for HKDH solenoid-operated valve	277
Coil for solenoid-operated directional control valve HK DFE	282
Coil for solenoid-operated directional control valve HK DKE	279
Coil for solenoid-operated directional control valve HK42C	280
Combination instrumentation cable	462
Connection plate for flow control valve QV	240
Console for bladder accumulators	298
Counter nut	128
Counterbalancing valve SC, double-acting	124
Counterbalancing valve SC, single-acting	125
Coupling hub	69
Couplings, dust protection 700 bar	404
Cover for glass sample bottle	441
Cover for plastic sample bottle	440
Cover panel NG10	236
Cover panel NG6	233
CPB swivel pin	368
Cylinder barrel	388
Cylinder base	370-373
Cylinder base with oil inlet	373
Cylinder base with outer thread	370
D	
Damping ring	339
DC 12V electric motor	350
DC 24V electric motor	350
DC 48V electric motor	351
Diaphragm accumulator, connection A	292
Diaphragm accumulator, connection C	293
Digital electronic driver HK EMI AS IR	258
Digital gauge set	463
Digital hand-held gauge, 5-channels	459
Directional control valve NG16	191
Directional control valve NG25	192
Directional control valve NG6, hydraulically controlled	195
Directional control valve NG6, pneumatically controlled	196
DLMDL damping rail	338
DRV 1700	106
DRV IR	107
DV IR	104
E	
Electric motor B3/B14 230/400V	347
Electric motor B3/B14 230/400V IE2	348
Electric motor B3/B14 230V	346
Electric motor B3/B14 400/690V IE2	349
Electric motor B3/B5 230/400V	340
Electric motor B3/B5 230/400V IE2	340
Electric motor B3/B5 400/690V IE2	342
Electric motor B3/B5 400/690V IE3	344
Electric motor B5 230/400V IE2	341
Electric motor B5 400/690V IE2	343
Electric motor B5 400/690V IE3	345
Electrical connector for proportional valves	284
Electrical plug for solenoid coil DIN 43650 / ISO 4400	283
Electro-hydraulic pumps 700 bar	391
Emergency hand operation for directional solenoid valve	289

EPM gerotor motor	92
EPMM gerotor motor	91
EPMS geroller motor	85
EPMT geroller motor	87
EPRM geroller motor	89

F	
FI BL 116	310
FI BL E MP	311
FI BL FP	310
FI BL GP	309
FI HD 400	420
FI HD E HY	425
FI HD E MA	424
FI HD E MP	424
FI HD GEH	421
FI MD 315	422
FI MD GEH	423
FI ND E AR	425
FI ND E HY	425
FI ND E MA	426
FI ND E MP	426
FI ND E PL	427
FI ND E SF	427
FI ND E ST	428
FI ND E UF	428
FI RL	409-410
FI RL E AR	413
FI RL E HY	414
FI RL E MP	413
FI RL GEH	411
FI RL RVL	414
FI SG E MP	408
FI SP E HE	418
FI SP E HY	419
FI SP E MA	419
FI SP E MP	418
FI SP E SO	419
FI SP R 1	415
FI SP R 2	415
FI SP R 3	416
FI SP R/S FK	417
Filter element for high-pressure filter HY	425
Filter element for high-pressure filter MA	424
Filter element for high-pressure filter MP	424
Filter element for low-pressure filter AR	425
Filter element for low-pressure filter HY	425
Filter element for low-pressure filter MA	426
Filter element for low-pressure filter MP	426
Filter element for low-pressure filter PL	427
Filter element for low-pressure filter SF	427
Filter element for low-pressure filter ST	428
Filter element for low-pressure filter UF	428
Filter element for oil service appliance HK FAPC 016	451
Filter element for return filter AR	413
Filter element for return filter HY	414
Filter element for return filter MP	413
Filter element for single use adsorber	432
Filter element for spin-on filter HE	418
Filter element for spin-on filter HY	419
Filter element for spin-on filter MA	419
Filter element for spin-on filter MP	418
Filter element for spin-on filter SO	419
Filter element for suction filter MP	408
Filter for vacuum filtration	447
Filter head for spin-on return flow filter / suction filter	417
FL swivel bearing	362
Flange for gerotor motor	97
Flat cylinders 700 bar single-acting with lock nut	394
Flat cylinders 700 bar single-acting with spring retraction	392-393
Flow control check valve	105,203-204,215-216,225,228
flow control valve	127
Flow control valve for plate mounting Cetop	239
Flow control valve with secondary pressure relief	127
Flow divider / combiner FDCV	137

Flow divider / combiner FS	138
Flow switch	466
Flow-control non-return valve V765Z	106
Fluid sampling set, dynamic	439
Fluid sampling set, static	439
Foot flange for pump mounts	337
Foot for aluminium tank Type BAK RA	305

G	
Gas valve kit for bladder accumulators	295
Gasket for hydraulic tank BAKRA	304
Gasket for pump mounts	339
Gear flow divider, size 1 9RD 2-way	75
Gear flow divider, size 1 9RD 4-way	78
Gear flow divider, size 1 9RS 2-way	76
Gear flow divider, size 1 9RS 4-way	79
Gear flow divider, size 1 9RV 2-way	77
Gear flow divider, size 1 9RV 4-way	80
Gear flow divider, size 2 92RD 2-way	81
Gear flow divider, size 2 92RD 4-way	83
Gear flow divider, size 2 92RV 2-way	82
Gear flow divider, size 2 92RV 4-way	84
Gear flow meter	465
Gear pump, size 0 ABBA	49
Gear pump, size 0 K0	50
Gear pump, size 1 CBD	56
Gear pump, size 1 FBBA	52
Gear pump, size 1 FIIA	53
Gear pump, size 1 GIIA	51
Gear pump, size 1 K1	54
Gear pump, size 1 K1 CON	55
Gear pump, size 2 CBTF	58
Gear pump, size 2 CSRA	63
Gear pump, size 2 EBBA / ECBA	60
Gear pump, size 2 EOOA / EPOA / EQPA	57
Gear pump, size 2 FSRA	61,64-65
Gear pump, size 2 ISRA	62
Gear pump, size 2, low noise	59
Gear pump, size 3 CBD1F5	67
Gear pump, size 3 X3P	66
GGG40 housing for SAE 2-way cartridge valve	148
GGG40 housing for SAE 3-way cartridge valve	149
Glass sample bottle	441
Glass vacuum filtration device	445
Glycerine pressure gauge up to 1000 bar	401
Guide housing for double-acting hydraulic cylinders 200 bar	377-378
Guide housing for double-acting hydraulic cylinders 250 bar	378-379
Guide housing for single-acting hydraulic cylinders 200 bar	377
Guide ring for inserted piston PF	385

H	
Hand lever & accessories for hand-operated directl. control valve	
BM	272
Hand pump 700 bar	390
Hand wheel for cartridge valve SUN	290
Hand-operated directional control valve BM 150	271
Hand-operated directional control valve BM 40	266-267
Hand-operated directional control valve BM 70	268-269
Hand-operated directional control valve BM 70 with high-speed function	270
Hand-operated directional control valve NG10	169-170
Hand-operated directional control valve NG6	166-168
HDS pressure switches	318
HFM MMD HKO	462
High pressure filter 400bar	420-421,423
High speed/creep speed unit for flow control valve QV	241
Hinged cylinder base with oil inlet	374
HK 054 2	124
HK 054 322	125
HK 055 211	115
HK 055 283	116
HK 055 3	115
HK 0P ABBA	49
HK 1P FBBA	52
HK 1P FIIA	53
HK 1P GIIA	51

HK 2P 1 FSRA	64	HK BM KOL	274
HK 2P 2 FSRA	65	HK BM MS	275
HK 2P 4 FSRA	61	HK BM150	271
HK 2P CSRA	63	HK BM40	266-267
HK 2P ExBA	60	HK BM70	268-269
HK 2P ExxA	57	HK BM70 AUTO	270
HK 2P ISRA	62	HK BMM	321
HK 41 C1	168	HK BSK	307
HK 41 C1 (7/G/Q/R)	178-180	HK BSK RD	309
HK 42 C1 (7/G/Q/R)	188-190	HK CA	383
HK 622	460	HK CAGE	368
HK 64EJ	325	HK CAGEN	367
HK 92RD 02 BG2	81	HK CAT	384
HK 92RD 04 BG2	83	HK CB	361
HK 92RV 02 BG2	82	HK CB L	136
HK 92RV 04 BG2	84	HK CBD ZLBA	56
HK 9RD 02 BG1	75	HK CBD1 F5	67
HK 9RD 04 BG1	78	HK CBF	361
HK 9RS 02 BG1	76	HK CBS	375
HK 9RS 04 BG1	79	HK CBSLT	376
HK 9RV 02 BG1	77	HK CBSP	375
HK 9RV 04 BG1	80	HK CBSS	375
HK ADR	111	HK CBTF	58
HK ADRL	112	HK CD	298
HK AGRL	243	HK CDA	389
HK AQFR	107	HK CDB	389
HK ARAM	102	HK CE	297
HK ARE	101	HK CF	372
HK AS	296	HK CF (AG)	370
HK ASEP	389	HK CF 00	370
HK AX RU	376	HK CFB	374
HK AXIAL	376	HK CFE	373
HK AZ11	403	HK CFF	364
HK AZ16	402	HK CFHR	371
HK AZ51	398	HK CFHR2	372
HK AZ52 DRV	399	HK CFHRT	373
HK AZ55 RV	399	HK CFL	362-363
HK B3/B14 230/400V	347	HK CFP	363
HK B3/B14 230/400V IE2	348	HK CFPM	371
HK B3/B14 230V	346	HK CFS	363
HK B3/B14 400/690V IE2	349	HK CFVP	373
HK B3/B5 230/400V	340	HK CG	377-378
HK B3/B5 230/400V IE2	340	HK CGE	367
HK B3/B5 400/690V IE2	342	HK CGPM / CG30	378-379
HK B3/B5 400/690V IE3	344	HK CGT	377
HK B5 230/400V IE2	341	HK CK XCN	135
HK B5 400/690V IE2	343	HK COF	362
HK B5 400/690V IE3	345	HK CPB	368
HK BA 11 NG10 NG6	236	HK CSB	369
HK BA 20 NG6	229	HK CSR	364
HK BA 210	209	HK CSR 104	364
HK BA 214 NG6	230	HK CSTS C	365
HK BA 3/4 NG10	234	HK CSTS N	365
HK BA 310	221	HK CT	382
HK BA 314 NG10	234	HK CT11	382
HK BA 4/5 NG16	237	HK CTB	383
HK BA 6 NG25	238	HK CTBF	381
HK BA AGRL	244	HK CTF	380
HK BA QV	242	HK CTLM	383
HK BAK RA	303	HK CTPM	381
HK BEK	306	HK DB MOS	308
HK BF	69	HK DBV R	400
HK BFCV	141	HK DFE 3	264
HK BFM	322	HK DFE 6	265
HK BFS 30	466	HK DG4V3	175-177
HK BHF AG	321	HK DG4V5	185-187
HK BHF IG	320	HK DH01	166-167
HK BHM	323	HK DH04/05	195
HK BHQ	240	HK DH08/09	196
HK BKM	324	HK DHA	197
HK BLAK	291	HK DHE X 00 AC	173-174
HK BLAK REPKIT	294	HK DHE X 00 DC	171-172
HK BM BET	272-273	HK DHQ	241
HK BM C0	275	HK DHZO A	247
HK BM HEB	272	HK DK11	169-170

HK DKE X 00 AC	183-184	HK GEH EC	155
HK DKE X 00 DC	181-182	HK GEH FA	156
HK DKZOR A	249	HK GEH GA	157
HK DLHZO TE	248	HK GEH GBA	163
HK DLKZOR TE	250	HK GEH GBY	164
HK DLMDL	338	HK GEH MBJ	165
HK DLO	193	HK GEH MM	158
HK DPH 2	191	HK GEH RK RB AG IG	122
HK DPH 4	192	HK GEH RK RB IG	123
HK DPT	339	HK GEH YA	159
HK DRH	117	HK GEH YE	160
HK DRV	339	HK GEH ZP NG	150
HK DS 100	461	HK GEH ZP NG10 KH	222
HK DSR	319	HK GEH ZP NG6 KH	210
HK DSR 4POL	324	HK GEH ZP16 DB ST	151
HK DTDA	144	HK GEH ZP25 DB ST	151
HK E SW	259	HK GK	380
HK EA EC	256	HK GP	339
HK EBM AS	257	HK GR33	59
HK EC PC IR USB	259	HK HAM / HAE	391
HK ECM	397	HK HC 01	208
HK EH 1460	316	HK HDS	318
HK EM 207 NG16	237	HK HFR	353
HK EM 208 NG25	238	HK HFR25	354-355
HK EMDV	142-143	HK HFRT	356
HK EMI	258	HK HG 03	201
HK EP DS	96	HK HL / PL	336
HK EPM CD	92	HK HM	357-359
HK EPMM C	91	HK HM 01	198
HK EPMM F	97	HK HM BM DS	96
HK EPMS	85	HK HM BMP HD	93
HK EPMT	87	HK HM BMR HD	90
HK EPRM CD	89	HK HM BMS	86
HK ES3 NG6	232	HK HM BMT	88
HK ES5 NG10	235	HK HMP 01	199
HK FAC	386	HK HQ 01/02	203
HK FAC CRNI	387	HK HR 01	205
HK FAC HC2	386	HK HR SUN	290
HK FAC HC5	387	HK HS 01	209
HK FAPC	450	HK HT	360
HK FAPC 1760	451	HK HV 700	403
HK FAPC F	451	HK HV RK	398
HK FCCV HF	105	HK HZGO A 031	251
HK FCV HN	103	HK HZMO A 030	252
HK FD	140	HK ICM	444
HK FDCV	137	HK ICM USB	445
HK FES DMM	439	HK JPQ2	225
HK FES SUP	439	HK JPQ3	228
HK FI AD E0/EV	429	HK JPR2	224
HK FI AD ET	432	HK JPR3	227
HK FI AD ETS	433	HK K C E-Motor 12V	350
HK FI AD FS	434	HK K C E-Motor 24V	350
HK FI AD FS BY	436	HK K C E-Motor 48V	351
HK FI AD FS FILL	435	HK K CAP	351
HK FI AD MV	430	HK K REL	352
HK FI AD MV VARIO PA	431	HK K0	50
HK FI AD SK	433	HK K1	54
HK FL	362	HK K1 CON	55
HK FPMD	126	HK KC 01	220
HK FR	385	HK KG 03	213
HK FS	138	HK KL EJ	332
HK FT	388	HK KM 01	211
HK FT 290	276	HK KM 202	128
HK FT 291	276	HK KONS	298
HK FUSS BAK RA	305	HK KPL 700BAR	404
HK GEH 20 AL	145	HK KQ 01/02	215
HK GEH 20 GGG	148	HK KR 01	217
HK GEH 30 AL	146	HK KS 01	221
HK GEH 30 GGG	149	HK KS33	463
HK GEH 40 AL	147	HK KZGO A 031	253
HK GEH BC	152	HK LBS TOOL	129
HK GEH CA	153	HK LBS TOOL RK	130
HK GEH DA	154	HK LCPG	315
HK GEH EBA	161	HK LK EJ	326
HK GEH EBY	162	HK LR BAK RA	305

HK LVA	313	HK RZGO A 033	255
HK LVK	314	HK RZGO AE 033	255
HK M HK 41 C	287	HK RZMO A 010	254
HK M HK 42 C	287	HK RZMO A 030	254
HK M HK AGRL	288	HK RZMO AE 030	253
HK M HK DH	285	HK S	458
HK M HK DK	285	HK S TK	458
HK M HK DPH 2	286	HK S TKV	459
HK M HK DPH 4	286	HK SAB M	296
HK M HK QV	288	HK SD1	466
HK M HK V0590	95	HK SH	395
HK MA	401	HK SM	396
HK MAP	317	HK SMP	393
HK MD	401	HK SMX	392
HK MH 2025	463	HK SP 41C	278
HK ML32	70	HK SP 42C	280
HK ML52	70	HK SP 6 DLOH	194
HK MRSL NG6	231	HK SP 770	281
HK MSM	297	HK SP CAE	279
HK NTM	327	HK SP CO	277
HK NTM XP	328	HK SP DFE	282
HK OEW BAK	305	HK SP DG4V3	278
HK OEW BSK	308	HK SP DG4V5	280
HK OILAIR 2000	300	HK SP DIN 43650	283
HK OILAIR HPA	301	HK SP EMDV	281
HK OLM A	292	HK SP WPD / SP SET / 6 OE	289
HK OLM C	293	HK SP10 BA NG10	236
HK PAM 014 R	44	HK SP6 BA NG6	233
HK PAM 014 T	45	HK SPIDEX Z	334
HK PAM 015 T	46	HK SPZ	284
HK PAM Faltenbalg	47	HK ST BAK RA	304
HK PAM Hebel	47	HK STX	394
HK PAN	329	HK SU 2	68
HK PAN M	329	HK SU 3	69
HK PART	443	HK TE	397
HK PBA	73	HK TEHM	316
HK PCFC	139	HK THERMO EJ	333
HK PF	384	HK TKO / TKS	332
HK PFE	74	HK TKT G	312
HK PG24	320	HK TLA	315
HK PK	336	HK TM 4	302
HK PM0 022	48	HK TS	330
HK PML	462	HK TS TP	461
HK PN2070	318	HK TSD G	312
HK PQT	462	HK TSF	311
HK PROBEF ADA AL	442	HK TSK1	331
HK PROBEF GL	441	HK UEB MUT	289
HK PROBEF GL DEK	441	HK V0 12	98
HK PROBEF LDPE	440	HK V0 590	94
HK PROBEF LDPE DEK	440	HK V1 501	111
HK PRRS	134	HK V1 601	108
HK PT	335	HK V1 710	112
HK PT2020	464	HK V1 865	113
HK PT77	319	HK V1 866	113
HK PTA	460	HK V2 190	123
HK PTF	337	HK V2 290	124
HK PTQ CHECK	459	HK V2 572	103
HK PVPC	71	HK V2 575	105
HK PVPC CONTROL	72	HK V2 765 Z	106
HK QV	239	HK V6 215	127
HK RB	122	HK V6 215 DBV	127
HK RB F	120	HK V7 367	260
HK RD	132	HK V7 467	261
HK REM	245	HK V7 667	262
HK REM 24	246	HK V7 867	263
HK RH	118	HK VA EL	437
HK RK	121	HK VA MAN	437
HK RK E	119	HK VA PIS EL	438
HK ROTEX AF	335	HK VA PIS M	438
HK ROTEX Z	334	HK VAK FILTRA GL	445
HK RP	133	HK VAK MEM	447
HK RS BAK RA	304	HK VAK PUMPE	440
HK RTR	412	HK VCA	465
HK RV063	109	HK VGU	299
HK RVPS	131	HK VGU GAS VENT	295

HK VML	95
HK VMP BL	99
HK VMP BL F	128
HK VMPP BL	100
HK VRDE	114
HK W / HK X	390
HK WAPR	366
HK X3P ABAA/ACBA	66
HK Z PNEU	391
HK ZDR 01	202
HK ZDR 02	214
HK ZDV 01	200
HK ZDV 02	212
HK ZK	338
HK ZNS 01	207
HK ZNS 02	219
HK ZP 16 DB	223
HK ZP 25 DB	226
HK ZRD 01	204
HK ZRD 02	216
HK ZRV 01 / ZRE 01	206
HK ZRV 02 / ZRE 02	218
HL / PL pump mount	336
Hollow piston cylinder 700 bar	395
Housing for flow divider SAE 3-way aluminium	147
Housing for non return valve RK/RB	122-123
Housing for return flow filter	411
Housing sandwich plate for cartridge valve T-31A	165
Housing sandwich plate with measurement connctn. for cart. valve T-11A	161-162
Housing sandwich plate with measurement connctn. for cart. valve T-13A	163-164
Hydraulic oil, synthetic (Panolin)	452

I	
Inline Contamination Monitor	444
Inserted piston for hydraulic cylinders	382-383
Inserted piston with plunger cylinder guide	384
Inserted piston without plunger cylinder guide	383

L	
Level contact for level/temperature switch	326
Level/temperature switch HK 64EJ	325
Level/temperature switch HK NTM	327
Level/temperature switch HK PAN	329
Level/temperature switch with LED display HK NTMXP	328
Lever for PAM manual pump	47
Line break safety valve without housing	108
Lock nuts for diaphragm accumulator C	297
Long oil fitting	375

M	
M12 4-pin angle plug with cable	324
M12 8-pin plug with cable	329
Manifolds 700 bar	402
Manual pump for pipeline installation	44
Manual pump for tank installation	45
Manual pump for tank installation with directional control valve	46
MAP pressure switch	317
Measuring connection, M16 x 2 series	462
Measuring turbine	460
Medium pressure filter 315 bar	422
Microswitch for hand-operated directional control valve BM	275
Mineral oil-based engine oil	453
Mineral oil-based hydraulic oil	452
Mounting flange for adsorber	434-436
Mounting plate for flow control valve QV	242
Mounting plate for non-return valve AGRL	244

N	
Needle shut-off valve 700 bar	398
Non return valve RB	117-118,122
Non return valve RK	121
Non return valve with housing type E	119
Non return valve with housing type F	120

Non-return valve 700 bar	399
Non-return valve CK	135
Non-return valve for plate mounting Cetop P	243
NSFA Typ C	448
NSFA Typ D	448
NSFA Typ E	449

O	
OEL ATF	453
OEL BIND	454
OEL HLP	452
OEL HLPD 46	452
OEL MATTE	454
OEL PANOLIN	452
OEL SYNT	453
OEL W	453
OELANALYSE SET 2	446
OELANALYSE SET 3	446
OELANALYSE SET 4	447
Oil analysis set for bio oil	446
Oil analysis set for gear oil	447
Oil analysis set for mineral oil	446
Oil binding agent, (granular)	454
Oil binding agent, (matt)	454
Oil fitting	375
Oil fitting for pipe connection	376
Oil fitting with bleeding	375
Oil service appliance	450
Oil sight glass	315
Oil tray for alu tank, Type BAK	305
Oil tray for steel tank, Type BSK	308
Oil/air coolers	301
Oil-air cooler	300
Optical/electrical fill level indicator with temperature switch	314
Overcentre valve	207,219
Overcentre valve CB	136

P	
Particle counter	443
Piston for hand-operated directional control valve BM	274
Piston protection nut, self-locking	389
Piston protection nut, self-locking, flat-headed	389
Pivot yoke	364
Pivot yoke with regreasable bearings	365-366
Plastic sample bottle	440
Plug-in display digital	466
Plug-in non-return valve	194
Pneumo-hydraulic pump 700 bar	391
Poppet valve NG6	193
Pressure gauge adapter 700 bar	401
Pressure gauge shut-off valve FT290	276
Pressure gauge shut-off valve FT291	276
Pressure reduction valve	201-202,213-214
Pressure relief valve	198-200,211-212,223,226
Pressure relief valve 700 bar	400
Pressure relief valve ARAM	102
Pressure relief valve ARE	101
Pressure relief valve FPMD (shock valve)	126
Pressure relief valve RD	132
Pressure relief valve RP	133
Pressure relief valve RVPS	131
Pressure relief valve V012	98
Pressure relief valve with SAE connection and relief valve	246
Pressure relief valve with SAE connector	245
Pressure sensor	460,464
Pressure sensor controller DSR	319
Pressure sensor controller PN2070	318
Pressure sensor regulator PT77	319
Pressure sensor with analogue and digital display	320
Pressure sequence valve	209,221
Pressure transmission for hand-operated directional control valve BM	275
Proportional amplifier digital	257
Proportional pressure reducing valve size 10	253
Proportional pressure reducing valve size 6	251,255

Proportional pressure relief valve size 6	252-254
Proportional solenoid-operated directional control valve size 10	249-250
Proportional solenoid-operated directional control valve size 6	247-248
Protective case for measuring instrument	463
PTO shaft gearboxes	70
Pump carrier PK	336
Pump mount PT	335
Pump supports	68-69
PVPC axial piston pump	71

R	
Radial pivot bearings GE	367
RBS IR	109
RBS M	110
Reducer plate NG10 - NG6	236
Refill-kit for reusable adsorber	433
Regulating check valve 700 bar	399
Regulating check valve DRV IR	107
Regulating check valve DVR 1700	106
Repair kit for bladder accumulator	294
Resistance thermometer for level/temperature switch	332
Return flow filter compact tank installation	412
Return flow filters	409-410
Ring for pivot bearing	367-368
Rotex coupling for axial piston and vane pumps	335
Rotex coupling for gear pumps	334
Rubber-metallic buffer	339

S	
Safety and isolation block with manual relief	296
Sandwich body with measurement connection	209,221
Screw kit for non-return valve Type HK AGRL	288
Screw kit for shock valve HK V0590	95
Screw set for flow control valve Type HK QV	288
Screw set for NG 6 valves type HK DH / DG4V3	285
Screw-in tubular heaters	316
Seal kit for hydraulic planetary motor	96
Seal kit for hydraulic planetary motor CN	96
Sealing cap	312
Sealing cap / oil dipstick	312
Sealing tape for tanks	308
Serial connection plate NG10	234
Serial connection plate NG16	237
Serial connection plate NG25	238
Serial connection plate NG6	230
Set of bolts for NG 10 valves types HK DK11/DKE/DG4V5	285
Set of bolts for NG10 valves type HK 42 C	287
Set of bolts for NG16 valves type HK DPH 2	286
Set of bolts for NG25 valves type HK DPH 4	286
Set of bolts for NG6 valves type HK 41C	287
Shock valve	94
Short inserted piston for hydraulic cylinders	383
Short threaded piston for hydraulic cylinders	381
Single connection plate NG10	234
Single connection plate NG16	237
Single connection plate NG25	238
Single connection plate NG6	229,231
Single connection plate with relief valve size 10	235
Single connection plate with relief valve size 6	232
Single instrumentation cable	462
Software for ATOS proportional electronics	259
Solenoid-operated directional control valve NG10	185-190
Solenoid-operated directional control valve NG6	175-180
Solenoid-operated directional control valve size 6 without coil	171-174
Solenoid-operated directional control valve size 6, Ex-protected	197
Solenoid-operated directional control valve size 10 without coil	181-184
Speed sensor	461
Spidex coupling for gear pumps	334
Spin-on return flow filter type 1	415
Spin-on return flow filter type 2	415
Spin-on return flow filter type 3	416
Spring for shock valve	95
Spring for VMPBL pressure relief valve	128
Sprocket for coupling	338

Standard double-acting cylinders with fastening	353-355
Standard double-acting cylinders without fastening	357-359
Standard single-acting cylinders with fastening	356
Standard single-acting cylinders without fastening	360
Start relay for DC electric motor	352
Steel cap for hydraulic tank BAKRA	304
Steel housing sandwich plate NG6/10 for SAE 2-way cartridge valve	150
Steel housing ZP NG16 for SAE 2-way pressure relief valve	151
Steel housing ZP NG25 for SAE 2-way pressure relief valve	151
Swivel bearing bushing	361
Swivel bearing bushing with bore	361
Synthetic ester-based hydraulic oil	453

T	
Tank for PAM manual pump	48
Tank venting and filler filters	310
Tank venting filters	309-311
Temperature contact for level/temperature switch	332
Temperature sensor	461
Temperature transmitter for level/temperature switch	333
Thermostat for oil/air cooler	302
Threaded piston for hydraulic cylinders	380-382
Throttle check valve AQFR	107
Throttle valve	103
Throttle valve DV IR	104
Tool for line break safety valves	129-130
Traction cylinders 700 bar	397
Transmission and hydraulic oil	453
TS temperature switch	330
TSK1 temperature switch	331
Tube extension for return flow filter	414

U	
Unit carrier	451
Universal cylinders 700 bar single-acting with spring retraction	396
USB adapter	445
USB infrared adapter	259

V	
V1501 non-return valve	111
V1710 non-return valve	112
V1865 non-return valve	113
V1866 non-return valve	113
V2190 lowering valve	123
V2290 lowering valve	124
Vacuum hand pump	440
Valve housing for cartridge valve T-10A	156
Valve housing for cartridge valve T-11A	155,160
Valve housing for cartridge valve T-13A	157
Valve housing for cartridge valve T-2A	152,159
Valve housing for cartridge valve T-31A	158
Valve housing for cartridge valve T-3A	153
Valve housing for cartridge valve T-5A	154
Valve housing for line break safety valve	109
Valve housing ZP NG10 with ball valve	222
Valve housing ZP NG6 with ball valve	210
Vane pump	74
Vent screws	389
Venting filter element	311
Venting valve unit	72
VGU tester and charging unit	299
Visual fill level indicator	313
VMP BL pressure relief valve	99
VMPP BL pilot-controlled pressure relief valve	100
VRDE non-return valve for cylinder installation	114

W	
Workbench press 700 bar	397

Y	
Yoke end with thread	364
Yoke end, long	363
Yoke end, short	363



**Catalogue 1:
Hose Technology**

Hoses	
Hose fittings	
Couplings	
Measuring equipment	



**Catalogue 2:
Connection Technology**

Pipe fittings ISO 8434-1	Mounting technology
Pipes	Accessories and tools
Adapters	
Flanges	
Ball valves	
Measuring equipment	



**Catalogue 3:
Industrial Technology**

Hoses	Compressed air technology
Hose fittings	Fluid service
Couplings	Accessories and tools
Ball valves	
Mounting technology	
Water technology	



Pneumatic Products

Hoses and accessories	Cylinders and control valves
Hose couplings	Service units
Screw fittings and connectors	linear drive technology
Pipeline system Infinity	Vacuum technology
Pressure and temperature measurement	
Valves and shut-off devices	



Metal Hoses

Metal hoses	Hose fittings
PTFE hoses	
Wound hoses	
Coolant hoses	
Expansion joints	
Hose protection	



Sealing technology

Hydraulic seals	Moulded parts
Pneumatic seals	
Seal kits and measuring equipment	
Static seals	
Flat seals	
Sealing rings	

